

# Evaluation Report

# 711

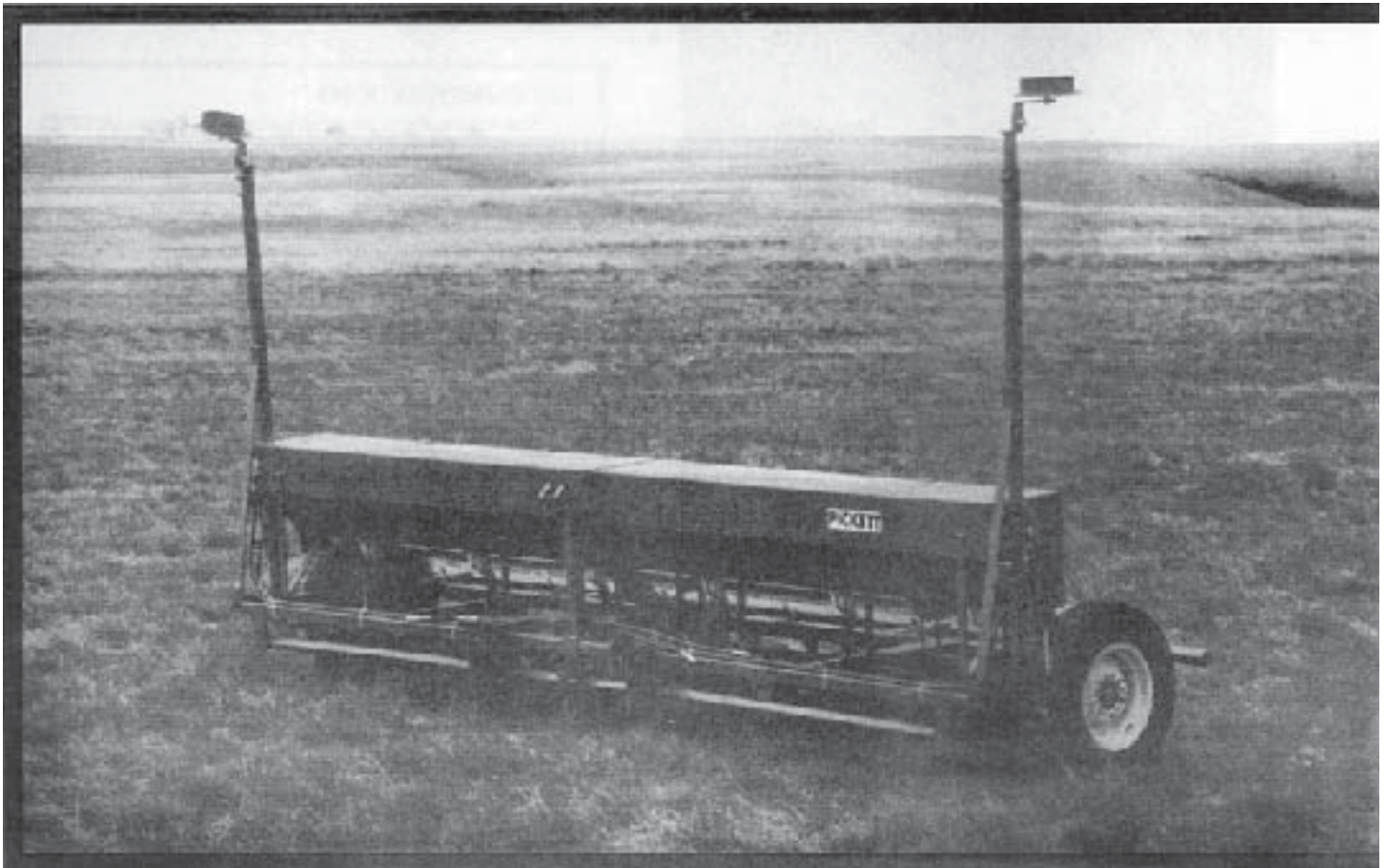

## Pickett Bean Planter

A Co-operative Program Between



# PICKETT BEAN PLANTER

## MANUFACTURER AND DISTRIBUTOR

Pickett Equipment  
976 East Main  
Burley, Idaho  
USA 83318  
Phone: (208) 678-8260

## RETAIL PRICE:

\$11,352;00 (March, 1994 f.o.b. Lethbridge, Alberta)

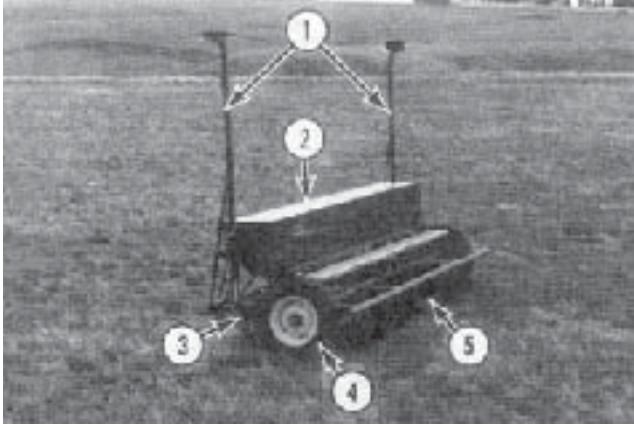

**FIGURE 1.** Pickett Bean Planter: (1) Row Markers, (2) Seed Box, (3) Double-Disc Openers, (4) Gauge Wheels and (5) Double-Covering Discs.

## SUMMARY

### QUALITY OF WORK

Penetration of the Pickett bean planter was very good in a wide variety of field conditions, providing the double-disc openers were properly adjusted and adequate pre-seeding tillage had been performed.

Seed placement was good. Variation in seed depth was small when seeding in tilled soils.

Soil finishing of the planter was good. A set of double-covering discs closed the seed furrow and formed a hill of loose soil over the seed.

The quality of the marking system was very good. The mark was visible from the tractor cab.

Operation of the Pickett in Stony conditions was fair. The trip clearance of the double-covering disc assemblies was inadequate to clear large stones.

Metering accuracy of the Pickett bean planter was good. Plant misses in the field were attributed to the seed bridging over a meter.

Uniformity of distribution of the application rate across the width of the planter was good. Uniformity of the inter-row seed spacing was unsatisfactory for precision seeders.

Seed handling was very good. Seed damage by the metering system was negligible.

### EASE OF OPERATION AND ADJUSTMENT

Ease of performing routine maintenance was very good.

Five minutes was required to lubricate the 10 grease fittings.

Ease of filling and cleaning the planter was fair. The box lids could not be locked in the open or closed positions.

Ease of hitching to the planter was good. A centre support stand allowed for safe unhitching of the unit.

Ease of transporting the planter was very good. Caution had to be taken when transporting because of the width, height and the weight of the unit.

Ease of operating and adjusting the marking system was very good.

Monitoring was unsatisfactory on the planter. No acre meter, metering shaft motion indicator or seed flow sensors on the meters were provided.

Ease of changing the seeding rates was poor. No calibration charts were provided. Adjusting seeding rates was inconvenient.

Ease of setting the seed depth adjustment was fair. Two people required 15 minutes to adjust the depth.

## POWER REQUIREMENTS

A 76 PTO hp (57 PTO kW) tractor (with tire ballasts and weights) had sufficient power and hydraulic lift capacity to operate the Pickett bean planter and provide necessary stability.

## OPERATOR SAFETY

The Pickett bean planter was safe to operate if normal safety precautions were observed. A slow moving vehicle sign was not provided with the planter.

## OPERATOR'S MANUAL

An operator's manual was not provided with the test unit.

## MECHANICAL HISTORY

Numerous fasteners were tightened on the planter throughout the test. Both row marker extensions failed and had to be repaired during the test.

## RECOMMENDATIONS

The Alberta Farm Machinery Research Centre (AFMRC) recommends the manufacturer:

1. Offer row packers as optional equipment.
2. Modify agitation bar to prevent seed bridging over the meters.
3. Modify tank lids so they can be locked in the open and closed positions.
4. Modify planter's lower hitch linkage to use standard 1.13 in (29 mm) pins in accordance with the ASAE standard S217.1.
5. Offer an acre meter, seed flow sensors and a metering shaft motion indicator as standard equipment.
6. Modify metering shaft adjustment rod for easier seed rate adjustment.
7. Supply a slow moving vehicle sign as standard equipment.
8. Provide an operating manual with the planter.
9. Review all bolted assemblies on the planter.
10. Install flow restrictors in the row marker's hydraulic lines for slower operation.

Manager: R.P. Atkins, P.Eng.

Project Engineer: R.C. Maze, P.Eng.

Engineering Technician: A.S. Pickard

## MANUFACTURER'S REPLIES

The manufacturer states that with regards to recommendation number:

1. Yes, they are already an option but with the marker support assembly part of the machine.
2. Add length and narrowness to agitation arm.
3. Make lids so they spring to open position and stay. Using a reliable lock to hold lids in closed position.
4. We use step down pins so we can go to category II or III or category I to II with bushings on smaller step down pin.
5. Yes, we feel the added cost for the sensors would make the machine more complete and up-to-date. (These would be an option).
6. Location of the adjustment would be relocated more to the outside and above the tire and easier to get to.
7. Yes, we should put slow moving vehicle signs on the planter.
8. Yes, an operation manual should be with planter.
9. Maintain bolts or all fasteners every 6 to 8 hours of operation.
10. Three-eighths flow restrictor should be placed in the line.

## GENERAL DESCRIPTION

The Pickett bean planter is a Category II three-point hitch, row crop seeding unit designed for seeding in secondary tillage soil conditions. However, the Pickett is not classified as a precision seeder. The planter consists of a seed box mounted above a row of double-disc openers. A diamond shaped tool bar at the rear of the planter allows for mounting additional attachments. The six-row unit is designed to seed beans on a 30 in (762 mm) spacing but can seed other row crops.

Seed is metered by internal fluted feed rollers as shown in FIGURE 2. The meters are ground driven by the gauge wheels through a series of chains and sprockets. A flexible rubber hose

delivers seed to the opener assembly. Seed rate is adjusted by varying the exposed length of the metering feed roll in the seed cup. The metering shaft speed can be varied by using a combination of drive sprockets.

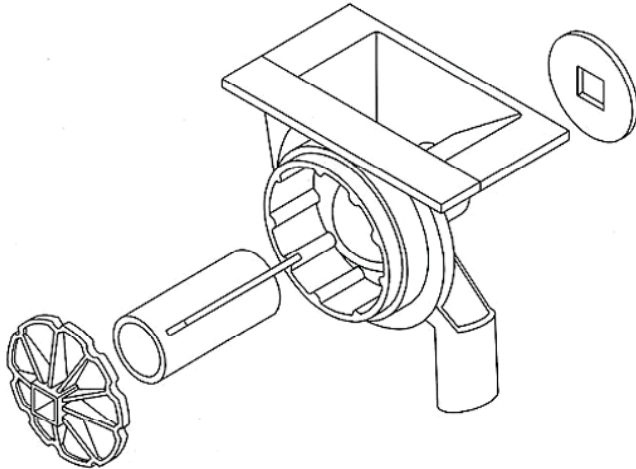

FIGURE 2. Internal Fluted Seed Metering Cup.

The Pickett bean planter is equipped with double-covering discs, which cover the seed with a loose hill of soil. Seed depth is controlled by adjusting the depth clips on the pressure rods. The force on the openers is controlled by varying the length of the pressure springs.

The test unit was 15 ft (4.6 m) wide with two hydraulic row markers. FIGURE 1 shows the location of the major components. Detailed specifications are given in APPENDIX I.

### SCOPE OF TEST

The Pickett bean planter was operated in the secondary tillage conditions shown in TABLE 1 for 68 hours while seeding 435 ac (174 ha). The unit was evaluated for quality of work, ease of operation and adjustment, power requirements, operator safety and suitability of the operator's manual. Seed metering systems were calibrated in the laboratory.

The machine evaluated by Alberta Farm Machinery Research Centre (AFMRC) was configured as described in the General Description, FIGURE 1, and the Specifications section of this report. The manufacturer may have built different configurations of this machine before and after AFMRC tests. When using this report, check that the machine under consideration is the same as the one reported here. If differences exist assistance can be obtained from AFMRC or the manufacturer to determine changes in performance.

TABLE 1. Operating conditions while seeding Pinto beans

| Soil Type  | Stone Conditions  | Field Area |     | Hours |
|------------|-------------------|------------|-----|-------|
|            |                   | ac         | ha  |       |
| Sandy Loam | Moderately Stony  | 140        | 56  | 20    |
|            | Stone Free        | 70         | 28  | 13    |
| Silt Loam  | Moderately Stony  | 65         | 26  | 10    |
|            | Occasional Stones | 15         | 6   | 3     |
| Clay Loam  | Moderately Stony  | 145        | 58  | 22    |
| Total      |                   | 435        | 174 | 68    |

## RESULTS AND DISCUSSION

### QUALITY OF WORK

**Penetration:** Penetration of the double-disc openers (FIGURE 3) was very good in a wide variety of field conditions, providing the openers were properly adjusted and adequate pre-seeding tillage had been preformed. Uniform penetration across the width of the planter required proper levelling of the drill.

Force on the openers varied by changing the length of the pressure springs. Six spring settings were possible. The maximum vertical force of the double-disc openers was 147 lb (654 N).

**Seed Placement:** Seed placement of the Pickett bean planter was good. Seeds were placed in furrows created by the double-disc openers.

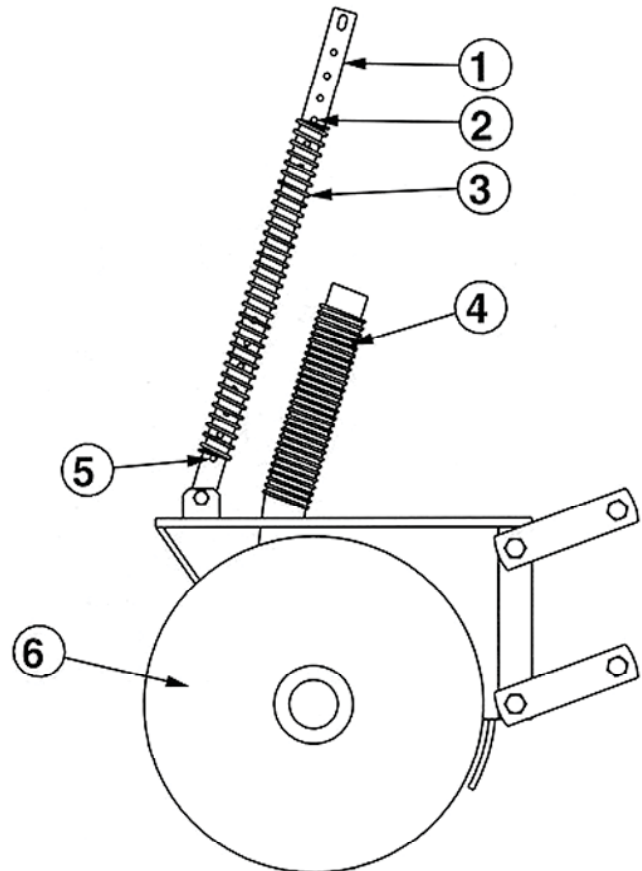

FIGURE 3. Double-Disc Opener: (1) Pressure Rod, (2) Depth Adjusting Clip, (3) Pressure Spring, (4) Seed Tube, (5) Pressure Adjusting Clip and (6) Discs.

Variation in seed depth was small when seeding in tilled soils. The gauge wheels provided consistent depth control. Most seeds were placed within 0.65 in (17 mm) of the average seed depth of 3.1 in (79 mm).

The deep seed depth was caused by the soil finishing of the drill.

**Soil Finishing:** Soil finishing of the planter was good. A set of double-covering discs closed the seed furrow and formed a hill of loose soil over the seed as shown in FIGURE 4. The discs could be adjusted to vary the size of the row hill. On the test unit the double-covering discs were set at 6.5 in (165 mm) apart. Average row hill height was 4 in (102 mm). Vertical force of the closing discs was varied by adjusting the spring tension. The seedbed was not packed. No information was provided about proper adjustment of the double-covering discs for optimum seed coverage.



FIGURE 4. Double-Covering Discs.

The hill of loose soil placed over the seed resulted in deeper seed placement. Due to a wet growing season there was poor seed emergence as shown in FIGURE 5. Soil moisture at the time of seeding was good so packers would have been adequate to firm the seedbed for better seed emergence. The double-covering discs may have performed better in drier growing conditions. The manufacturer should clarify the soil conditions the double-covering discs should be

used in to receive good seed emergence. The AFMRC recommends the manufacturer offer row packers as optional equipment.



FIGURE 5. Seed Emergence of a Field of Pinto Beans.

**Marking System:** The quality of the marking system was very good. FIGURE 6 shows the mark left by the marking system in tilled field conditions. The mark was visible from the tractor cab due to the difference in colour of moist and dry soil. Disc depth was controlled with a depth band. Disc angle was adjustable.



FIGURE 6. Row Marker.

**Stone Conditions:** Operation of the Pickett in stony conditions was fair. The 8 in (203 mm) lift of the double-disc openers were adequate to clear large stones. The trip clearance of the double-covering discs assembly of 4.4 in (111 mm) was inadequate to clear large stones. One covering disc was damaged and another disc had to be replaced. The cross bar on the double-covering disc assembly was bent on each set of double-closing discs.

**Metering Accuracy:** Metering accuracy of the Pickett bean planter was good. The seed metering rate was varied by lateral movement of the feed rolls and the shaft speed.

The planter's meters were zeroed before doing calibration tests. Seed calibration charts were not provided for the test unit. The calibration curves obtained by AFMRC for the Pickett bean planter in Pinto beans, corn, and Radley peas are given in FIGURE 7.

Operating the Pickett bean planter on a right slope of up to 15° decreased the metering rate by an average of 16%. Increasing the metering speed from 2.5 to 7.5 mph (4 to 12 km/h) decreased the metering rate by 5.9%.

From field observations, there were a number of misses over several feet long along the plant row as shown in FIGURE 8. The misses were attributed to the seed temporarily bridging over a meter (FIGURE 9). The AFMRC recommends the manufacturer modify the agitation bar to prevent seed bridging over the meter.

**Distribution Uniformity:** Uniformity of distribution of the application rate across the width of the Pickett bean planter was good. The seeding rate was very uniform for Pinto beans, corn, and Radley peas. The coefficient of variation<sup>1</sup> (CV) varied from 2 to 5% for Pinto beans, 2 to 8% for corn, and 2 to 7% for Radley peas.

<sup>1</sup>The coefficient of variation (CV) is the standard deviation of application rates from individual seed cups expressed as a percent of the average application rate. An accepted variation for seeding is a CV not greater than 15%. If the CV is less than 15%, distribution is acceptably uniform, whereas if the CV is greater than 15%, the variation in application rate among individual seed cups is excessive.

Higher CV's were obtained at lower application rates.



FIGURE 8. Seed Emergence Misses.

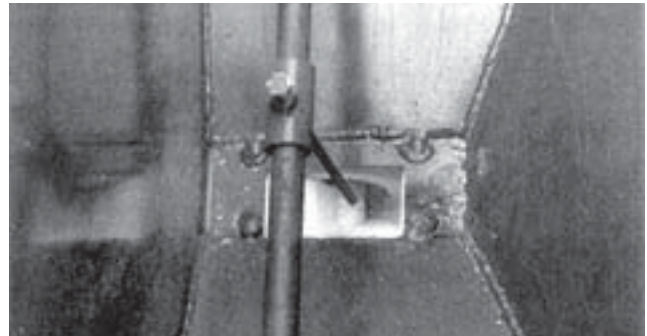

FIGURE 9. Agitation Shaft.

Field slope had an effect on the uniformity of distribution of the application rates. Increasing the slope to 15° to the right increased the CV from 4 to 15%. Increasing the downhill slope to 15° increased the CV from 4 to 13%.

Variations in ground speed had no significant effect on the uniformity of distribution of the application rates.

Uniformity of the inter-row seed spacing by the Pickett bean planter was unsatisfactory. The uniformity of the inter-row spacing was tested in the laboratory using Pinto beans, corn, and sunflowers. The ground speeds selected were 3 and 5 mph (4.8 and 8 km/h).

The results were recorded in terms of a Quality of Feed index. This index represents the percentage of seeds from the sample that were planted within the range of 0.5 to 1.5 times the desired seed spacing. TABLE 2 shows the Quality of Feed index of three seeds at two speeds. A Quality of Feed index below 75 percent is unsatisfactory for precision seeders.

TABLE 2. Quality of Feed Index results

| Seed Type          | Quality of Feed Index (%) |                |
|--------------------|---------------------------|----------------|
|                    | 3 mph (4.8 km/h)          | 5 mph (8 km/h) |
| Pinto Beans        | 23.8                      | 26.5           |
| Oil Seed Sunflower | 16.7                      | 26.3           |
| Grain Corn         | 25.2                      | 28.1           |

The Quality of Feed index for the seeds tested was unsatisfactory for precision seeders. The manufacturer indicated that the Pickett bean planter is not a precision seeder. While the Quality of Feed index for the planter was unsatisfactory, research on the effects of the index on edible bean yield is inconclusive.

**Seed Handling:** Seed handling was very good. Seed damage by the metering system was negligible.

#### EASE OF OPERATION AND ADJUSTMENT

**Maintenance:** Ease of performing routine maintenance on the Pickett bean planter was very good. Five minutes were required to lubricate the 10 grease fittings. Grease fittings were easily accessible. No service schedule was provided.

**Filling/Cleaning:** Ease of filling and cleaning the Pickett bean planter was fair. The seed box held 17.3 bu (630 L). The hopper was easy to fill with seed if the planter was in a lower position. The 9.5 in (241 mm) wide walkway was adequate for filling. The box lids could

not be locked in the open position.

The seed box was adequately sealed to prevent leakage during a rain. The box lids could not be latched shut. Strong winds blew the lids open. The AFMRC recommends the manufacturer modify the box lids so they can be locked in the open and closed positions.

The seed box emptied out evenly during the test. The 14.6 in (371 mm) wide seed box opening allowed a large pail to be used when cleaning large amounts of material out of the box. Seed in the bottom of the box was brushed through the feed cups. The agitator shaft in the seed box hindered this procedure. A vacuum cleaner or compressed air was faster and usually used during the test to clean small amounts of seed out of the box.

**Hitching:** Ease of hitching to the Pickett planter was good. One person could hitch or unhitch the planter from the test tractor in five minutes. Sway bars or stabilizing chains on the tractor were adjusted to minimize lateral tool bar movement. A centre support stand allowed for safe unhitching of the unit. As with all rear-mounted implements, careful backing up of the tractor was required to hitch the planter quickly.

The planter's lower hitch linkage required a 1.1 in (27.9 mm) diameter pin. The ASAE standard S217.1 requires a 1.3 to 1.4 in (33 to 35 mm) diameter hole for a Category II three-point hitch attachment. The AFMRC recommends the manufacturer modify the planter's lower hitch linkage to use standard 1.13 in (29 mm) pins in accordance with the ASAE standard S217.1.

Ease of levelling the planter was very good. The tractor's right and left hitch links controlled the lateral levelling. The tractor's top link controlled the fore and aft levelling.

**Transporting:** Ease of transporting the Pickett planter was very good. The unit was placed into transport position by the tractor's hydraulics (FIGURE 10). The transport lock on the tractor's three-point hitch hydraulic system locked the unit in transport position. The markers were secured to the planter when in the transport position.



FIGURE 10. Transport position.

Transport width of the test unit was 17.9 ft (5.5 m). Transport height was 11.5 ft (3.5 m). Overall weight of the unit full of seed was 3170 lb (1427 kg). Caution had to be taken when transporting because of the width, height and the weight of the unit. Safe operating speeds and the proper tractor ballasting required during field operations and while transporting the Pickett planter were not indicated.

The Pickett bean planter required a tractor with a Category II three-point hitch. A tractor with two sets of remote hydraulics was required to control the two field markers.

**Marking System:** Ease of operating and adjusting the marking system was very good. The unit was equipped with a row marker on each side. Each marker was operated independently from the tractor using a remote hydraulic.

The marker had two adjustments. The disc angle was varied by loosening a bolt and rotating the disc shaft. The length of the marker was adjusted by loosening two bolts and sliding the marker tube within the swing tube. The row markers had 5.5 ft (1.7 m) of adjustment.

**Monitoring:** Monitoring on the Pickett planter was unsatisfactory. No acre meter was provided. No motion indicator was provided for the metering shaft. No seed flow sensors on the meters were provided. The seed cups could not be viewed from the tractor. A plugged hose could not be detected during seeding. The AFMRC recommends the manufacturer offer an acre meter, seed

flow sensors and a metering shaft motion indicator as standard equipment.

**Application Rates:** Ease of changing the seeding rates was poor.

The seed metering rate was varied by lateral movement of the feed rolls and by the shaft speed as shown in FIGURE 11. The adjustment of a threaded rod varied the amount of the exposed feed roll. Two wrenches were needed to adjust the rod nut and jam nut. A tape measure was used to measure the exposed thread length for calibration. A slight adjustment of the adjustment rod affected the seeding rate significantly. For example, increasing the exposed length of the seed meter adjustment rod by 0.04 in (1 mm) increased a 69 lb/ac (77 kg/ha) metering rate of Pinto beans 15 percent.

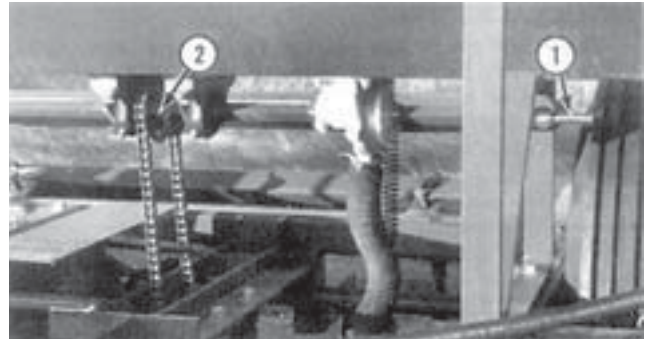

FIGURE 11. Seed Meter Adjustment: (1) Seed Meter Adjustment Rod, (2) Drive Sprockets.

The shaft speed was set by selecting one of two drive sprocket combinations. Five minutes were required to set the seeding rate. The AFMRC recommends the manufacturer modify the metering shaft adjustment rod for easier seed rate adjustment.

The Pickett planter was calibrated by removing a delivery hose from a seed cup. A collection bag was attached to the cup. The drive wheel was raised and turned a predetermined number of turns. Calibration of the planter took 30 minutes.

**Depth Adjustment:** Ease of setting the depth adjustment was fair. Each double-disk opener was individually adjusted in 1 in (25.4 mm) increments. Two people required 15 minutes to adjust the seed depth. Caution was required when working around the planter in the raised position.

The angle and lateral spacing of the double-covering discs were adjustable by loosening a bolt on each disc assembly.

## POWER REQUIREMENTS

**Draft Characteristics:** Draft (drawbar pull) requirements depended on previous field operations, soil texture, soil moisture content, ground speed and the amount of seed in the box.

Average draft was 719 lb (3200 N) for the 15 ft (4.6 m) test unit at a 2.5 in (63.5 mm) seeding depth at 5 mph (8 km/h) in tilled clay loam soil.

**Tractor Size:** Tractor size was dictated by the ability of the three-point hitch to lift the 3170 lb (1427 kg) planter with a full box, and provide stability when transporting.

A 76 PTO hp (57 PTO kW) tractor (with tire ballast and weights) had sufficient hydraulic lift capacity to operate the Pickett bean planter and provide the necessary stability in all conditions.

## OPERATOR SAFETY

The Pickett bean planter was safe to operate if normal safety precautions were observed. The transport ground clearance varied depending on the tractor, but was adequate with the tractor used during the test. The transport width of the test machine was 17.9 ft (5.5 m). The transport height with the test tractor was 11.5 ft (3.5 m). Caution was required when transporting on public roads, over bridges and through gates. The weight of the planter required the operator to transport the unit at safe operating speeds.

A slow moving vehicle sign was not provided by the manufacturer. The AFMRC recommends the manufacturer supply a slow moving vehicle sign as standard equipment.

The platform at the rear of the drill was large enough for safe filling of the seed box. The box lids could not be secured in the open position. This made filling in windy conditions dangerous.

Caution was taken when doing maintenance on the planter or adjusting the depth of the double-disk openers when the unit was in the raised position.

**OPERATOR'S MANUAL**

An operator's manual was not provided with the test unit. Information on safety, preparation, hitching, transporting, operation, calibration charts, attachments, trouble shooting and service should be contained in the operator's manual. The AFMRC recommends the manufacturer provide an operator's manual with the planter.

**MECHANICAL HISTORY**

The Pickett planter was operated for 68 hours while seeding 435 ac (174 ha). The intent of the test was evaluation of functional performance. An extended durability evaluation was not conducted. TABLE 3 outlines the mechanical problems that did occur during the functional testing.

TABLE 3. Mechanical history

| ITEM   | OPERATING           | FIELD AREA  |       |
|--|---------------------|-------------|-------|
|  | HOURS               | ac          | ha    |
| -Tightened numerous nuts                               | Throughout the test |             |       |
| -Row markers raised and lowered too fast               | Throughout the test |             |       |
| -Repaired the left row marker's disc assembly          | 1                   | 5           | 2     |
| -Repaired the left marker extension                    | 2, 8                | 15, 45      | 6, 18 |
| -Repaired a covering disc                              | 22                  | 145         | 58    |
| -Cross bar bent on the double-covering disc's assembly | 22                  | 145         | 58    |
| -Replaced a covering disk                              | 24                  | 160         | 64    |
| -Rezeroed one meter                                    | 24                  | 160         | 64    |
| -Replaced the right marker extension                   | 58                  | 382         | 153   |
| -Replaced three lost double-disc opener's dust covers  |                     | End of test |       |

**DISCUSSION OF MECHANICAL PROBLEMS**

**Double-Disc Opener Wear:** Wear on the double-disc openers was minimal. Average wear on the discs was 0.13 in (3 mm). Each double-disc opener seeded 73 ac (29.2 ha).

**Loose Fasteners:** Numerous fasteners were retightened on the planter throughout the test. There were several bolts on the test unit that were too short and the nuts were not properly engaged as shown in FIGURE 12. Industry standards require that 1.5 to 2 bolt threads be showing past the nut for maximum load carrying capacity of the nut.

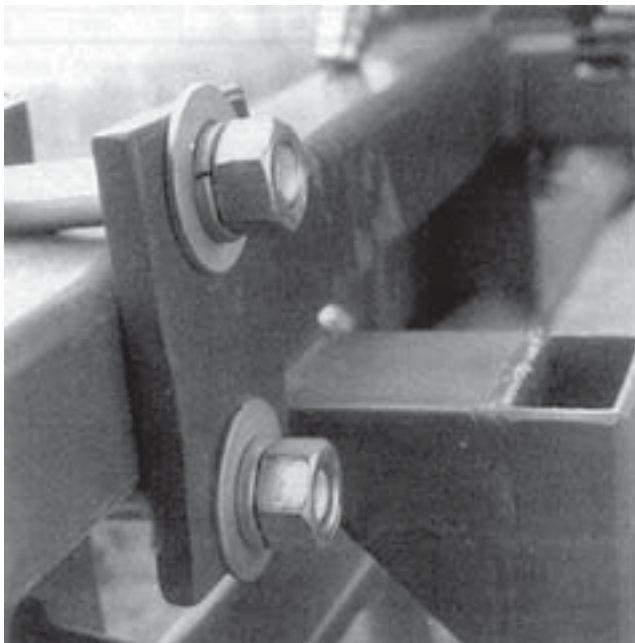

FIGURE 12. Short hitch linkage bolts.

The fasteners used on many areas of the planter were free spinning nuts with serrated faces. The serrated nuts required retightening under field vibration conditions. A more vibration tolerant fastener should be used. The AFMRC recommends the manufacturer review all of the bolted assemblies on the planter.

**Row Marker Extensions:** Both row marker extensions failed and

had to be repaired. The hydraulic system operated the markers too fast and occasionally hit the seed box's hinge when raised. The markers would also lower too fast bending the marker tube assembly. The AFMRC recommends the manufacturer install flow restrictors in the row marker's hydraulic lines for slower operation.

| APPENDIX I<br>SPECIFICATIONS                |   |
|---|---|
| <b>MAKE:</b>                                | Pickett Bean Planter  |
| <b>MODEL:</b>                               | 630   |
| <b>SERIAL NUMBER:</b>                       | 93-93   |
| <b>MANUFACTURER:</b>                        | Pickett Equipment<br>976 East Main<br>Burley, Idaho<br>USA 83318<br>Phone: (208) 678-9260 |
| <b>DIMENSIONS:</b>                          |   |
| -- length                                   | 4.8 ft (1.5 m)  |
| -- field width                              | 24.3 ft (4.7 m)   |
| -- height                                   | 9.8 ft (3.0 m)  |
| -- transport width                          | 17.9 ft (5.5 m)   |
| -- height                                   | 11.5 ft (3.5 m)   |
| -- effective planting width                 | 15.0 ft (4.6 m)   |
| <b>SEEDING SYSTEM:</b>                      |   |
| -- type                                     | internal fluted feed rollers  |
| -- number of rows                           | 6   |
| -- number of seed hoppers                   | 1   |
| -- seed hopper capacity                     | 17.3 bu (631 L)   |
| -- row spacing                              | 30 in (762 mm)  |
| -- type of drive                            | chain driven from ground wheel  |
| -- type of adjustment                       | threaded rod controlling feed inlet size and sprocket combinations                        |
| -- seed disc opener diameter                | 13.9 in (352 mm)  |
| -- seed disc opener range of vertical force | 58 to 147 lb (258 to 654 N)   |
| -- covering discs diameter                  | 9.8 in (247 mm)   |
| <b>TIRES:</b>                               |   |
| -- number                                   | 2   |
| -- size                                     | 7.60-15 SL, 6-ply   |
| <b>HITCH:</b>                               |   |
| -- type                                     | three point   |
| -- linkage category                         | Category II   |
| <b>WEIGHT:</b>                              |   |
| -- hopper empty                             | 2080 lb (936 kg)  |
| -- hopper full of edible beans              | 3170 lb (1427 kg)   |
| <b>NUMBER OF LUBRICATION POINTS:</b>        | 10 grease fittings; four wheel bearings   |
| <b>NUMBER OF CHAIN DRIVES:</b>              | 2   |
| <b>NUMBER OF HYDRAULIC CYLINDERS:</b>       | 2   |

| APPENDIX II<br>MACHINERY RATINGS  |                |
|---|----------------|
| The following rating scale is used in Alberta Farm Machinery Research Centre Evaluation Reports |                |
| Excellent   | Very Good      |
| Good  | Fair           |
| Poor  | Unsatisfactory |

## SUMMARY CHART

### PICKETT BEAN PLANTER

|  |   |
|--|---|
| <b>RETAIL PRICE:</b>                     | \$11,352.00 (March, 1994 f.o.b. Lethbridge, Alberta)  |
| <b>QUALITY OF WORK:</b>                  |   |
| - penetration                            | <b>very good;</b> in secondary tillage conditions   |
| - seed placement                         | <b>good;</b> double-disc openers provided consistent seed depth                                     |
| - soil finishing                         | <b>good;</b> poor seed emergence  |
| - marking system                         | <b>very good;</b> visible mark in all soil conditions   |
| - stone condition                        | <b>fair;</b> double-covering disks have limited trip clearance                                      |
| - metering accuracy                      | <b>good;</b> no calibration charts provided   |
| - distribution uniformity                |   |
| - across the width                       | <b>good</b>   |
| - inter-row                              | <b>unsatisfactory;</b> low Quality of Feed index  |
| - seed handling                          | <b>very good;</b> seed damage was negligible  |
| <b>EASE OF OPERATION AND ADJUSTMENT:</b> |   |
| - maintenance                            | <b>very good;</b> 10 grease fittings  |
| - filling/cleaning                       | <b>fair;</b> box lids could not be secured open or latched shut                                     |
| - hitching                               | <b>good;</b> took one person five minutes   |
| - transporting                           | <b>very good</b>  |
| - levelling                              | <b>very good</b>  |
| - marking system                         | <b>very good</b>  |
| - monitoring                             | <b>unsatisfactory;</b> no acre meter, seed flow monitor or metering shaft motion indicator provided |
| - application rates                      | <b>poor;</b> rate was inconvenient to change  |
| - depth adjustment                       | <b>fair</b>   |
| <b>POWER REQUIREMENTS:</b>               | 76 PTO hp (57 PTO kW) tractor was necessary to operate planter                                      |
| <b>OPERATOR SAFETY:</b>                  | <b>safe;</b> if normal precautions observed   |
| <b>OPERATOR'S MANUAL:</b>                | none provided   |
| <b>MECHANICAL HISTORY:</b>               | numerous loose bolt assemblies, repaired row marker extensions                                      |



3000 College Drive South  
Lethbridge, Alberta, Canada T1K 1L6  
Telephone: (403) 329-1212  
FAX: (403) 329-5562  
<http://www.agric.gov.ab.ca/navigation/engineering/afmrc/index.html>

#### Prairie Agricultural Machinery Institute

Head Office: P.O. Box 1900, Humboldt, Saskatchewan, Canada S0K 2A0  
Telephone: (306) 682-2555

Test Stations:  
P.O. Box 1060  
Portage la Prairie, Manitoba, Canada R1N 3C5  
Telephone: (204) 239-5445  
Fax: (204) 239-7124

P.O. Box 1150  
Humboldt, Saskatchewan, Canada S0K 2A0  
Telephone: (306) 682-5033  
Fax: (306) 682-5080