

EVALUATION REPORT

377



Allis-Chambers 330 Air Champ Row Crop Planter

A Co-operative Program Between



ALLIS-CHALMERS 330 AIR CHAMP ROW CROP PLANTER

MANUFACTURER:

Allis-Chalmers
Agricultural Equipment
Box 512
Milwaukee, Wisconsin
53201 U.S.A.

DISTRIBUTOR:

Allis-Chalmers Agricultural
Equipment of Canada
515 Dewdney Ave.
Regina, Saskatchewan
S4P 3A1

RETAIL PRICE:

\$18,486.00 Canadian Funds (July 1984, f.o.b. Portage la Prairie, Manitoba) 6 row, with granular fertilizer hoppers, horizontal fertilizer auger fill system, depth gauge wheels, and ACP-3 Monitor.

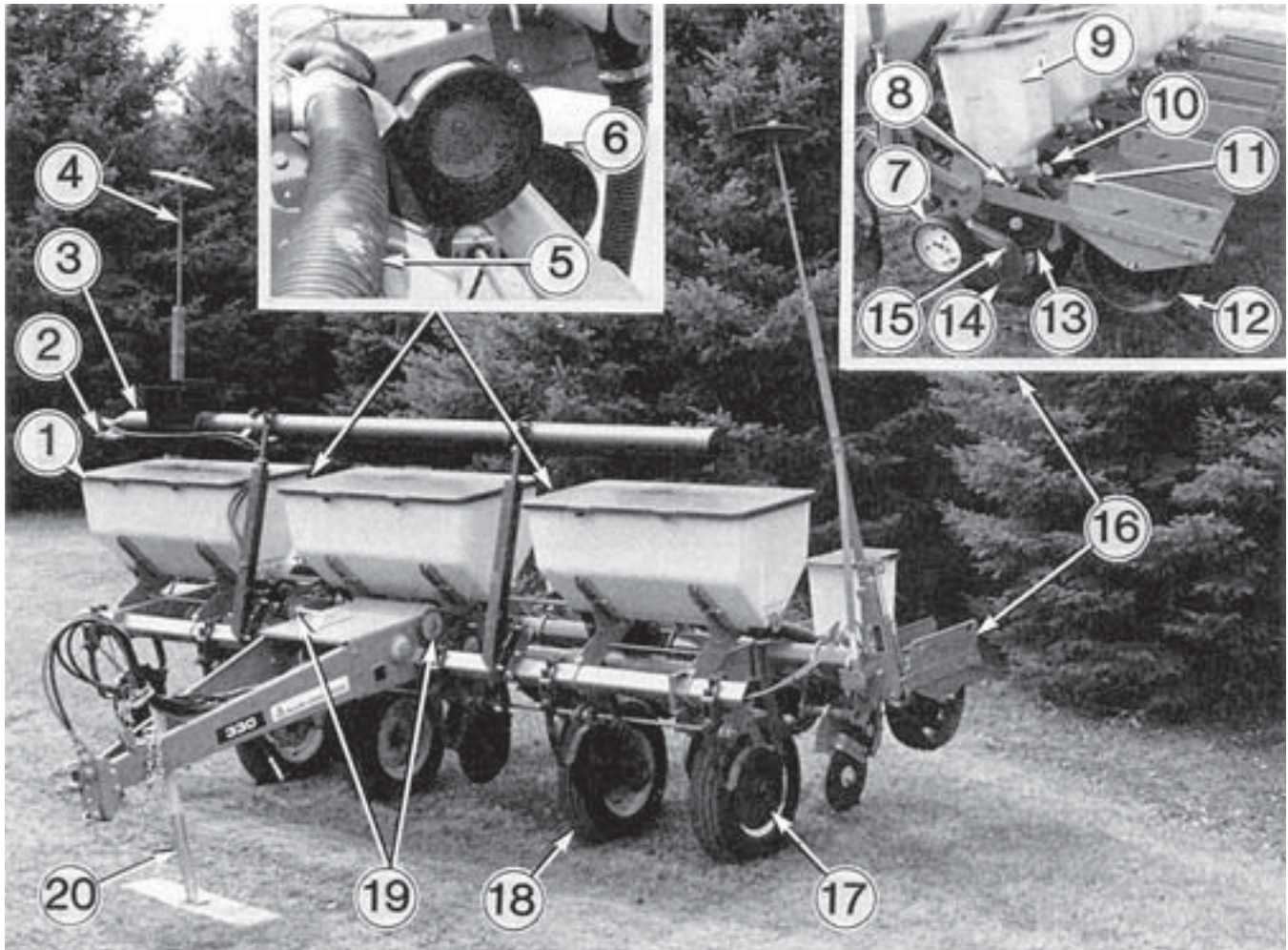

FIGURE 1. Allis-Chalmers 330 Air-Champ: (1) Granular Fertilizer Hoppers, (2) Hydraulic Flow Control Valve, (3) Horizontal Fertilizer Auger Fill System, (4) Hydraulic Row Marker, (5) Air Hose, (6) Electric Blower, (7) Optional Depth Gauge Wheels, (8) Seed Hopper Shut-Off Gate, (9) Seed Hopper, (10) Seed Hopper Thumb Nut Latch, (11) Depth Adjustment, (12) Press Wheel, (13) Seed Disk, (14) Seed Disk Openers, (15) Seed Disk Opener Scrapers, (16) Seed Unit, (17) Fertilizer Disk Openers, (18) Ground Wheels, (19) Fertilizer Drive Transmission, (20) Safety Stand.

SUMMARY AND CONCLUSIONS

Functional performance of the Allis-Chalmers 330 Air Champ crop planter was evaluated in a wide variety of field conditions.

Seed Metering: The spacing of corn seed at 5 mph (8 km/h) using the seed disk metering and air pressure system was very good¹, particularly when planting small round or small plateless seed. When using flat corn seed or increasing ground speed, the seed spacing accuracy of this system was reduced. However, results did not vary significantly from one row to the next. Spacing of large sunflower seed was not as accurate as the spacing of corn seed.

Actual overall population rates were excellent for white beans and soybeans when compared to rates stated in the operator manual. Operating on 11° slopes had little effect on the accuracy of the system when planting corn but adversely affected the spacing of sunflower seed on sideslopes.

Fertilizer Application: Actual fertilizer rates were up to 19% higher than the rates stated in the fertilizer chart.

Penetration: Penetration of the seed and fertilizer disk openers was very good in all field conditions tested. Seeding depth control was much better when the optional depth gauge wheels were used.

Soil Finishing: Coverage of seed was good in most field conditions tested, particularly at 5 mph (8 km/h). Soil was pushed on top of the seed by the outer edges of the press wheels. The centre of the press wheels then slightly compacted the soil over the seed. In sandy soils the seed was placed in a range of less than one inch on either side of the centre line. In some clay soils the seed was not always covered. The optional seed disk covers (closing wheels) improved seed coverage.

Monitor: The ACP-3 monitor supplied with the test machine, provided an accurate seed count for corn only. A chart was used to convert the readout into seeds/acre. Sensors in the seed tubes were cleaned daily.

¹See Rating Table APPENDIX II

Ease of Operation and Adjustment: Seeding rates and fertilizer rates were adjusted by selecting sprocket combinations on two centrally located sprocket drive transmissions. The sprockets, held in place by retaining rings and klik pins, could be quickly removed from the transmissions. Seeding depth was changed by adjusting the depth adjustment pin on each row. The planter had to be in the raised position.

The six seed hoppers were conveniently filled from the rear of the machine. The three large granular fertilizer hoppers were filled using the optional horizontal fertilizer auger.

The 330 Air Champ had very good stability on roads at speeds up to the manufacturer's recommended maximum speed of 20 mph (32 km/h).

Power Requirements: A 55 HP (41 kW) tractor is the minimum tractor size recommended. The tractor must be equipped with a minimum 32 amp alternator.

Operator Safety: The Allis-Chalmers 330 Air Champ row crop planter was safe to operate provided normal safety precautions were observed. In addition, the seed hopper lids should not be removed when the system is pressurized to prevent dust and chemicals from being dispersed into the air around the operator.

Operator Manual: The operator manual was very good. Clear illustrations and well written text provided instruction on safety, operation and maintenance of the machine. Both Imperial and SI units of measurement were used in the text.

Mechanical Problems: Chain tighteners for the drive chains had a wear life of only 500 acres (200 ha). Also, scrapers for the seed disk openers had a wear life of 750 acres (305 ha). At the end of the tests, weld failures on the tongue frame were noticed. Close inspection indicated that proper weld penetration had not been achieved.

RECOMMENDATIONS

It is recommended that the manufacturer consider:

1. Designing a new sunflower seed disk or providing a means of adjusting air pressure for planting sunflowers.
2. Recalibrating the fertilizer rate chart.
3. Including the optional depth gauge wheels as standard equipment.
4. Modifying the optional seed disk covers for improved installation and adjustment.
5. Modifying the hydraulic row markers to improve stability and performance.
6. Improving the quality of drive chain tighteners for longer wear life or use sprockets or rollers instead of the rigid tighteners.
7. Improving the quality of the seed disk opener scrapers for longer wear life.
8. Improving quality control regarding welding on the planter frame.

Senior Engineer -- G.M. Omichinski

Project Engineer -- C. W. Bolton

THE MANUFACTURER STATES THAT

With regard to recommendation number:

1. A good match of seed to seed disk pocket size is important for obtaining optimum planting rates and spacing. Any of the 45 cell corn disks can be used for planting sunflowers and a disk with large or extra large pockets should give satisfactory results when planting large sunflower seeds.
2. Data in the fertilizer output charts shown in the supplement to the operator's manual are based on actual tests using fertilizer with a bulk density of 61 lb. per cubic foot. Deviations to these data can result due to the wide variety of material composition, and trial runs should be made in the field to determine actual output.
3. Depth gauge wheels will not be made standard equipment on model 330 planters, but this will be given consideration on future designs.
4. A wide range of adjustments is provided for the optional covering disk attachments to make it adaptable to other units. This adaptability requires more adjustment than might otherwise be necessary.

5. The need for greater row marker stability, especially in current reduced tillage situations, is recognized. While the model 330 is not considered to be a minimum tillage planter, future row marker design will tend toward heavier construction with greater marking capability. Speed of marker cycle time (both raise & lower) can be increased by enlarging the orifice in the restrictor located at the sequence valve. The 0.031 in (0.78 mm) hole size was selected as optimum for safety and reliability. Care should be taken not to increase this diameter beyond 0.046 in (1.17 mm).
6. Over tightening of chains should be avoided to minimize wear on the cast idler blocks. Future designs will utilize sprockets or rollers to increase idler life.
7. Disk scrapers are considered to be expendable items and have not been a high warranty item on previous and current model planters.
8. Numerous changes in weld specifications have been made on the planter main frame to improve reliability.

GENERAL DESCRIPTION

The six-row Allis-Chalmers 330 Air Champ row crop air planter tested is designed to plant crops such as corn, sunflowers, beans, sugar beets and sorghum.

The six seeding units, spaced 30 in (76 cm) apart are mounted on the back of the tool bar. Each unit consists of a 1.25 bu (46 L) seed hopper, seed disk-metering system, an air hose from an electric blower, two seed disk openers, and a press wheel. The unit tested was equipped with optional depth gauge wheels.

Seed from the seed hopper falls by gravity into a small chamber located at the base of the seed disk (FIGURE 2). This is a rotating, vertical plastic disk with seed pockets around the outer circumference. Ten different seed disks are available for a variety of crops and sizes of seed. Individual seeds are picked up and held in the seed pockets by air pressure. Air pressure is created by two electric blowers (one for every three rows). The speed at which the seed disk rotates is determined by the ground speed and the sprocket combination selected on the central seed drive transmission. A plastic coated foam seed pad removes excess seeds from the seed pocket and "cuts off" the air pressure and allows the seed to fall down the short seed delivery tube to the ground.

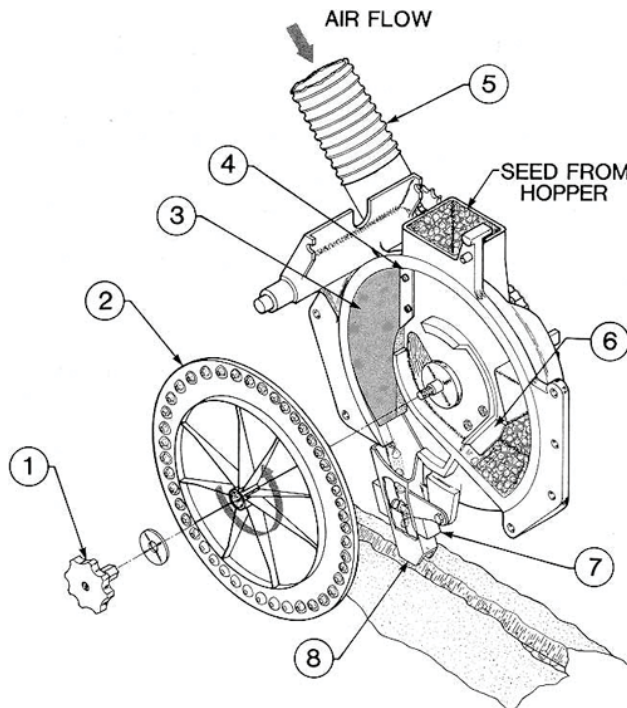

FIGURE 2. Seed Metering System: (1) Thumb Screw, (2) Seed Disk, (3) Seed Pad, (4) Seed Pad Clip, (5) Air Hose, (6) Seed Baffle, (7) Seed Sensor, (8) Seed Delivery Tube.

The two 12 in (32 cm) seed disk openers cut a narrow furrow in the soil. The depth of this furrow is controlled by either the press

wheel or the optional gauge wheels. Once the seed is placed in the furrow, it is covered with soil by the hill forming press wheel.

The six-row planter tested, was equipped with three optional 9.1 ft³ (260 L) fiberglass, granular fertilizer hoppers. Fertilizer is placed in the ground by double disk openers. The rate of application is determined by selecting one of two spring augers and a sprocket combination on the fertilizer drive transmission.

The planter can be equipped with the ACP-3 monitor (FIGURE 3). In addition to the visual display lights, the monitor signals planting malfunctions with an alarm. Parameters that can be measured by the monitor include sequentially scanning each row and displaying the population rate for 15 second intervals. Also, a particular row can be selected and monitored for the 15 second interval or a continuous count.

Detailed specifications are given in APPENDIX I.



FIGURE 3. ACP-3 Monitor.

SCOPE OF TEST²

The Allis-Chalmers 330 Air Champ row crop planter was operated in various field conditions (Table 1) for about 158 hours while seeding 645 ac (360 ha) of corn, 300 ac (127 ha) of sunflowers and 230 ac (94 ha) of white beans. It was evaluated for quality of work, ease of operation and adjustment, rate of work, power requirements, operator safety and suitability of the operator manual.

In addition to field testing, the seed and fertilizer metering systems were tested in the laboratory for accuracy on level and sloped operating conditions.

TABLE 1. Operating Conditions

FIELD CONDITIONS	HOURS	FIELD AREA	
		ac	ha
Soil type:			
-- clay	33	240	97
-- clay loam	53	405	165
-- sandy loam	38	280	113
-- sand	34	250	100
Total:	158	1175	476
Trash cover:			
-- heavy	35	250	100
-- light	87	660	268
-- none	36	265	108
Total:	158	1175	476

RESULTS AND DISCUSSION

QUALITY OF WORK

Seed Metering: Accuracy of the seed disk metering system was tested in the laboratory using eight different samples of corn and samples of large sunflowers, white beans and soybeans. The ground speeds selected were 5 mph (8 km/h), considered an average planting speed, and 7 mph (11 km/h), the maximum speed recommended by the manufacturer for the crop and seeding rate being tested.

The results were recorded in terms of a Quality of Feed Index³. This index represents the percentage of seeds from the samples that were planted within the range of 0.5 to 1.5 times the desired seed spacing. Table 2 shows the Quality of Feed Index of eight different corn samples at a seeding rate of 26,500 seeds/ac (66,250 seeds/ha) on a level surface, when using the two sizes of seed pads. The results did not vary significantly on different rows. An index of 95% or better was considered to be excellent.

TABLE 2. Quality of Feed Index Results for Corn at 5 mph (8 km/h)

Corn Size	Quality of Feed Index	
	Short Seed Pad	Long Seed Pad
Small, plateless	99	97
Small, round	97	97
Medium, round	96	95
Large, round	96	94
Medium, flat	93	87
Large, plateless	92	90
Large, flat	90	89
Small, flat	89	86

The most accurate results were achieved when using the short seed pad, particularly with small plateless and small round seed. All seed samples except the small flats had a Quality of Feed Index greater than 90% at 5 mph (8 km/h). An increase in speed to 7 mph (11 km/h) caused the Quality of Feed Index to drop 3% to 6% depending upon the seed sample.

Test results showed that the seed spacing did not vary from one seeding unit to the next. Doubles (spaces less than 0.5 times the desired seed spacing) occurred more often than misses (spaces greater than 1.5 times the desired seed spacing) thus indicating that the planter had a slight tendency to over populate.

The Quality of Feed Index for large sunflower seed at a population rate of 21,100 seeds/ac (52,750 seeds/ha) was 71% at 5 mph (8 km/h). This was considered to be unsatisfactory. It is recommended that the manufacturer consider designing a new seed disk or changing the amount of air pressure in the seeding system for planting sunflowers.

Actual population rates for white beans and soybeans were within 1% of the theoretical rates stated in the operator manual, when using the long seed pad and having the seed baffle removed. These results were based on seeding rates of 118,100 seeds/ac (291,800 seeds/ha).

While operating on 11° slopes, a decrease in the Quality of Feed Index of 0 to 3% occurred when using corn seed.

However, when planting sunflower seed, on sideslopes, a sharp increase in the frequency of misses caused the Quality of Feed Index to drop by 10%. This problem also occurred when using small flat seed on slopes where the seed was sloped away from the seed disk.

Fertilizer Application: The "standard capacity" auger springs used in the fertilizer hoppers were tested for metering accuracy in the laboratory.

The application rates in the operator manual (based on 61 lb/ft³) were adjusted slightly to compensate for the difference in density of the test sample (55 lb/ft³). TABLE 3 shows that the actual application rates were 15% to 19% higher than stated in the operator manual for rates up to 400 lb/ac (452 kg/ha). Actual rates were up to 40% higher for rates above 400 lb/ac (452 kg/ha).

TABLE 3. Fertilizer Rates

Sprocket Setting	Machinery Institute		Manufacturer		% Difference
	lb/ac	kg/ha	lb/ac	kg/ha	
20-36-16-36	85	96	74	84	+15
24-20-16-36	187	211	160	181	+17
28-24-16-20	332	375	280	316	+19
32-28-36-36	404	457	342	386	+18
36-32-36-20	851	962	607	686	+40
36-20-36-20	1358	1535	971	1097	+40

Although a supplement chart to the operator manual was supplied by the manufacturer, actual rates were 19 to 28% less than those stated in the supplement chart. It is recommended that the manufacturer consider recalibrating the fertilizer rate chart.

Operating up and down 11° slopes increased fertilizer rates 10 to 21% when compared to operating on level ground. Operating on 11° side slopes caused 6 to 60% more fertilizer to be delivered to downspouts at the lower end of the hoppers and 32 to 39% less fertilizer delivered to downspouts at the higher end of the hoppers.

Penetration: Penetration of the seed and fertilizer disk openers was very good in all field conditions tested. The vertical force of the fertilizer disk openers was 350 lbs (1560 N).

Seeding Depth: Seeding depth was very good in most field conditions when using the optional depth gauge wheels. At 5 mph (8 km/h) nearly all the seed was placed within 0.5 in (13 mm) of the average seeding depth. However, when the optional depth

²Prairie Agricultural Machinery Institute Detailed Test Procedure for Row Crop Planters.

³International Organization for Standardization ISO/DIS 7256/1 Sowing Equipment-Method of Test-Part 1: Single Seed Drills (Precision Drills).

gauge wheels were not used, the seeding depth varied as much as 1.4 in (36 mm) from the average depth. It is recommended that the manufacturer consider including the depth gauge wheels as standard equipment.

Soil Finishing: Placement and coverage of seed with this system was considered to be good. The outer edges of the press wheel pushed the soil back into the furrow. The centre of the press wheel gently compacted the soil over the seed forming a very small hill of soil. The amount of force exerted by the press wheel was adjustable. Final placement of the seed was in a range of less than one inch on either side of the centre line. In some heavy clay soils and damp conditions, the furrow was not always completely closed and seed was left uncovered. The optional 8 in (203 mm) seed disk covers were installed. These covers improved seed coverage in the clay soils, however, they were awkward to install and “set up” for satisfactory operation. Frequent adjustment was also necessary. It is recommended that the manufacturer consider modifying the seed disk covers to improve installation and adjustment.

Row Markers: The hydraulic row markers were slow to reach the ground when the planter was lowered. Also, the marker disks on the ends of the row markers did not always leave a clear mark for the operator to follow. Performance of the marker disks was greatly improved by increasing the curve in the rods holding the marker disks. In some conditions the motion of the row markers was jerky and uneven. It is recommended that the manufacturer consider modifying the row markers to improve stability and performance.

Monitor: An ACP-3 monitor (FIGURE 3) was supplied with the test machine. The ability of the monitor to scan the rows and measure population rates for 15 second intervals was very good (for corn only, as stated in the manual). A table was printed on top of the monitor to convert the 15 second count into seeds/acre for a range of ground speeds. This table was also included in the operator manual.

EASE OF OPERATING AND ADJUSTMENT

Hitching: When hitching the planter to the tractor drawbar, a suitable drawpin was used and the safety chain secured. Hitching was completed by connecting two sets of hydraulic hoses and two electrical pin connectors for the monitor and electric blowers.

Application Rates: Planting rates were changed on the seed drive transmission (FIGURE 4), which was centrally located on the planter. The seed drive transmission consisted of two sets of sprockets. One set was changed by loosening an idler sprocket and removing two klik pins and the sprockets. The desired sprockets were then selected and the chain retightened using the adjustable idler sprocket. The second set of sprockets was adjusted by loosening the chain and a setscrew on the sprocket cluster. The desired sprocket was then aligned with the sprocket on the common drive shaft.

Thirty-five different sprocket combinations were possible, allowing the seed population to vary from 12,800 to 74,600 seeds/ac (31,600 to 184,200 seeds/ha) when using a 45 pocket seed disk.

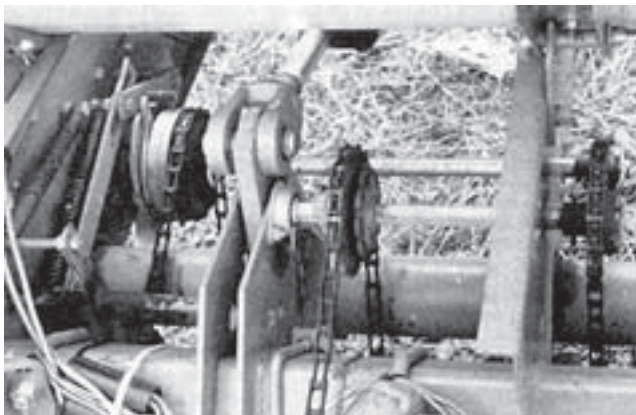

FIGURE 4. Seed Drive Transmission.

Air pressure created by the electric blowers, was not adjustable.

The fertilizer application rate could be varied by either changing the fertilizer auger springs or changing the sprocket combinations.

Only the “standard capacity” set of auger springs were supplied with the test machine.

The fertilizer drive transmission consisted of two sets of sprockets. A total of sixty-five different sprocket combinations were possible allowing the operator to select settings within the range stated in the operator manual between 82 and 1077 lb/ac (92 to 1207 kg/ha) based on a fertilizer with a density of 61 lb/ft³ (977 kg/m³).

The sprockets which were held in place by retaining rings and klik pins were changed the same way as the sprockets in the seed drive transmission. Extra sprockets were stored on the side of the planter tongue.

Depth Adjustment: When using either the press wheels or the optional depth gauge wheels, adjustments could be done easily with the planter raised. Using the depth stops and quick pins on the press wheels the operator could make depth changes of 0.25 in (6 mm) increments. Adjusting depth by the gauge wheels, allowed depth changes of 0.19 in (5 mm) increments.

Due to minor variations in the seed planting units, the depth adjustment pins were not always in exactly the same position on every row.

Lubrication: Access to most lubrication points was very good. There were 9 pressure grease fittings that required either daily or weekly servicing.

A complete service schedule was provided in the operator manual.

Filling: The six, 1.25 bu (46 L) seed hoppers were easy to fill with seed especially if the planter was in a lowered position. The air system was not pressurized when filling the hoppers.

The three, 9.1 ft³ (260 L) granular fertilizer hoppers were easily filled with the optional, hydraulically driven, horizontal fertilizer auger fill system. Fertilizer was put in the small hopper on the end of the auger. At the other end of the auger the fertilizer hopper was often overfilled as fertilizer came out the end of the auger over the stop before all three hoppers were filled.

Straps held the fertilizer hopper lids at the back of the hoppers when filling.

Cleaning: The sensors in the seed tubes were cleaned daily using a small round brush and mild detergent and water.

The seed hoppers were easy to clean out. After closing the seed hopper shut-off gates and loosening thumbnut latches, the seed hoppers could be removed and the seed emptied from the hoppers. A small amount of seed was left in each of the seed metering units and could be removed by taking off the seed disks.

To clean the fertilizer hoppers, the operator had to disconnect the fertilizer downspout hoses, the fertilizer drive shaft, and remove two pins at the back of each hopper. The hoppers were then tipped forward and the fertilizer removed.

Transporting: The 330 Air Champ had very good stability on roads up to the manufacturer’s recommended maximum speed of 20 mph (32 km/h).

One person could put the planter in transport position from field position in a couple of minutes. Additional time was necessary to remove the drive chains for long distance transporting. It was important to ensure that the fertilizer and seed hoppers were less than half full to prevent excessive loading on the planter frame and prevent settling of seed and fertilizer in the hoppers. Also, all locks were engaged.

Transport height was 9.2 ft (2.8 m) and transport width was 15.4 ft (4.7 m).

Power requirements: Power requirements depended upon soil conditions, seeding depth and ground speed. Draft tests showed that a tractor with at least 55 HP (41 kW) maximum power take-off rating, based on the Nebraska tractor test data, should be used to operate this machine.

Also, the operator manual stated that the tractor must have a minimum 32 ampere alternator. The tractor used with the test machine, was equipped with a 61 ampere alternator. Tests showed that the electric blowers draw 16.8 amps of current from the alternator when the seed disks were full of seed and 22.0 amps when the seed disks were empty.

OPERATOR SAFETY

The Allis-Chalmers 330 Air Champ row crop planter was safe to operate and service if normal safety precautions were observed.

Care was taken when transporting to ensure all safety locks were engaged and ground speed was selected to maintain machine stability. Also, the seed hopper lids should not be opened if the system is pressurized because dust and chemical dispersed into the air may be hazardous to the operator.

OPERATOR MANUAL

The operator manual supplied with the test machine was very good. Many photographs and illustrations were included with the text, providing useful, easy to understand information on maintenance, adjustment, service and safe operation of the machine. Seeding rate and fertilizer rate charts were also provided in the operator manual.

DURABILITY

TABLE 4 outlines the mechanical history of the Allis-Chalmers 330 Air Champ row crop planter during 158 hours of operation while seeding 1175 ac (476 ha).

TABLE 4. Mechanical History

ITEM	OPERATING HOURS	FIELD AREA	
		ac	ha
-Drive chain idler blocks replaced at	70	500	(200)
-Seed disk opener scrapers replaced at	105	750	(305)
-Drive chain idler blocks replaced at	130	975	(395)
-Weld failures on tongue frame occurred at	158	1175	(476)

As shown in TABLE 4 the tighteners or idler blocks used to keep the drive chains tight were replaced after 500 ac (200 ha) and again after 975 ac (395 ha) of use. It is recommended that the manufacturer consider improving the quality of these idlers for longer wear life or use sprockets or rollers instead of the rigid idler blocks.

The seed disk opener scrapers were replaced after 750 ac (350 ha). It is recommended that the manufacturer consider improving the quality of these scrapers for longer wear life.

The weld failures on the tongue frame (FIGURE 5) were probably caused by poor penetration of the welds. It is recommended that the manufacturer consider improving quality control regarding welding on the planter frame.

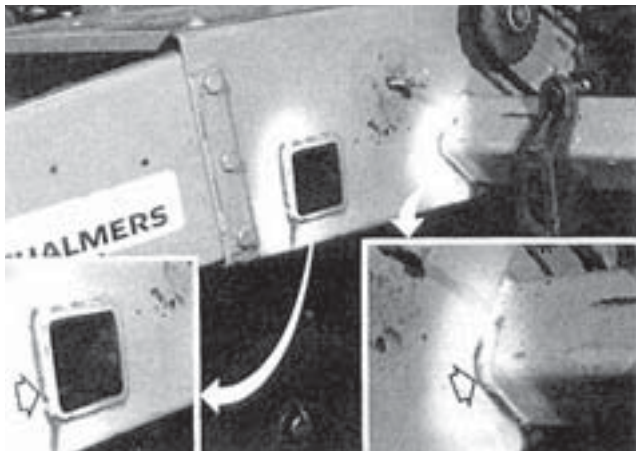

FIGURE 5. Weld Failures on Tongue Frame.

The intent of the test was evaluation of functional performance. An extended durability evaluation was not conducted.

**APPENDIX I
SPECIFICATIONS**

MAKE:	Allis-Chalmers
MODEL:	330 Air Champ
SERIAL NUMBER:	19038
DIMENSIONS:	
-- Transport	
-width	15.4 ft (4.7 m)
-height	9.2 ft (2.9 m)
Effective planting width	15.0 ft (4.6 m)
SEEDING SYSTEM:	
-- type	Air
-- number of rows	6
-- number of seed hoppers	6
-- row spacing	30 in (76 cm)
-- seed hopper capacity (individual)	1.25 bu (46 L)
-- type of drive	chain driven from ground
-- type of adjustment	wheel sprocket combinations
-- air pressure range	3.0 in H ₂ O (0.75 kPa)
-- seed disk opener diameter	12 in (32 cm)
-- optional depth gauge wheel size	4.25 x 11.5 in (110 x 290 mm)
-- press wheel size	7.0 x 18 in (180 x 460 mm)
-- seed disk opener	
-range of vertical force	
(when seed hopper is empty)	175 lb (780 N)
-- press wheel range of vertical force	70 - 85 lb (310-380 N)
FERTILIZER SYSTEM:	
-- type	Auger
-- number of rows	6
-- number of fertilizer hoppers	3
-- each fertilizer hopper capacity	9.1 ft ³ (260 L)
-- type of drive	chain driven from ground wheel
-- type of adjustment	auger and sprocket combinations
-- fertilizer disk opener diameter	13.5 in (34.3 cm)
-- fertilizer disk opener maximum applied vertical force	350 lb (1558 N)
TIRES:	4, 7.6 x 15, 6-ply
NUMBER OF LUBRICATION POINTS:	
-- pressure grease fittings	9
-- oil points	24
-- sealed wheel bearings	4
NUMBER OF CHAIN DRIVES:	21
NUMBER OF HYDRAULIC CYLINDERS:	3
OPTIONAL EQUIPMENT:	
-- liquid fertilizer tank	
-- granular insecticide and herbicide hoppers	
-- minimum till and no-till fluted coulters	
-- depth gauge wheels	
-- horizontal fertilizer auger fill system	
-- variety of press wheels	
-- down pressure springs	
-- disk covers	
-- knife covers	
-- seed press wheels	
-- variety of seed disks	
-- disk furrows	
-- one other monitor	

**APPENDIX II
MACHINE RATINGS**

The following rating scale is used in Machinery Institute Evaluation Reports:

Excellent	Fair
Very Good	Poor
Good	Unsatisfactory

**APPENDIX III
CONVERSION TABLE**

Acre (ac) x 0.405	= Hectare (ha)
Foot (ft) x 0.305	= Metre (m)
Inches (in) x 25.4	= Millimetres (mm)
Horsepower (hp) x 0.74	= Kilowatt (kW)
Miles/Hour (mph) x 1.61	= Kilometre/Hour (km/h)
Pounds Mass (lb) x 0.454	= Kilogram (kg)
Pounds Mass/Cubic Foot (lb/ft ³) x 16.02	= Kilograms/cubic metre (kg/m ³)
Pounds Force (lb) x 4.45	= Newton (N)
Pounds Force/Foot (lb/ft) x 14.6	= Newton Metre (N/m)
Pounds Force-Feet (lb-ft) x 1.36	= Newton-Metre (N-m)
Inches of Water (in H ₂ O) x 0.249	= Kilopascal (kPa)
Cubic Feet (ft ³) x 28.6	= Litres (L)
Bushel (bu) x 36.4	= Litres (L)
Pounds/Acre (lb/ac) x 1.13	= Kilograms/Hectare (kg/ha)
Seeds/Acre (seeds/ac) x 2.5	= Seeds/Hectare (seeds/ha)

SUMMARY CHART

ALLIS-CHALMERS 330 AIR CHAMP ROW CROP PLANTER

RETAIL PRICE: \$18,486.00 Canadian Funds (July 1984, f.o.b. Portage la Prairie, Man.) 6 row, with granular fertilizer hoppers, horizontal fertilizer auger fill system, depth gauge wheels and ACP-3 Monitor.

QUALITY OF WORK		
Seed Metering	Good	-best results with small plateless and small round seed.
Fertilizer Application	Fair	-poor sunflower seed spacing -actual rates up to 19% higher than rates stated in the operator manual.
Penetration	Very Good	-optional depth gauge wheels helped maintain constant seeding depth.
Soil Finishing Monitor	Good Very Good	-did not always provide good coverage in clay soils. -a chart is used to convert readout to seeds/acre.
EASE OF OPERATION AND ADJUSTMENT		
Application Rates	Very Good	-two sprocket drive transmissions.
Filling	Very Good	-optional horizontal fertilizer auger fill system was used in tests.
Transporting	Very Good	-maximum recommended speed 20 mph (32 km/h).
POWER REQUIREMENTS		
		-55 hp (41 kW) minimum. -32 ampere alternator minimum.
OPERATOR SAFETY		
	Good	-avoid opening pressurized seed hoppers.
OPERATOR MANUAL		
	Very Good	-well written and clearly illustrated.
MECHANICAL PROBLEMS		
		-short wear life of seed disk opener scrapers. -very short wear life of drive chain tighteners. -poor weld penetration on tongue frame.
CAUTION		
This summary chart is not intended to represent all of the final conclusions of the evaluation report. The relevance of the ratings is secondary to the information provided in the full text of the report. It is not recommended that a purchase decision be based only on the summary chart.		

 <p>ALBERTA FARM MACHINERY RESEARCH CENTRE</p>	<p>Prairie Agricultural Machinery Institute Head Office: P.O. Box 1900, Humboldt, Saskatchewan, Canada S0K 2A0 Telephone: (306) 682-2555</p>		
<p>3000 College Drive South Lethbridge, Alberta, Canada T1K 1L6 Telephone: (403) 329-1212 FAX: (403) 329-5562 http://www.agric.gov.ab.ca/navigation/engineering/afmrc/index.html</p>	<table style="width: 100%; border: none;"> <tbody> <tr> <td style="width: 50%;"> Test Stations: P.O. Box 1060 Portage la Prairie, Manitoba, Canada R1N 3C5 Telephone: (204) 239-5445 Fax: (204) 239-7124 </td> <td style="width: 50%;"> P.O. Box 1150 Humboldt, Saskatchewan, Canada S0K 2A0 Telephone: (306) 682-5033 Fax: (306) 682-5080 </td> </tr> </tbody> </table>	Test Stations: P.O. Box 1060 Portage la Prairie, Manitoba, Canada R1N 3C5 Telephone: (204) 239-5445 Fax: (204) 239-7124	P.O. Box 1150 Humboldt, Saskatchewan, Canada S0K 2A0 Telephone: (306) 682-5033 Fax: (306) 682-5080
Test Stations: P.O. Box 1060 Portage la Prairie, Manitoba, Canada R1N 3C5 Telephone: (204) 239-5445 Fax: (204) 239-7124	P.O. Box 1150 Humboldt, Saskatchewan, Canada S0K 2A0 Telephone: (306) 682-5033 Fax: (306) 682-5080		