

# Evaluation Report

# 296



## John Shearer Model MK3 Air Seeder

A Co-operative Program Between



# JOHN SHEARER MK3 AIR SEEDER

## MANUFACTURER

John Shearer Limited  
Box 42  
Kilkenny  
South Australia  
5009

**RETAIL PRICE:** (March, 1983, f.o.b. Lethbridge, Alberta).

- a. John Shearer model MK3 air seeder complete with seed boots and distribution system to feed 30 shanks \$28,000.00
- b. Edwards model C\$F-833, 33 ft (9.9 m) heavy duty cultivator \$12,195.00

## DISTRIBUTOR:

Allied Farm Equipment (Canada) Limited 1920 First Avenue Regina, Saskatchewan S4P 3B4

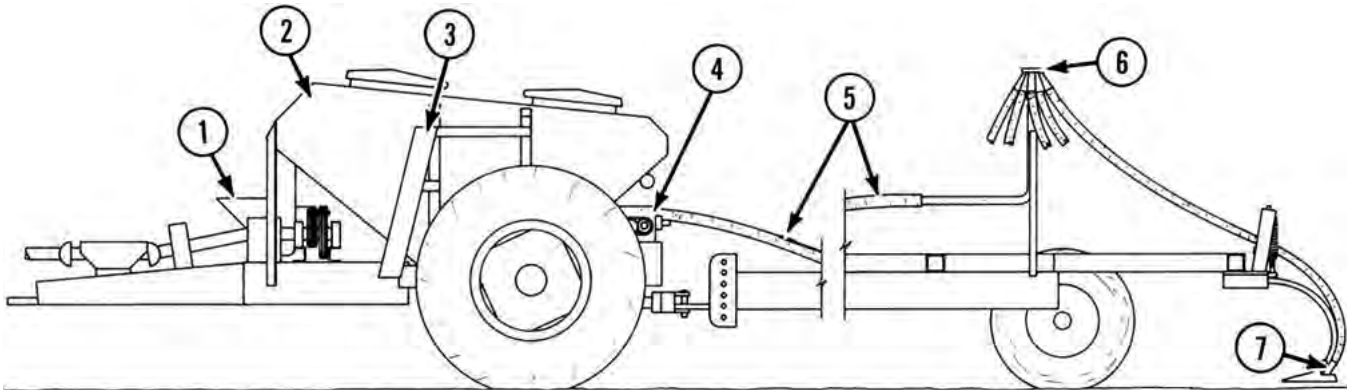

**FIGURE 1.** John Shearer Model MK3 Air Seeder: (1) Fan, (2) Tanks, (3) Tank Access Ladder, (4) Metering System, (5) Primary Distribution Tube, (6) Secondary Header, (7) Seed Boot.

## SUMMARY AND CONCLUSIONS

**Overall Performance:** Performance of the John Shearer model MK3 air seeder was good in all seeding conditions. Performance was good when banding fertilizer. When operated with the 33 ft (9.9 m) Edwards CSF-833 heavy duty cultivator, the John Shearer MK3 was suitable for seeding and fertilizer banding in light primary and secondary field conditions. The John Shearer was suitable for banding fertilizer at application rates up to about 210 lb/ac (236 kg/ha) at 5.5 mph (9 km/h). Higher application rates were possible at reduced speeds. Suitability for seeding and banding fertilizer was reduced in heavy primary tillage due to the light shank spring characteristics of the cultivator. Other heavy duty cultivators, with more rigid shank characteristics, could be used in conjunction with the John Shearer for heavy primary tillage conditions.

**Metering Calibration:** The manufacturer's metering calibrations were fairly accurate in wheat, barley and oats. The manufacturer's calibration was inaccurate in fertilizer. A calibration for canola was not supplied.

**Distribution Uniformity:** Distribution uniformity across the seeding width in wheat, barley, oats and fertilizer was acceptable when seeding using two secondary header outlets per shank. Distribution uniformity was unacceptable in canola using two secondary header outlets per shank. Distribution uniformity in fertilizer, when applied with the seed and using two secondary outlets per shank, was acceptable. When banding fertilizer, using only one secondary header outlet per shank, distribution uniformity was unacceptable at rates above 83 lb/ac (93 kg/ha).

**Effect of Field Variables:** Field bounce, side slope and ground speed had little effect on metering rates. Travelling up or down 10 degree slopes caused up to a 13% change in seeding rate and up to a 9% change in fertilizer rate. Distribution uniformity was only slightly affected by field slope. Grain Damage: Grain damage by the metering and distribution system was within acceptable limits at normal fan speeds.

**Seed Placement and Emergence:** Seed placement was good in most conditions. Variation in seed depth was slightly higher than with a conventional hoe drill when measured in the same fields under the same seeding conditions. Row spacing and seed band width behind each seed boot provided ample stubble for good windrow support. Good cultivator frame levelling was critical to obtain a uniform seeding depth and subsequent good crop emergence.

**Ease of Adjustment and Operation:** Seeding rate within both the high or low metering ranges was easily adjusted. Changing sprockets from high to low range or from low to high range was difficult due to poor access. The need to multiply metering calibration charts by different factors for each sprocket combination was inconvenient. Tank and meter cleanout was inconvenient. Twenty-three grease fittings and two wheel bearings on the applicator required greasing.

Operator visibility of the cultivator was not obstructed by the low profile tanks.

The John Shearer MK3 with Edwards CSF-833 cultivator could be placed in transport position in less than five minutes.

**Rate of Work:** The rate of work usually ranged from 20 to 24 ac/hr (8.1 to 9.7 ha/hr). About 68 ac (27.5 ha) could be seeded before refilling both tanks when seeding wheat at a normal seeding rate. Using only the larger front tank, 39 ac (15.9 ha) could be seeded before refilling.

**Power Requirements:** Tractor size depended on field conditions, seeding depth, ground speed, cultivator width and soil finishing attachments. In light primary tillage, at a 3 in (75 mm) depth and 5 mph (8 km/h), a 139 hp (104 kW) tractor was needed to operate the applicator-cultivator combination. In heavy primary tillage, at the same depth and speed, a 171 hp (128 kW) tractor was needed.

**Safety:** The tank access ladder did not have a safety handrail. The John Shearer MK3 was otherwise safe to operate providing normal safety precautions were observed.

**Operator's Manual:** The operator's manual contained information on assembly, adjustment, operation and maintenance. A detailed parts list was also included. No information on safety was contained in the operator's manual.

**Mechanical Problems:** Only minor mechanical problems occurred during the evaluation. Problems included seed boot bending and wear and a downward shift in meter calibrations from the start to the end of the test.

## RECOMMENDATIONS

It is recommended that the manufacturer consider:

1. Including the seed densities used in preparation of the meter calibration charts.
2. Improving the meter calibration charts for fertilizer.
3. Providing a meter calibration chart for canola.

4. Modifications to the metering rate adjustment assembly so application rates can be changed without requiring sprocket combination changes and metering chart multiplication factors.
5. Modifying the distribution system to improve uniformity in canola.
6. Providing secondary headers with fewer ports to eliminate the need for extensive blocking of secondary outlet ports when banding fertilizer.
7. Supplying a material flow monitoring system as optional equipment.
8. Modifications to the area meter to improve accuracy.
9. Providing a handrail to improve tank access ladder safety.
10. Providing a slow moving vehicle sign on the rear of the applicator as standard equipment.
11. Including information on operator safety in the operator's manual.
12. Providing, as standard equipment, some means of supporting the primary distribution tubes on the cultivator.
13. Modifying the seed boot to increase strength and prevent wear due to soil forces.

Senior Engineer: E. H. Wiens

Project Engineer: R. K. Allam

### THE MANUFACTURER STATES THAT

With regard to recommendation number:

1. The manufacturer agrees that inclusion of density values would be useful to some farm enterprises and it will be incorporated in future calibration charts.
2. The reason for the differences in fertilizer meter calibration charts is felt to be primarily due to differences in the particle size and density of the fertilizer used. Future calibration charts will take these differences into consideration.
3. A calibration chart will be supplied for canola in the future.
4. Modification to the rate adjustment method (i.e. sprocket combination change) is not envisaged. Field information feedback indicates that the sprockets are rarely altered after initial set up. Machines are usually delivered to individual farms, the appropriate sprocket combination for the farms usual seeding rates is selected and in the majority of circumstances the selection is adequate for most seeding rates desired from that point in time forward. Additional calibration charts can be supplied for the 0.43 and 2.3 multiplication factors.
5. An oil seed seeding kit, part numbers 18746 and 18424, has been developed to achieve optimum efficiency and uniformity when metering small seeds such as canola. The kit allows the peg roller distributor to rotate closer to optimum speed while still delivering the reduced quantities required. John Shearer's test with the oil seed seeding kit indicates a coefficient of variation of less than 10% at a seeding rate of 4.5 lb/ac (5 kg/ha) when seeding with one outlet per shank. The cost of this special seeding kit is approximately \$50.00 and has been available for a number of seasons.
6. John Shearer has 5, 6, 8, 9, 10 and 12 outlet secondary distributors available to eliminate the requirement for blocking of outlet ports.
7. Consideration will be given to making flow monitors available as optional equipment.
8. Satisfactory accuracy can be achieved if the correct primary drive sprocket is used.
9. John Shearer agrees with this recommendation and will consider incorporating a handrail into future machines as standard equipment.
10. A slow moving vehicle sign will be provided on future units.
11. The safety section in the operator's manual will be revised and upgraded.
12. An optional kit is available, providing universal standards to support the primary distribution tubes.
13. A steel seeding boot has been recently released to improve operating life expectancy.

### GENERAL DESCRIPTION

The John Shearer model MK3 air seeder is a pneumatic seed and fertilizer applicator designed for use with varying makes and

models of cultivators.

The cultivator is attached to the rear of the applicator with the standard cultivator hitch. The applicator is supported by two wheels, each on single axles.

Seed and fertilizer are pneumatically distributed from two tanks, through a network of tubes to seed boots attached to the rear of each cultivator shank. The applicator can be used for seeding, for combined seed and fertilizer application and for fertilizer banding.

Seed and fertilizer are metered by pegged rollers which rotate inside seed cups mounted below the tanks. Metering rate is controlled by changing sprocket combinations and gear box settings. The metering system is chain driven from the left applicator wheel. The meters are controlled by an electric meter shut-off located in the tractor cab. The tanks are pressurized for positive metering of material. A 1000 rpm power take-off driven fan forces the metered material through the distribution system. The distribution system consists of ten primary tubes, each connected to one of ten sets of pegged metering rollers across the machine width. For the test cultivator, eight of the ten sets of pegged rollers fed eight secondary headers mounted on the cultivator. Seven of the eight sets of pegged rollers contained four rollers, each feeding four cultivator shanks, while the eighth used two pegged rollers feeding only two cultivator shanks. Each John Shearer seed boot required two secondary outlet tubes. Therefore, seven of the secondary headers required eight outlets while one required four outlets. Because 12-port secondary headers were supplied, the extra secondary outlets were blocked off. Each blocked port was adjacent to an open port in a symmetrical pattern.

The test machine was used with an Edwards CSF-833 heavy duty cultivator. This cultivator was 33 ft (9.9 m) wide with a 11.5 ft (3.5 m) centre frame and two 10.5 ft (3.2 m) wing sections. It was equipped with 30 spring cushioned shanks, spaced at 13 in (330 mm), arranged in three rows.

Detailed specifications for the applicator and cultivator are given in APPENDIX I while FIGURE 1 shows the location of major components.

### SCOPE OF TEST

The John Shearer model MK3 air seeder was operated in loam and clay soils in the field conditions shown in TABLE 1 for approximately 120 hours while processing about 1610 ac (652 ha). It was evaluated for quality and rate of work, ease of operation and adjustment, power requirements, safety and suitability of the operator's manual.

TABLE 1. Operating Conditions

CROP	FIELD TILLAGE CONDITIONS	STONE CONDITIONS	FIELD AREA		HOURS
			ac	ha	
Spring wheat on stubble	Primary	Occasional stones	380	155	28
Spring wheat on summerfallow	Secondary	Occasional stones	50	20	4
Spring wheat on summerfallow	Secondary	Moderately stony	200	81	15
Durum wheat on stubble	Secondary	Occasional stones	230	93	17
Barley on summerfallow	Primary	Moderately stony	180	73	13
Barley on summerfallow	Secondary	Very stony	40	16	3
Winter wheat on stubble	Secondary	Stone free	60	20	4
Banding fertilizer	Primary	Occasional stones	480	194	30
TOTAL			1610	652	120

### RESULTS AND DISCUSSION

#### QUALITY OF WORK

**Metering Accuracy:** The grain and fertilizer metering system was calibrated in the laboratory<sup>1</sup> and compared with the manufacturer's calibration. Since actual seeding rates for certain settings depended on things such as seed size, density and moisture content, it is not possible for a manufacturer to present charts to include all the varieties of seed. Field calibration checks may be necessary for seed with properties differing from those used in establishing the manufacturer's charts. Research has, however, shown that small variations in seeding rates will not significantly affect grain crop yields.

<sup>1</sup>Detailed Test Procedures for Air Seeders.

Primary meter drive sprockets for the John Shearer MK3 were available in sizes ranging from 18 to 33 teeth. A 19-tooth primary sprocket was supplied for the evaluation.

A high or low metering range could be selected by changing sprocket combinations. In high range a multiplication factor of 1 was applied to the metering calibration charts and in low range a factor of 0.43 was applied to the calibration charts. For higher rear tank metering rates, alternate external gears were used on the gearbox, which required applying a factor of 2.3 to the calibration charts.

The requirement for sprocket changes to obtain the various seeding rate ranges was inconvenient. The need to multiply metering calibration charts by different factors for each sprocket combination was also inconvenient for quick and easy field use. It is recommended that the manufacturer consider modifications to the metering rate adjustment assembly so application rates can be changed without requiring sprocket combination changes and metering chart multiplication factors.

The clearance between the pegged metering rollers and the seed cups could be adjusted in one of four gate settings to suit seed size. A gate setting of 1 was used for small grains such as canola while a gate setting of 2 was used for cereal grains and fertilizers.

The seed densities used by the manufacturer for meter calibration were not given. It is recommended that they be included to permit the operator to compare seed densities to determine if field meter calibrations are necessary.

Calibration curves for wheat, barley, oats and fertilizer are given in FIGURES 2 to 5. PAMI's calibration curves are compared to the manufacturer's calibration curves. At a seeding rate of 70 lb/ac (79 kg/ha), PAMI's measured rates were 10% lower than the manufacturer's calibration in wheat, 13% lower than the manufacturer's calibration in barley, and 11% lower than the manufacturer's calibration in oats. At an application rate of 38 lb/ac (42 kg/ha), PAMI's measured rate in 11-51-00 fertilizer was 32% lower than the manufacturer's indicated rate while at an application rate of 393 lb/ac (440 kg/ha), PAMI's measured rate was 40% lower than the manufacturer's indicated rate. It is recommended the manufacturer consider improving the accuracy of the calibration charts for fertilizer.

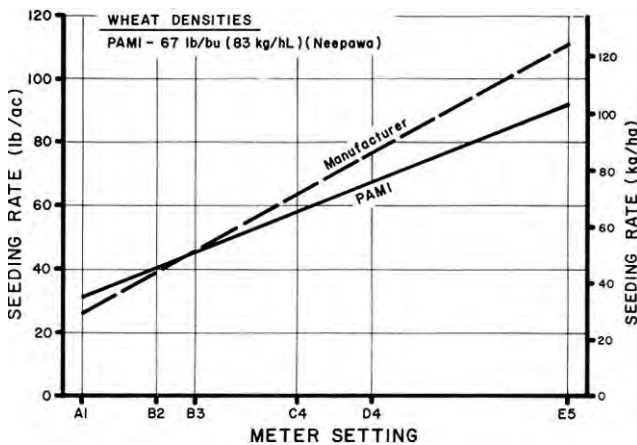

FIGURE 2. Metering Accuracy in Wheat Using a Calibration Chart Multiplication Factor of 1.

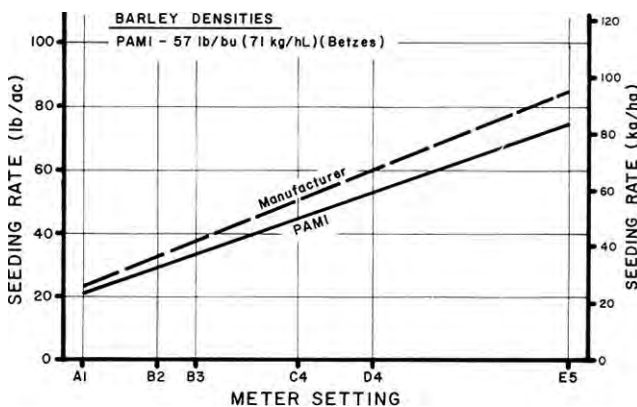

FIGURE 3. Metering Accuracy in Barley Using a Calibration Chart Multiplication Factor of 1.

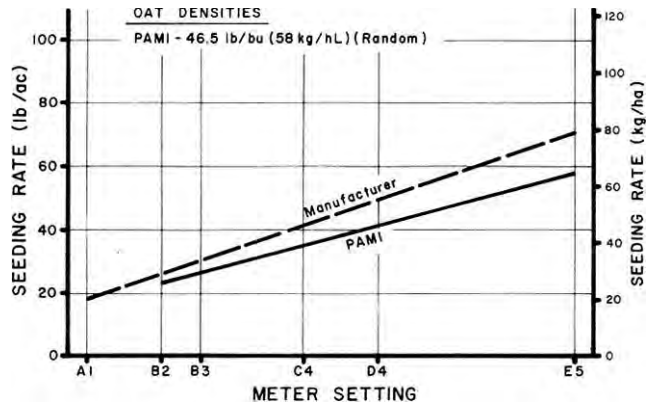

FIGURE 4. Metering Accuracy in Oats Using a Calibration Chart Multiplication Factor of 1.

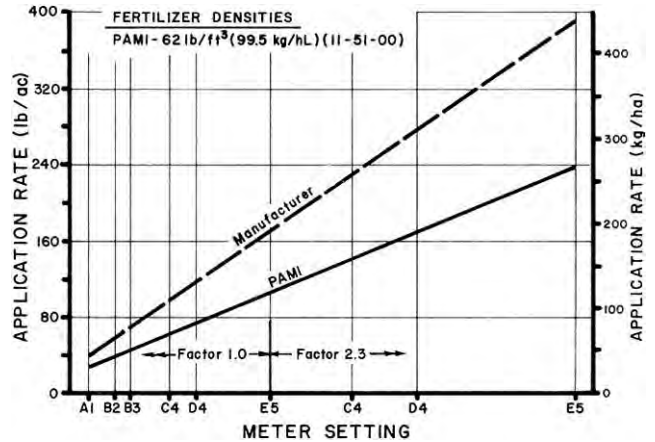

FIGURE 5. Metering Accuracy in Fertilizer Using a Calibration Chart Multiplication Factor of 1 and 2.3.

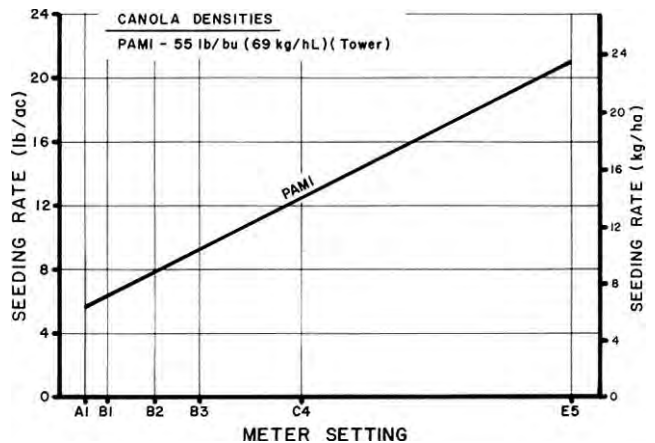

FIGURE 6. PAMI's Meter Calibration Curve in Canola Using the Low Range Sprocket Combination.

No manufacturer's calibration curve was supplied for canola. PAMI's calibration curve for canola is given in FIGURE 6. It is recommended that the manufacturer consider supplying a meter calibration curve for canola.

Machine and field variables such as field bounce, side slope and ground speed had little effect on metering rates. When travelling up and down hills, effects on the front and rear metering systems were opposite. For example, travelling up a 10 degree slope increased the front meter application rate up to 13% in wheat and 8% in fertilizer. It decreased the rear meter application rate up to 6% in wheat and 9% in fertilizer. Travelling down a 10 degree slope decreased the front meter application rate up to 6% in wheat and 9% in fertilizer while increasing the rear meter application rate by

\*The coefficient of variation (CV) is the standard deviation of seeding rates from individual shanks expressed as a percent of the average seeding rate. An accepted variation for seeding grain or applying fertilizer is a CV value not greater than 15%. If the CV is less than 15%, distribution is acceptably uniform, whereas if the CV is greater than 15%, the variation in application rate among individual shanks is excessive.

up to 13% in wheat and 8% in fertilizer. Although wheel slippage in most fields is common with many ground driven applicators, no ground drive wheel slippage of the large diameter drive wheel was experienced with the John Shearer MK3.

**Distribution Uniformity:** FIGURE 7 gives seeding distribution uniformity for the John Shearer MK3 in wheat, barley and oats. Distribution was uniform over the full range of seeding rates for wheat, barley and oats. For example, at a seeding rate of 75 lb/ac (85 kg/ha) the coefficient of variation<sup>2</sup> (CV) was 10% for wheat and 8.0% for barley. At a seeding rate of 50 lb/ac (55 kg/ha) for oats, the CV was 9.5%. FIGURE 8 shows a typical seed distribution pattern obtained in wheat at a seeding rate of 68 lb/ac (76 kg/ha). The application rate from each shank across the width of the air seeder varied from 57 to 85 lb/ac (64 to 95 kg/ha). This resulted in an acceptable distribution uniformity with a CV of 10%.

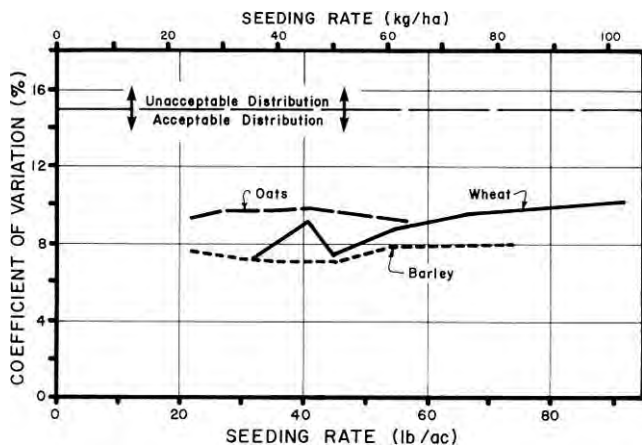

FIGURE 7. Distribution Uniformity in Cereal Grains Over a Range of Seeding Rates at 5.5 mph (9 km/h).

FIGURE 9 shows a typical distribution pattern obtained in canola at a seeding rate of 8 lb/ac (9 kg/ha). The application rate across the width of the air seeder varied from 6 to 12 lb/ac (7 to 13 kg/ha), which resulted in unacceptable distribution uniformity with a CV of 21%. Although distribution uniformity in canola improved at higher application rates, canola distribution uniformity was unacceptable over the full range of seeding rates (FIGURE 10). It is recommended that the manufacturer consider modifications to the distribution system to improve distribution in canola.

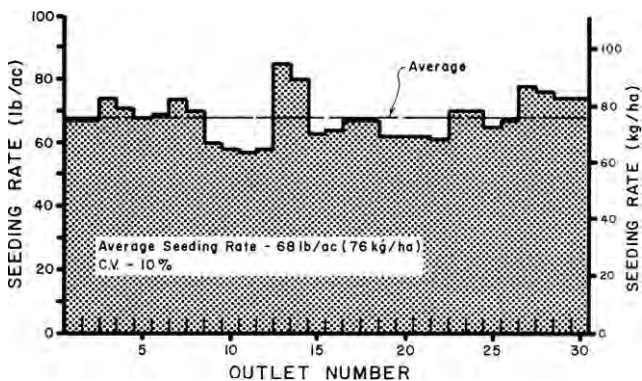

FIGURE 8. Distribution Uniformity Pattern in Wheat at 68 lb/ac (76 kg/ha).

Distribution uniformity in 11-51-00 fertilizer depended on the number of outlets used per cultivator shank. FIGURE 11 indicates an acceptable distribution uniformity obtained with fertilizer when using the normal two outlets per shank when applying fertilizer with the seed. When banding fertilizer, only one outlet per shank could be used so the fertilizer could be placed in the required narrow band. Unacceptable distribution uniformity resulted with fertilizer at rates above 83 lb/ac (903 kg/ha) when using only one outlet per shank. The difference in uniformity was due to the need to block 8 of the 12 outlets on each secondary header when using only one outlet per shank. It is recommended that the manufacturer consider supplying secondary headers with fewer outlet ports to eliminate the need for extensive blocking of outlet ports when banding fertilizer.

Changes in distribution pattern uniformity could occur at different forward speeds or for different machine widths due to different volumes of material being introduced into the constant volume of air supplied by the fan.

Changes in fan speed and operation in hilly terrain had only a small effect on distribution pattern uniformity.

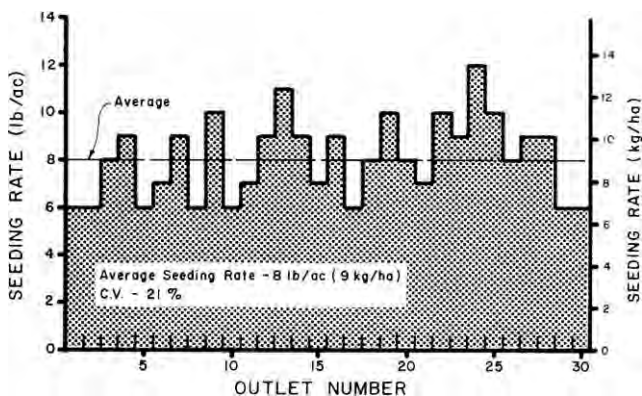

FIGURE 9. Distribution Uniformity Pattern in Canola at 8 lb/ac (9 kg/ha).

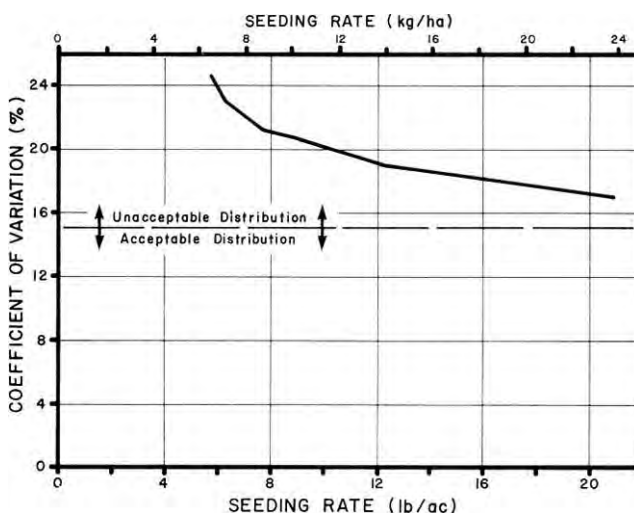

FIGURE 10. Distribution Uniformity in Canola Over a Range of Seeding Rates at 5.5 mph (9 km/h).

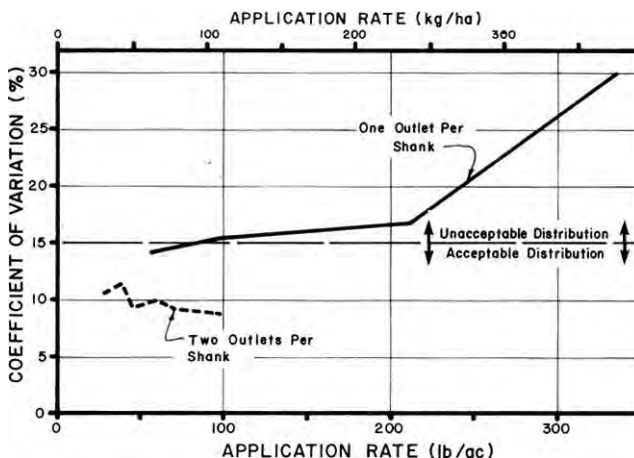

FIGURE 11. Distribution Uniformity in Fertilizer Over a Range of Application Rates at 5.5 mph (9 km/h).

**Grain Damage:** Grain damage by the metering and distribution system was within acceptable limits for cereal grains and canola at the normal fan speed of 5400 rpm. For example, in dry Neepawa wheat at 11% moisture content, only 0.1% cragage occurred. In dry canola with a moisture content of 7%, 1.4% cragage occurred.

**Seed Placement:** Each seed boot used two secondary outlet tubes per opener (FIGURE 12). A V-shaped spreader was located at the base of the seed boot to effectively spread the seed behind each sweep. Although rows were visible when grain first emerged, in most

fields, after complete crop emergence, it was difficult to observe distinct plant rows. Therefore, even with 13 in (330 mm) cultivator shank spacing there was sufficient stubble for windrow support at harvest time (FIGURE 13).

Variation in seed depth depended on field tillage conditions. Although seed placement was adequate in all secondary and light primary field conditions, the shanks on the Edwards CSF-833 cultivator were not sufficiently rigid to maintain a uniform sweep pitch throughout the full range of soil forces encountered in all primary soil conditions (FIGURE 15). Other cultivators with more rigid shank characteristics could be used in conjunction with the John Shearer to overcome this problem.

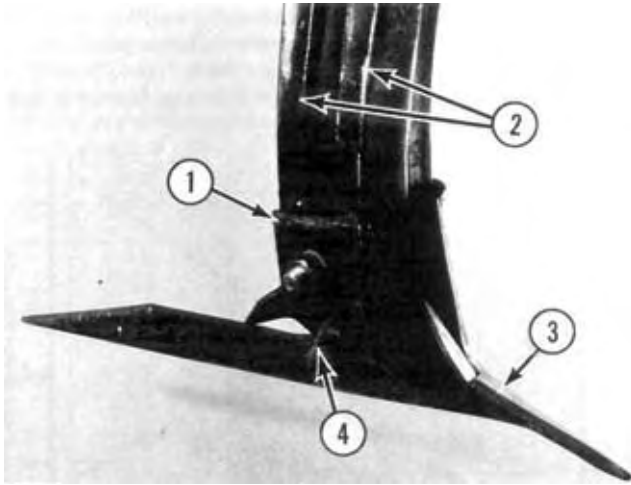

**FIGURE 12.** John Shearer Seed Boot: (1) Seed Boot, (2) Secondary Outlet Tubes, (3) Sweep, (4) V-shaped Spreader.

Although seeds were usually placed on the furrow bottom at the working depth of each individual cultivator sweep, depth across the width of the machine varied due to cultivator frame geometry and non-uniform field surfaces. On level and gently rolling fields, in light primary or secondary field conditions, seed depth was quite uniform. For example, at an average seeding depth of 2.4 in (60 mm), seeding depth across the width of machine varied from 1.2 to 3.7 in (30 to 95 mm) with most of the seeds being placed within 0.7 in (18 mm) of the average cultivator sweep working depth. This compares to seed being placed from 0.5 to 0.6 in (12 to 15 mm) from average seeding depth for a hoe drill in similar conditions.

In fields with sharp hill crests or gullies, seed depth variation became much greater than for a hoe drill due to the greater distances between shank rows on a heavy duty cultivator than on a hoe drill.

In heavy primary tillage conditions, seed depth variation increased due to draft forces exceeding the shank spring preload setting. Therefore, seeding in heavy primary tillage conditions using an air seeder and the Edwards CSF-833 cultivator is not recommended.

**Plant Emergence:** As with most seeding implements, time and uniformity of plant emergence depended on seedbed preparation, soil moisture and seed placement. The John Shearer MK3 was used to seed in a number of fields with different types of seedbed preparation. Uniform emergence resulted as long as machine settings were carefully adjusted to place seed in moist soil at the correct depth and providing loose seedbeds were packed after seeding. FIGURE 13 shows good emergence when spring wheat was seeded into pre-worked stubble.

Careful cultivator frame levelling was important in obtaining uniform emergence across the cultivator width. Due to the rigidity of heavy duty cultivator frames, improper sideways levelling and fore-and-aft levelling can both result in rows of shanks operating at different depths.

**Seeding Depth:** It is very important to seed at the correct depth to obtain uniform seed coverage. Correct cultivator adjustments for pneumatic seeding were best obtained by comparing the depth of seeds placed by several shanks across the cultivator width and from both the front and rear shank rows. This permitted accurate frame levelling to obtain uniform seed coverage. Seeding shallower than 2 in (50 mm) is not recommended for a heavy duty cultivator, due

to poor seed coverage and generally poor cultivator performance at shallow tillage depths.

Frame levelling had to be checked and appropriate depth adjustments made when changing fields to ensure adequate, uniform seed coverage.



**FIGURE 13.** Uniform Wheat Emergence in Pre-worked Stubble. (Upper: 28 Days After Seeding, Lower: At Harvest.)

**Soil Finishing:** The John Shearer MK3 with Edwards cultivator was not equipped with packers. Since it was considered essential to pack most fields seeded with the John Shearer, a harrow-packer drawbar equipped with five bar tine harrows and trailing steel coil packers<sup>3</sup> was used as a follow-up operation.

The harrow-packer combination served to smooth and pack the seedbed, leaving packer ridges from 1.0 to 1.2 in (25 to 30 mm). To obtain a smooth, firm seedbed in dry conditions required packer-drawbar operations in two directions. Care had to be used in moist conditions to avoid over-packing the seedbed. FIGURE 14 shows a typical seedbed after seeding into stubble, both before and after use of the harrow-packer drawbar.

**Shank Characteristics:** The Edwards CSF-833 heavy duty cultivator was equipped with adjustable, spring cushioned shank holders. During the evaluation it was used with 16 in (105 mm) wide Edwards sweeps with 50 degree stem angles, giving a no-load sweep pitch of 5 degrees. Sweep pitch (FIGURE 15) varied 2.5 degrees over the range of draft (drawbar pull) normally encountered in secondary tillage conditions.

Cushioning spring preload was exceeded at drafts greater than 275 lb/ft (4 kN/m), occurring in the lower portion of the range of normal primary tillage. This shows that the Edwards CSF-833 cultivator was suitable only for secondary tillage and light primary tillage. In heavy, primary tillage, sweep pitch became excessive, resulting in non-uniform seeding depth and furrow bottom ridging.

**Penetration:** When equipped with 50 degree, 16 in (406 mm) sweeps, penetration was very good in secondary and light primary tillage and it was easy to obtain correct seeding depth. However, due to increased sweep pitch at higher draft, use of the Edwards CSF-833 cultivator is not recommended for heavy primary tillage. Penetration was uniform across the cultivator width provided all depth control linkages and hitch height were kept properly adjusted.

The cultivator wheels were positioned so that each centre section wheel supported about 16% of the total cultivator weight and each wing wheel supported about 8%. In addition, each set of dual wheels supported about 25% of the total tillage suction force. Cultivator or air seeder sinking was not a problem in moderately soft soils. Since the pneumatic seeder was not supported by the cultivator wheels but was carried on its own wheels, it did not contribute to cultivator sinking in soft soils.

<sup>3</sup>See PAMI Evaluation Reports 277 and 304.

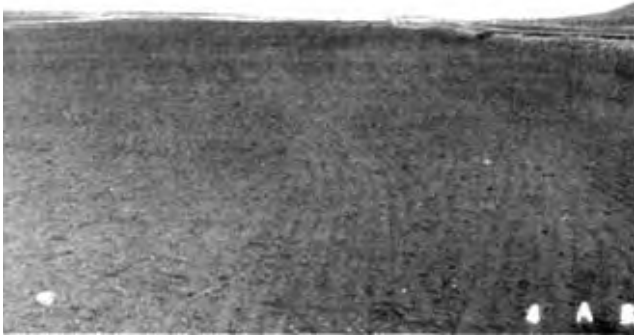

FIGURE 14. Typical Seedbed. (Upper: Before Packing, Lower: After Packing.)

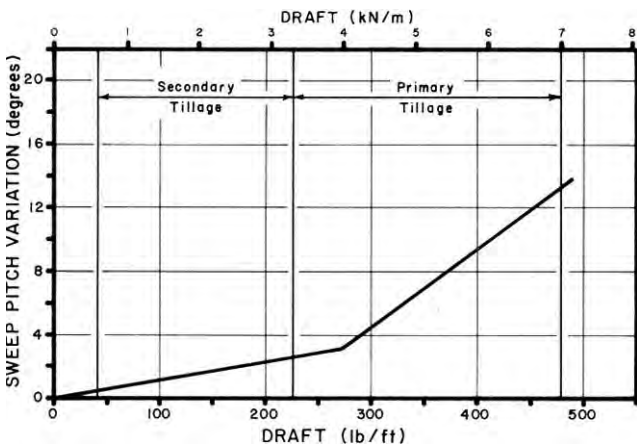

FIGURE 15. Sweep Pitch Variation over a Normal Range of Draft with 13 in (330 mm) Shank Spacing.

**Trash Clearance:** Trash clearance with the Edwards CSF-833 cultivator was very good in most conditions. With 16 in (406 mm) sweeps it was possible to operate in fields with a heavier trash cover than was possible with a conventional hoe drill.

**Skewing and Stability:** The John Shearer MK3 seeder with Edwards CSF-833 cultivator was very stable and sideways skewing occurred only in very hilly conditions. The cultivator shank pattern was symmetrical and did not impose any side forces on the cultivator during normal tillage. When equipped with 16 in (406 mm) sweeps, the cultivator had to skew more than 2.6 degrees to miss weeds. Throughout the evaluation period, in normal seeding conditions, skewing was never serious enough to cause weeds to be missed.

**Weed Kill:** Weed kill was very good when equipped with 16 in (406 mm) sweeps. The 13 in (330 mm) shank spacing resulted in 3 in (76 mm) sweep overlap. Considerable sweep wear could occur before weeds were missed. However, to ensure adequate sweep lift is maintained for proper seed placement, sweeps should be replaced before significant wear is evident.

**Fertilizer Banding:** The John Shearer MK3 could be used for two types of fertilizer applications. It could be used for normal fertilizer application at seeding time by metering fertilizer from one tank and grain from the other and applying both through the same seed boots. When equipped with chisel points, and alternate banding boots (FIGURE 16), it could also be used for fertilizer banding.

Banding is a relatively new method of fertilizer application

on the prairies. Experimental results suggest that placing fertilizer in compact bands from 1.5 in (35 mm) below seed depth to twice seeding depth is desirable for fall fertilizer application. This requires the use of chisel points to obtain sufficient depth and minimize soil disturbance and special boots to minimize fertilizer spreading. In order to place the fertilizer in the required narrow band, it was necessary to block eight out of 12 ports on each secondary header so only a single outlet per cultivator shank was being used.

The John Shearer MK3 worked well for fertilizer banding. Fertilizer granules were placed in a band about 1 in (25 mm) wide. Vertical fertilizer distribution generally ranged from chisel tip depth to 0.4 in (10 mm) above chisel tip depth. Wider fertilizer bands were obtained in lumpy soil conditions and as the chisel points became worn.

Each metering system, in high range with the standard external gears, could deliver fertilizer application rates up to 100 lb/ac (112 kg/ha) for a total application rate of 200 lb/ac (224 kg/ha). If higher banding rates were required an alternate external gear set could be used which allowed rear tank metering rates up to 236 lb/ac (265 kg/ha). The fan provided adequate air for the 33 ft (9.9 m) cultivator, to allow distribution of 100 lb/ac (112 kg/ha) from the front meter and 236 lb/ac (265 kg/ha) from the rear meter. This resulted in a maximum application rate of 336 lb/ac (377 kg/ha).

The single outlet per shank requirement of the John Shearer banding boot and subsequent blocking of secondary header ports affected the distribution uniformity characteristics significantly.

FIGURE 11 shows distribution uniformity in 11-51-00 fertilizer, both with two outlets per shank when seeding and with one outlet per shank as used when banding fertilizer. When using two outlets per shank at the rate of 100 lb/ac (112 kg/ha), uniformity was acceptable with a CV of 9%. When using one outlet per shank, uniformity at this rate was unacceptable with a CV of 15.5%. This significant difference in uniformity was attributed to the extensive blocking of secondary headers required when using one outlet per shank. As already discussed, 8 of the 12 header ports were blocked when banding fertilizer. At banding rates above 210 lb/ac (236 kg/ha), distribution uniformity deteriorated rapidly and reduced the suitability of the John Shearer MK3 for banding at higher application rates. It has already been recommended that the manufacturer consider supplying secondary headers with fewer ports to eliminate the need for extensive blocking of ports when banding fertilizer.

The John Shearer MK3 tanks and metering system were sealed against moisture entry. This eliminated fertilizer caking problems due to rainfall. All unprotected metal surfaces should be cleaned and oiled periodically when applying fertilizer to prevent corrosion.

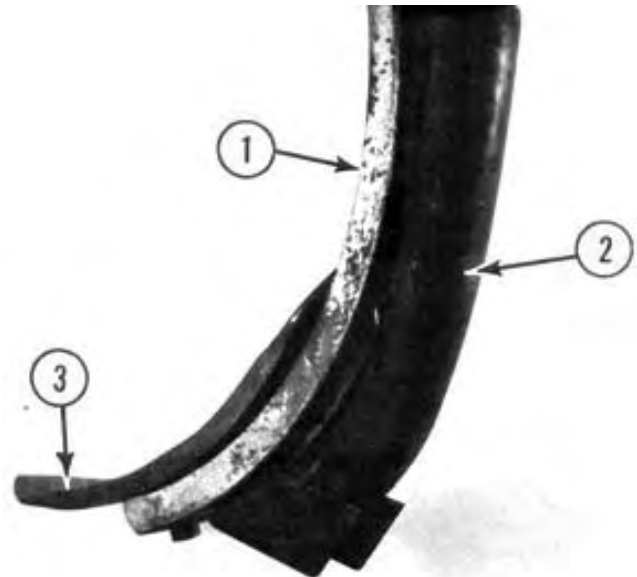

FIGURE 16. John Shearer Banding Boot: (1) Cultivator Shank, (2) Banding Boot, (3) Chisel Point.

#### EASE OF OPERATION

**Dual Purpose Operation:** The John Shearer MK3 could be detached from the cultivator by two men in about one hour. The

secondary headers and hoses had to be removed from the cultivator, allowing the cultivator to be used as a dual purpose machine, both for seeding and seasonal tillage.

**Hitching:** The John Shearer MK3 was easily hitched to a tractor. Hitching convenience was increased by the fact that the hitch link remained horizontal when unhitched from the tractor. Hitching also required hook-up of four hydraulic lines with quick couplers and an electrical connector for the electronic monitoring system.

**Filling:** A drill fill or grain auger was needed to conveniently fill the applicator tanks. Because the filler openings were located only 5.6 ft (1.7 m) above the ground, hand filling was also possible. The large 1.5 x 8.8 ft (0.5 x 2.7 m) filler openings gave ample room for auger filling. The filler lids were mounted on hinges and were easily lifted. The lids were latched with a simple lever. The lids were equipped with weather stripping for an airtight and moisture tight seal.

The front tank held 50 bu (1818 L) while the rear tank held 37 bu (1346 L).

**Visibility:** Visibility of the cultivator was unobstructed by the low profile applicator. This was considered a desirable feature of the John Shearer MK3.

**Maneuverability:** Because of the additional pivot point at the hitch between the applicator and cultivator, the John Shearer MK3, when attached to the cultivator, was difficult to manoeuvre while backing up.

**Monitoring:** The John Shearer was equipped with an electronic monitoring system which monitored meter operation, fan speed and tank level. When the metering shafts stopped rotating, fan speed became too high or low, or tank level dropped to near empty, respective warning lights flashed and a warning beep was emitted. Also included was an electronic on-off switch for meter shut-off and a digital readout for area covered.

Material flow through the distribution tubes was not monitored. Because plugging of the distribution system was difficult to detect from the tractor seat, it is recommended that a flow monitoring system be made available as optional equipment.

**Seed and Fertilizer Boots:** One seed boot plugged with a lump of soil while seeding. No fertilizer boot plugging problems were encountered while banding fertilizer.

**Cleaning:** Access to the discharge side of the pegged metering rollers was possible with full tanks by opening two access doors under the meters. Opening these doors required unlocking six hand operated fasteners.

Small cleanout doors were provided on both sides of each tank. Use of these cleanout doors was inconvenient since all of the material would not empty without moving the grain to the doors. A vacuum cleaner was required for thorough cleaning of both tanks. Access to the tanks was possible through the filler openings.

**Area Meter:** The John Shearer MK3 was equipped with an electronic area meter. The meter was calibrated in hectares and read 19% high when used with the 19 tooth primary drive sprocket supplied and the 33 ft (9.9 m) cultivator. The area meter circuitry could not be easily adjusted to suit the width of the implement other than by changing the primary drive sprocket. It is recommended that the manufacturer consider modifications to the area meter to improve accuracy.

**Transporting:** A distinct advantage of cultivator mounted air seeders over conventional drills, is the ease with which relatively wide machines can be transported. The John Shearer MK3 applicator with Edwards cultivator was easily placed in transport position (FIGURE 17) in less than five minutes. Two hydraulic cylinders raised the cultivator wings to the upright position. The metering system was conveniently engaged and disengaged with an electrically operated lockout, controlled from the tractor seat. For long distance travel at high speeds, the meter drive chain should be removed. This procedure was somewhat inconvenient due to poor access to the drive chain behind the meter drive chain safety shield.

The assembly towed well in transport position. Overall transport height and width were 12.8 ft (3.9 m) and 19.0 ft (5.8 m) respectively, requiring care when transporting on public roads.

## EASE OF ADJUSTMENT

**Lubrication:** Lubrication was convenient with good access to all grease fittings. Twenty-three fittings on the applicator and none on the cultivator required servicing. Two wheels on the applicator

and eight on the cultivator required servicing. A servicing schedule was supplied in the operator's manual.

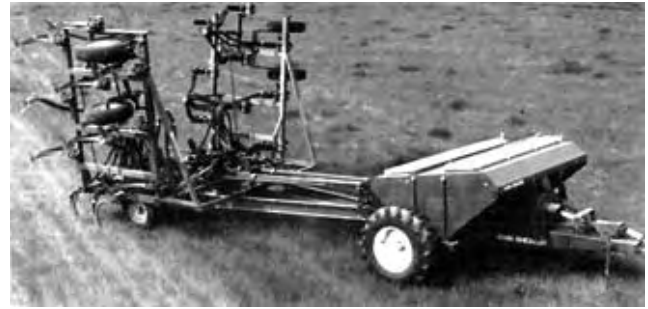

FIGURE 17. Transport Position.

**Application Rate:** Application rate was changed by adjusting the gear box settings for seed and fertilizer as shown in FIGURE 18. There were 21 possible gear box settings. A low range for small seeds such as canola was obtained by interchanging two sets of sprockets. Changing the high-low range sprockets was difficult due to poor access. An additional high range could also be obtained by installing alternate external gears on the gearbox. Calibration charts, in kilograms per hectare, were shown in both the operator's manual and on a decal on the air seeder. The manufacturer's calibrations had to be multiplied by conversion factors to suit the width of machine, sprockets used, and the number of pegged roller sets used. It has already been recommended that the manufacturer consider modifications to simplify metering rate adjustments.

The gearbox settings allowed relatively precise seeding rate adjustment. For example, in Tower canola, each gearbox setting changed seeding rate by about 0.6 lb/ac (0.7 kg/ha).

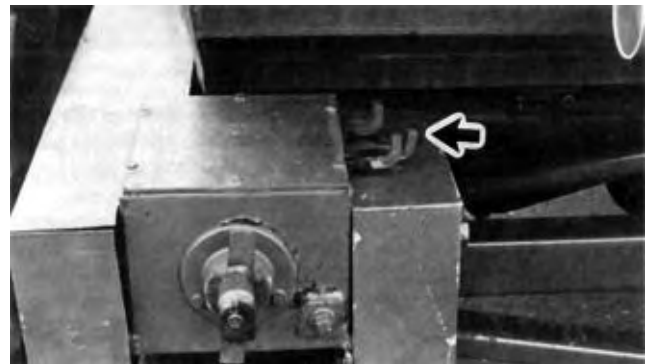

FIGURE 18. Application Rate Adjustment.

**Depth Adjustment:** Seeding depth was conveniently adjusted with a single hydraulic cylinder. Each set of dual wheels on the cultivator was linked to the depth control cylinder with chains and connector links. An adjustable, hydraulic depth stop was used to set maximum depth.

The frame was levelled by positioning the hitch link in one of five positions and by adjusting a threaded connector bolt on each dual wheel depth control linkage. Repositioning the hitch link required the use of wrenches. Cultivator levelling adjustments were adequate to suit all field conditions encountered throughout the evaluation.

## RATE OF WORK

The John Shearer MK3 was operated at speeds from 3 to 6 mph (5 to 10 km/h). Overall best performance, in terms of weed kill and seed placement, was obtained at speeds of 5 to 6 mph (8 to 10 km/h). This resulted in field work rates for the 33 ft (9.9 m) unit ranging from 20 to 24 ac/hr (8.1 to 9.7 ha/h). Using both tanks when seeding wheat at a rate of 75 lb/ac (85 kg/ha), about 68 ac (27.5 ha) could be seeded before refilling. Using only the larger front tank, about 39 ac (15.9 ha) could be seeded before refilling. This compares to 37 to 56 ac (15 to 23 ha) between refills for most conventional drills of similar widths.

## POWER REQUIREMENTS

**Fan:** The power requirement of the John Shearer MK3 fan, operating at the recommended power take-off speed of 1000 rpm



and fan speed of 5400 rpm, was 5.9 hp (4.3 kW).

**Draft Requirements:** Attempting to compare draft (drawbar pull) requirements of different makes of heavy duty cultivators usually is unrealistic. Draft requirements for the same cultivator, in the same field, may vary by as much as 30% in two different years, due to changes in soil conditions. Variation in soil conditions affect draft much more than variation in machine make, usually making it impossible to measure any significant draft difference between makes of heavy duty cultivators. The power requirements given in TABLES 2 and 3 are based on average draft requirements of 15 makes of heavy duty cultivators in 56 different field conditions. Additional draft due to the John Shearer MK3 applicator with full tanks and power requirements of the power take-off driven fan has been included.

**Tractor Size:** TABLES 2 and 3 show tractor sizes needed to operate the John Shearer MK3 applicator, with the 33 ft (9.9 m) Edwards CSF-833 heavy duty cultivator, in light and heavy primary tillage. Tractor sizes have been adjusted to include tractive efficiency and represent a tractor operating at 80% of maximum power on a level field. The sizes presented in the tables are the maximum power take-off rating as determined by Nebraska tests or as presented by the tractor manufacturer. Selected tractor sizes will have ample power reserve to operate in the stated conditions.

Tractor size may be determined by selecting the desired tillage depth and speed from the appropriate table. For example, in light primary tillage at a 3 in (75 mm) depth and 5 mph (8 km/h), a 139 hp (104 kW) tractor is required to operate the seeding unit. In heavy tillage at the same depth and speed a 171 hp (128 kW) tractor is needed. Power tests with cultivators equipped with chisel points indicated that tractors suited for seeding in heavy primary tillage conditions will have ample power for banding fertilizer at depths up to 2 in (50 mm) greater than seeding depth.

**TABLE 2.** Tractor Size (Maximum Power Take-off Rating, hp (kW)) to Operate the John Shearer MK3, with 33 ft (9.9 m) Edwards CSF-833 Cultivator in Light Primary Tillage.

DEPTH in (mm)	SPEED mph (km/h)			
	4 (6.4)	5 (8)	6 (9.6)	7 (11.2)
2 (50)	78 (58)	104 (78)	133 (58)	165 (123)
3 (75)	107 (80)	139 (104)	176 (80)	215 (160)
4 (102)	135 (101)	175 (131)	218 (101)	264 (197)
5 (127)	163 (122)	211 (157)	261 (122)	314 (234)

**TABLE 3.** Tractor Size (Maximum Power Take-off Rating, hp (kW)) to Operate the John Shearer MK3, with 33 ft (9.9 m) Edwards CSF-833 Cultivator in Heavy Primary Tillage.

DEPTH in (mm)	SPEED mph (km/h)			
	4 (6.4)	5 (8)	6 (9.6)	7 (11.2)
2 (50)	75 (56)	99 (74)	115 (86)	143 (107)
3 (75)	132 (98)	171 (128)	201 (150)	244 (182)
4 (102)	190 (142)	243 (181)	288 (215)	345 (257)
5 (127)	248 (185)	316 (236)	374 (279)	446 (333)

## OPERATOR SAFETY

Although the ladder provided convenient access to the tank openings, caution had to be used. The tank access ladder did not have a handrail for the operator to hold on to while climbing or descending. A handrail would also improve safety when stepping from the tank walkway to the small ladder platform, located at the top of the ladder (FIGURE 19). It is recommended that the manufacturer consider providing a handrail to improve tank access ladder safety.

Extreme caution is needed in transporting most folding cultivators, to avoid contacting power lines. Minimum power line heights vary in the three prairie provinces. In Saskatchewan, the energized line may be as low as 17 ft (5.2 m) over farm land or over secondary roads. In Alberta and Manitoba, the neutral ground wire may be as low as 15.7 ft (4.8 m) over farm land. In all three provinces, power lines in farmyards may be as low as 15 ft (4.6 m).

Transport height of the 33 ft (9.9 m) wide test machine was 12.8 ft (3.9 m), permitting safe transport under prairie power lines. On the other hand, wider models of cultivators are high enough to contact some prairie power lines. The legal responsibility for safe passage under utility lines rests with the machinery operator and not with the power utility or the machinery manufacturer. All provinces have regulations governing maximum permissible equipment heights on various types of public roads. If height limits are exceeded, the

operator must contact power and telephone utilities before moving. The test machine was 19 ft (5.8 m) wide in transport position, necessitating caution when towing on public roads, over bridges and through gates.

Mechanical wing and depth control transport locks were provided. No slow moving vehicle sign or mounting bracket was provided with the John Shearer MK3. It is recommended that a slow moving vehicle sign be supplied as standard equipment.

The John Shearer MK3 applicator with Edwards CSF-833 cultivator towed well at speeds up to 17 mph (28 km/h).



**FIGURE 19.** Tank Access Ladder.

## OPERATOR'S MANUAL

The operator's manual supplied with the John Shearer MK3 contained useful information on assembly, operation, maintenance and adjustments. A detailed parts list and a section on trouble shooting was also included. Calibration charts, in kilograms per hectare, were included in the operator's manual and on a decal on the machine. No information on operator safety was included. It is recommended that information on operator safety be included in the operator's manual.

## DURABILITY RESULTS

TABLE 4 outlines the mechanical history of the John Shearer MK3 air seeder with Edwards CSF-833 cultivator during 120 hours of field operation while processing about 1610 ac (652 ha). The intent of the test was evaluation of functional performance. An extended durability evaluation was not conducted.

**TABLE 4.** Mechanical History.

ITEM	OPERATING HOURS	EQUIVALENT FIELD AREA ac (ha)
<b>APPLICATOR</b>		
-Six brackets were fabricated for supporting the primary distribution tubes at	beginning of test	
-A magnetic pick-up for monitoring meter shaft rotation was adjusted and tightened at	8	100 (71)
-The snap ring holding the meter drive sprocket fell off and was replaced at	13	175 (71)
-The seed boots were worn and a number of seed boots bent and broke	throughout the test	
-One seed boot plugged above the V-shaped deflector with a soil lump at	46	620 (251)
-Two secondary header support bolts broke off allowing the header to tip over at	50	670 (271)
-Two rear drawbar bolts loosened and were tightened at	50	670 (271)
-The meter drive chain was tightened at	52	700 (283)
-A small amount of metered material collected on the lower meter access doors	throughout the test	
-The metering rate calibrations shifted by about 10 per cent	during the test	
<b>CULTIVATOR</b>		
-One shovel broke at	52	700 (283)
-All the sweeps were replaced at	80	1070 (433)
-Fertilizer banding boots and chisel points were installed at	84	1130 (457)
-The cultivator depth control adjustments loosened due to field vibration	throughout the test	

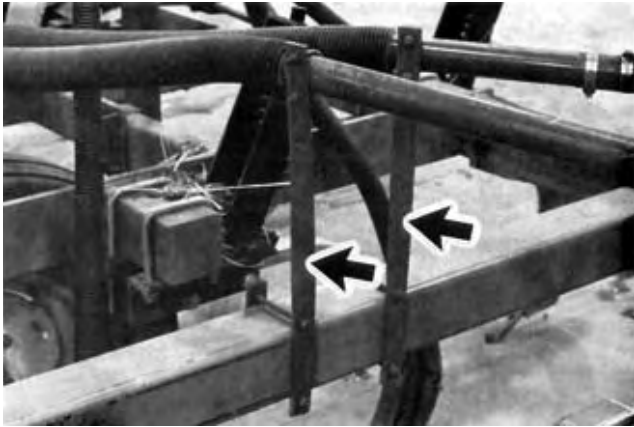

FIGURE 20. Fabricated Primary Distribution Tube Support Brackets.

**Seed Boots:** The V-shaped deflector located at the base of the John Shearer seed boot was exposed to soil forces below the cultivator sweep. After a short period of time all seed boots showed visible wear and bending due to this exposure.

Due to their light construction, the seed boots bent easily when the upper sweep bolt was tightened securely. This allowed the sweeps and seed boots to loosen with prolonged field use. The weld between the upper and lower portion of the seed boot also failed on a number of seed boots during the test (FIGURE 21). It is recommended that the manufacturer consider modifications to the seed boot to improve strength and prevent deflector wear due to soil forces.

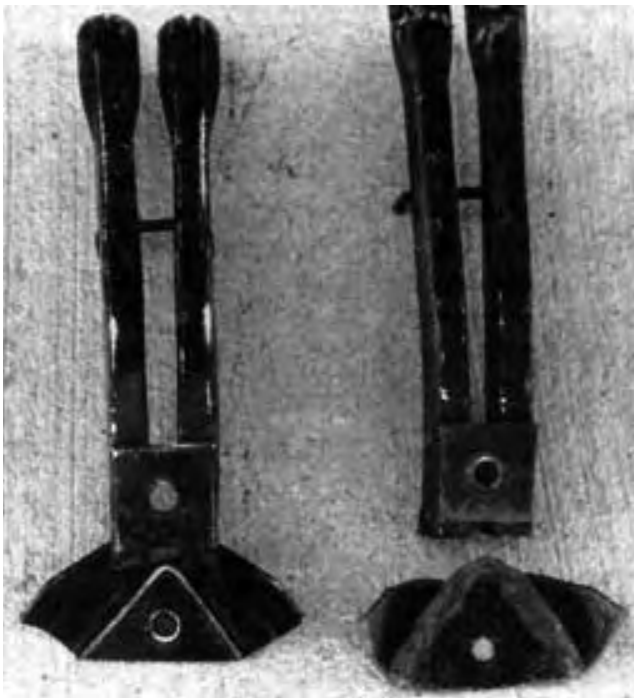

FIGURE 21. Seed Boot Failure.

**Material Loss from Pegged Rollers:** A small amount of metered material missed the metering collection cups when falling from the pegged metering rollers. This material collected on the lower metering access doors and fell on the ground when the doors were opened.

**Metering Rate Calibrations:** The metering rate calibrations shifted downward by about 10 per cent from the beginning to the end of the evaluation period. Tests indicated that a shift in the gate setting (pegged roller clearance) was the cause of the decrease in metering calibration.

## DISCUSSION OF MECHANICAL PROBLEMS APPLICATOR

**Support Brackets:** It was necessary to fabricate brackets in order to support the primary distribution tubes on the cultivator (FIGURE 20). It is recommended that some means of supporting the primary distribution tubes on the cultivator be supplied as standard equipment.

APPENDIX I	
<b>SPECIFICATIONS</b>	
<b>(A) AIR SEEDER</b>	
<b>MAKE:</b>	John Shearer Air Seeder
<b>MODEL:</b>	MK3
<b>SERIAL NUMBER:</b>	148414
<b>MANUFACTURER:</b>	John Shearer Limited Box 42 Kilkenny, South Australia 5009
<b>DIMENSIONS:</b>	
-width	130 ft (3962 mm)
-length	130 ft (3962 mm)
-height	59 ft (1798 mm)
-maximum ground clearance	11 ft (335 mm)
-wheel tread	110 ft (3353 mm)
<b>METERING SYSTEM:</b>	
-type	pegged rollers (pressurized tanks)
-number of meters	2
-drive	chain from applicator wheel
-adjustment	gear box
-air stream loading	pressurized tanks
-transfer to openers	pneumatic conveyance through divider headers and plastic tubes
-shut off	electrically operated clutch
<b>TANK CAPACITIES:</b>	
-front	50 bu (1818 L)
-rear	37 bu (1346 L)
Total	87 bu (3164 L)
<b>FAN:</b>	
-type	straight blade centrifugal
-maximum operating speed	5400 rpm
-drive	1000 rpm power take off
<b>WHEELS:</b>	
-single wheels	2, 14.9-24, 8-ply rating
<b>NUMBER OF LUBRICATION POINTS:</b>	
	23 grease fittings 2 wheel bearings
<b>HITCH:</b>	
-vertical adjustment range	
-applicator	none
-cultivator	none
<b>(B) CULTIVATOR</b>	
<b>MAKE:</b>	Edwards Cultivator
<b>MODEL:</b>	CSF 833
<b>SERIAL NUMBER:</b>	82-3-777
<b>MANUFACTURER:</b>	Edwards Rod Weeder Ltd P.O. Box 995 Lethbridge, Alberta T1J 4A2
<b>SHANKS:</b>	
-number	30
-lateral spacing	13 in (330 mm)
-trash clearance(sweep to frame)	24 in (610 mm)
-number of shank rows	3
-distance between rows	36, 30 in (914, 762 mm)
-shank cross section	2 x 1 in (50 x 25 mm)
-shank stem angle	55 degrees
-sweep hole spacing	2-1/4 in (57 mm)
-sweep bolt size	7/16 x 2 in (11 x 50 mm)

<b>HITCH:</b>		
-vertical adjustment range	12 in (305 mm), 5 positions	
<b>DEPTH CONTROL:</b>		
	hydraulic	
<b>FRAME:</b>		
-cross section	4 x 4 in (102 x 102 mm)	
-thickness	1/4 in (6.4 mm)	
<b>TIRES:</b>		
	8, 9.5L-15, 6-ply	
<b>NUMBER OF LUBRICATION POINTS:</b>		
<b>HYDRAULIC CYLINDERS:</b>		
-depth control	1, 4 x 10 in (102 x 254 mm) (not supplied)	
-wing lift	2, 5 x 16 in (127 x 406 mm)	
<b>(C) OVERALL SPECIFICATIONS FOR APPLICATOR-CULTIVATOR ASSEMBLY</b>		
<b>DIMENSIONS:</b>		
	<b>FIELD POSITION</b>	<b>TRANSPORT POSITION</b>
-width	32.5 ft (9906 mm)	19.0 ft (5791 mm)
-length	19.7 ft (6005 mm)	19.7 ft (6005 mm)
-height	6.2 ft (1890 mm)	12.8 ft (3901 mm)
-maximum ground clearance	5.0 ft (127 mm)	5.0 ft (127 mm)
-wheel tread	29.4 ft (8961 m)	10.1 ft (3078 mm)
-effective seeding width	32.5 ft (9906 m)	
<b>WEIGHTS:</b>		
	<b>TANKS EMPTY</b>	<b>TANKS FULL OF WHEAT</b>
<b>APPLICATOR</b>		
-hitch	620 lb (282 kg)	1165 lb (530 kg)
-left wheel	1955 lb (889 kg)	4425 lb (2011 kg)
-right wheel	1760 lb (800 kg)	4295 lb (1952 kg)
<b>CULTIVATOR (with attached harrows)</b>		
	<b>FIELD POSITION</b>	<b>TRANSPORT POSITION</b>
-left mainframe wheels	2200 lb (1000 kg)	3420 lb (1555 kg)
-right mainframe wheels	2190 lb (995 kg)	3340 lb (1518 kg)
-left wing wheels	1180 lb (536 kg)	
-right wing wheels	1190 lb (541 kg)	
Total, Tanks Empty	11,095 lb (5043 kg)	
Total, Tanks Full of Wheat		16,645 lb (7566 kg)

APPENDIX II	
<b>MACHINE RATINGS</b>	
The following rating scale is used in PAMI Evaluation Reports:	
Excellent	Very Good
Good	Fair
Poor	Unsatisfactory

APPENDIX III	
<b>CONVERSION TABLE</b>	
acres (ac) x 0.40	= hectares (ha)
miles/hour (mph) x 1.61	= kilometres/hour (km/h)
inches (in) x 25.4	= millimetres (mm)
feet (ft) x 0.305	= metres (m)
horsepower (hp) x 0.75	= kilowatts (kW)
pounds (lb) x 0.45	= kilograms (kg)
pounds force (lb) x 4.45	= newtons (N)
bushels (bu) x 36.4	= litres (L)
pounds/bushel (lb/bu) x 1.25	= kilograms/hectolitre (kg/hL)
pounds force/foot (lb/ft) x 0.015	= kilonewtons/metre (kN/m)
pounds/acre (lb/ac) x 1.11	= kilograms/hectare (kg/ha)



3000 College Drive South  
Lethbridge, Alberta, Canada T1K 1L6  
Telephone: (403) 329-1212  
FAX: (403) 329-5562  
<http://www.agric.gov.ab.ca/navigation/engineering/afmrc/index.html>

### Prairie Agricultural Machinery Institute

Head Office: P.O. Box 1900, Humboldt, Saskatchewan, Canada S0K 2A0  
Telephone: (306) 682-2555

Test Stations:  
P.O. Box 1060  
Portage la Prairie, Manitoba, Canada R1N 3C5  
Telephone: (204) 239-5445  
Fax: (204) 239-7124

P.O. Box 1150  
Humboldt, Saskatchewan, Canada S0K 2A0  
Telephone: (306) 682-5033  
Fax: (306) 682-5080