

Evaluation Report

295

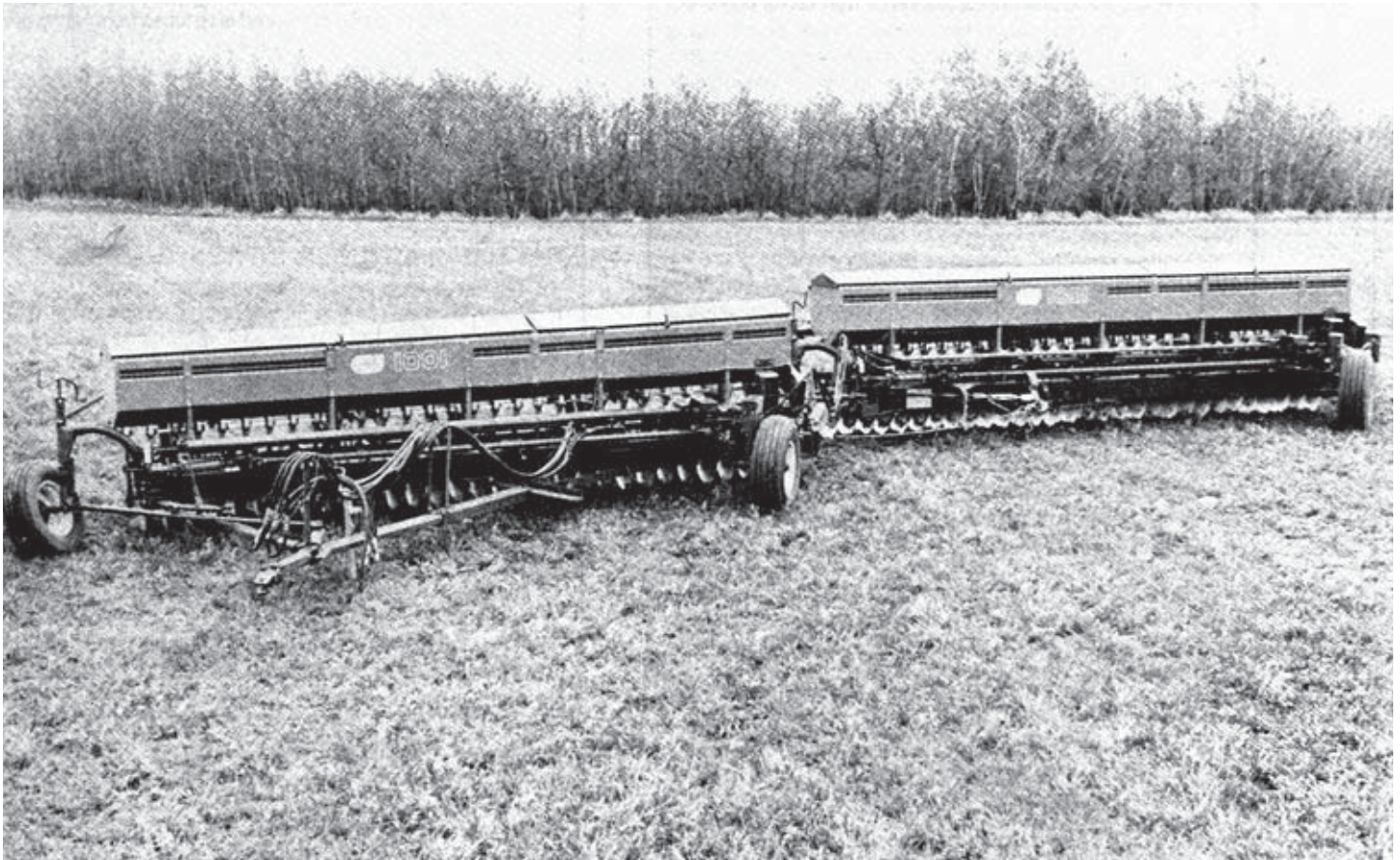

Co-op Implements 1001 Disker

A Co-operative Program Between



CO-OP IMPLEMENTS 1001 DISKER

MANUFACTURER AND DISTRIBUTOR:

Co-op Implements Limited
 770 Pandora Avenue East
 Winnipeg, Manitoba
 R2C 3N1

RETAIL PRICE:

\$22,340.00 (December, 1982, f.o.b. Humboldt. Two 4.6 m wide piggyback hitched units with three rear frame weights and packer hitch.)

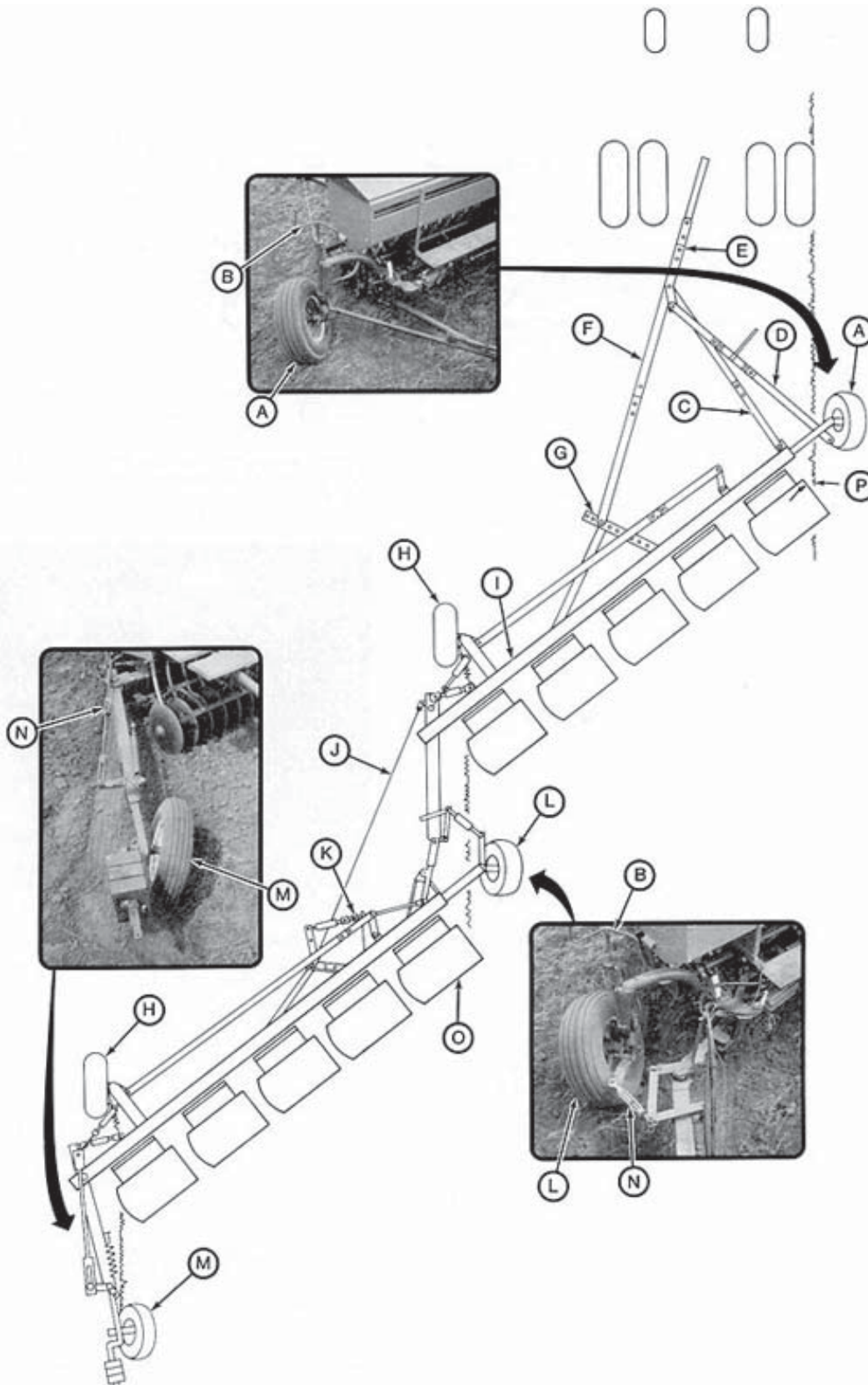

FIGURE 1. CI 1001: (A) Front Furrow Wheel, (B) Frame Levelling Screws, (C) Hitch Brace, (D) Steering Link (ratchet adjustment), (E) Front Hitch, (F) Main Hitch, (G) Main Hitch Anchor (width of cut adjustment), (H) Land Wheel, (I) Main Frame, (J) Hitch Cable, (K) Centre Furrow Wheel Lock, (L) Centre Furrow Wheel, (M) Rear Furrow Wheel, (N) Furrow Wheel Lead Adjustment, Page 2

SUMMARY AND CONCLUSIONS

Overall functional performance of the CI 1001 disk harrow was good. Penetration was very good when seeding into summerfallow or moist stubble and poor when seeding into dry compacted stubble. Ability to cut through surface trash was good in firm soils and fair in soft soils. Heavy surface trash prevented proper penetration in all fields and led to plugging in soft, moist fields.

Seed placement and seed coverage were good. In stony fields, rocks seldom lodged between the disks. The gangs rode smoothly over buried rocks and obstructions. Stability was very good in rolling hills provided the five optional rear frame weights and the centre furrow wheel lock were used. Stability was slightly affected by changes in ground speed, soil hardness and tillage depth.

The accuracy of the seed metering system was very good in wheat, oats and barley and good in rapeseed. The variation in seeding rates among seed runs was very low in wheat, oats and barley and low in rapeseed. Seeding rates were not affected by field roughness, field slope, ground speed, or depth of grain in the seed box.

Overall performance of the fertilizer attachment was very good. Variation of the application rates among runs was very low and the application rate was not affected by field roughness, field slope, ground speed or level of fertilizer in the fertilizer box.

The fertilizer rates were easy to adjust. Care was required to accurately adjust the seeding rates. The seed and fertilizer boxes were convenient to refill and clean. Moisture entered the seed cups and fertilizer boxes in driving rains. Daily lubrication took approximately 30 minutes. All lubrication points were fairly accessible.

The C11001 could be placed into full transport by two persons in 30 minutes and into semi-transport by one person in 5 minutes. Overall width in full or semi-transport was suitable for safe transport on all secondary roads. The C11001 towed well at speeds up to 30 km/h (19 mph) in semi-transport. It should not be transported at road speeds with full grain and fertilizer boxes as all tires, except the front land wheel, exceeded the Tire and Rim Association's maximum ratings by 23% to 114%. Only the centre furrow wheel was slightly overloaded when transporting with empty boxes.

Average draft for the 9.2 m (30 ft) wide test machine, in primary tillage, at 8 km/h (5 mph) varied from 20.2 kN (4450 lb) at 50 mm (2 in) depth to 32.2 kN (7100 lb) at 90 mm (3.5 in) depth.

In primary tillage, at 8 km/h (5 mph) and 75 mm (3 in) depth, a tractor with 97 kW (130 hp) maximum power take-off rating will have sufficient power reserve to operate the 9.2 m (30 ft) wide CI 1001.

The operator's manual was well written and illustrated. Several pressure grease fittings, recommended chain servicing and proper adjustment of the gang lift rods were not included in the manual. The CI 1001 was safe to operate if normal safety procedures were followed.

Several mechanical problems occurred during functional testing.

RECOMMENDATIONS

It is recommended that the manufacturer consider:

1. Installing self-locking nuts on the gang lift rods and including their proper adjustment in the operator's manual.
2. Modifications to eliminate slightly bent disks at the front of the gangs from jamming against the seed spouts.
3. Including in the operator's manual all pressure grease fittings and recommended maintenance of drive chains.
4. Strengthening the connection of the ball mount on the tail frame hitch, joining the disk harrow units.
5. Modifications to eliminate loosening of the trash guard mounting bolts.
6. Modifications to prevent the seed drop tubes from falling out of the seed spouts.

Senior Engineer - G.E. Frehlich

Project Technologist - W.F. Stock

THE MANUFACTURER STATES THAT

With regard to recommendation number:

1. The problem will be investigated. The adjusting nut has always carried a self-locking specification. Adjustment instructions will be added to the manual.
2. This recommendation will be considered.
3. The operator's manual lubrication list will be revised and maintenance information on the drive chains will be included in future issues.
4. This recommendation will be considered.
5. We will consider replacing the lock washers with self-locking nuts.
6. The seed drop tube end is sized for a close fit in the spout. The operator should wind up the tube approximately 1/2 turn to reduce its diameter for deeper insertion and a locking effect. These instructions will be added to future operator's manuals.

NOTE: This report has been prepared using SI units of measurement. A conversion table is given in APPENDIX III.

GENERAL DESCRIPTION

The CI 1001 is a 9.2 m (30 ft) wide one-way disk harrow consisting of two 4.6 m (15 ft) units hitched in a piggyback configuration. Each unit has five independent disk gangs, each containing six 508 mm (20 in) diameter disks spaced at 178 mm (7 in). Disk penetration is controlled with a hydraulic cylinder on each unit and a torsion bar on each gang. Width of cut is adjustable from 7.3 to 9.2 m (24 to 30 ft).

The CI 1001 is equipped with seeding and fertilizing attachments as standard equipment. The two grain and fertilizer boxes have a total capacity of 2330 L (64 bu) grain and 1340 kg (2950 lb) fertilizer or 1730 L (47 bu) grain and 1850 kg (4070 lb) fertilizer, depending on the position of the box partitions. Seed is metered by externally fluted feed wheels and fertilizer is metered by augers. Seed and fertilizer are delivered through common coiled steel drop tubes to metal seed spouts adjacent to each disk.

The test machine was equipped with optional rear frame weights and packer hitch. Detailed specifications are given in APPENDIX 1.

SCOPE OF TEST

The CI 1001 was operated in the conditions shown in TABLE 1 for 98 hours while tilling 450 ha (1110 ac). It was evaluated for quality of work, ease of operation and adjustment, power requirements, operator safety and suitability of the operator's manual. Of the total operating time, 65 hours were spent seeding. In addition, the seed and fertilizer systems were calibrated in the laboratory. Packers were used for some of the seeding trials.

TABLE 1. Operating Conditions

Field Condition	Hours	Field Area ha
Soil Type		
- loam	78	360
- silty clay loam	14	64
- clay	6	26
Total	98	450
Stony Phase		
- occasional stones	47	217
- moderately stony	41	185
- very stony	10	48
Total	98	450

RESULTS AND DISCUSSION

QUALITY OF WORK

Penetration: Penetration was very good when seeding into summerfallow or moist stubble and was fair when seeding into dry stubble. Penetration was poor when seeding into heavy trash or dry stubble that had been compacted. The optional three rear frame weights improved penetration, but additional weights were needed to provide penetration in hard dry soils. Penetration was improved when the grain and fertilizer boxes were full, and when calcium chloride solution or wheel weights were added to the furrow wheels. Penetration decreased slightly as ground speed increased.

The disks effectively cut through moderate amounts of surface

trash when tilling firm soils. In soft soils, trash was turned without being cut. In very heavy trash, disk penetration was non-uniform regardless of the soil conditions. Penetration in trashy fields was improved by sharpening the disks and by increasing the disk angle. Characteristic of most large disk harrows, penetration was uneven in undulating fields. The long frame and triangular wheel configuration caused irregular penetration at the bottom of ravines or gullies. To improve penetration in fields with ravines or varying soil hardness, the depth of each unit had to be controlled hydraulically from the tractor.

Penetration and seeding depth were controlled by one hydraulic cylinder for each unit and by a non-adjustable torsion bar on each disk gang (FIGURE 2). The vertical force needed to lift the disk gang out of the soil varied from 682 N (150 lb) to 2160 N (475 lb) depending on the position of the hydraulic cylinder.

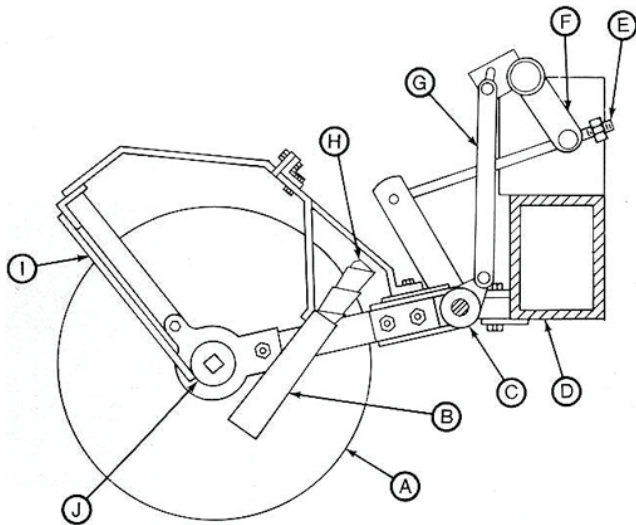

FIGURE 2. Disk Gang: (A) Disk, (B) Seed Spout, (C) Torsion Bar, (D) Main Frame, (E) Lift Rod, (F) Lift Arm, (G) Torsion Bar Linkage, (H) Coiled Seed Tube, (I) Trash Guard, (J) Gang Bearing.

Seed Placement: Seed placement was good in most field conditions. The seed tubes were positioned behind the disk (FIGURE 3) to place the seed at the bottom of the furrow. At 8 km/h (5 mph), most seeds were placed within 13 mm (0.5 in) of the average seed depth. Some seed scattering occurred at higher speeds and depths greater than 76 mm (3 in). In the bottom of ravines or gullies, seed was placed on the soil surface as the disks were unable to follow variations in ground contour.



FIGURE 3. Seed Tube Position.

Seed placement was slightly better in summerfallow than in stubble fields. In very trashy fields, seeds were placed amidst the trash if the disks failed to cut through it. If the trash was cut by the disks, the seeds were placed near the furrow bottom, and covered by a loose mixture of soil and trash.

Characteristic of all disk harrows, soil was not compacted firmly about the seeds. It is important that packers be used after seeding, especially in dry, loose or trashy soils, to aid seed germination and

plant growth.

Stability: All one-way disk harrows have a characteristically large side draft which varies with changing field conditions. As a result, some sideways movement relative to the tractor, and changes in the disk angle or width of cut occur in non-uniform or undulating fields.

Stability of the CI 1001 was very good in most field conditions if the centre furrow wheel lock and optional five rear frame weights were used. Stability was poor when the rear weights were not used. Stability can be improved by adding calcium chloride or wheel weights to the wheels, reducing ground speed or tillage depth, and increasing the disk angle and the lead on the land wheels. Extra weight is most effective when added to the rear furrow wheel.

The width of cut was only slightly affected by changing ground speeds. The width of cut varied up to 305 mm (12 in) due to variations in soil hardness. When operating on slopes up to 10°, the width of cut varied up to 457 mm (18 in). When operating down slopes greater than 10°, the rear furrow wheel left the furrow.

Ridging: The CI 1001 usually produced an even seedbed with a uniform soil surface (FIGURE 4) provided it was properly adjusted. The centre furrow wheel lock stabilized the centre furrow wheel and reduced untilled strips or overlapping between the front and rear units on steep hillsides. Slight furrow bottom ridging occurred on hillsides and gradual left turns as the width of cut increased. Furrow bottom ridging decreased with narrower widths of cut. A width of cut 10% less than the nominal width of cut is recommended for seeding to obtain a good weed kill and to provide a uniform furrow bottom for seed placement. At speeds above 11 km/h (7 mph), bouncing of the disk harrow produced an uneven seedbed.

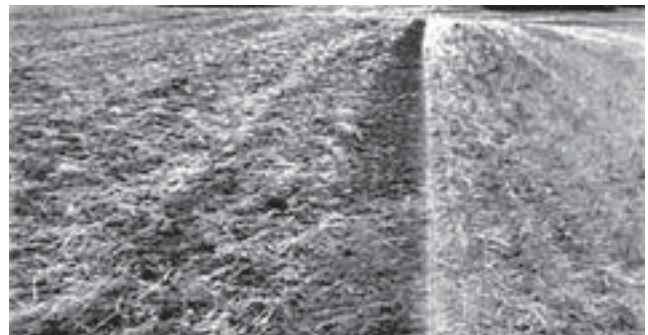

(A)



(B)

FIGURE 4. Soil Surface after Seeding into Stubble: (A) Heavy Trash Cover, (B) Light Trash Cover.

Slight soil surface ridging occurred when making gradual right turns. In dry soils, a smoother surface with fewer lumps was obtained at higher ground speeds. The front and centre furrow wheels operated too far right at the narrow widths of cut leaving a depression in the worked soil surface.

Ridging between adjacent gangs occurred when the lift rod adjustment nuts moved due to field vibrations. It is recommended that the manufacturer install self-locking nuts on the lift rods and include their proper adjustment in the operator's manual.

Plant Emergence: Plant emergence was uniform (FIGURES 5 and 6) in all fields with sufficient moisture and nutrient reserves. Emergence was delayed in hard or dry soils.

Metering Accuracy: The grain and fertilizer metering

systems (FIGURE 7) were calibrated in the laboratory using a standard procedure¹, and were compared with the manufacturer's calibrations.



FIGURE 5. Neepawa Wheat 23 Days after Seeding into Stubble. Moisture Conditions Good.



FIGURE 6. Klages Barley 24 Days after Seeding into Stubble. Moisture Conditions Good.

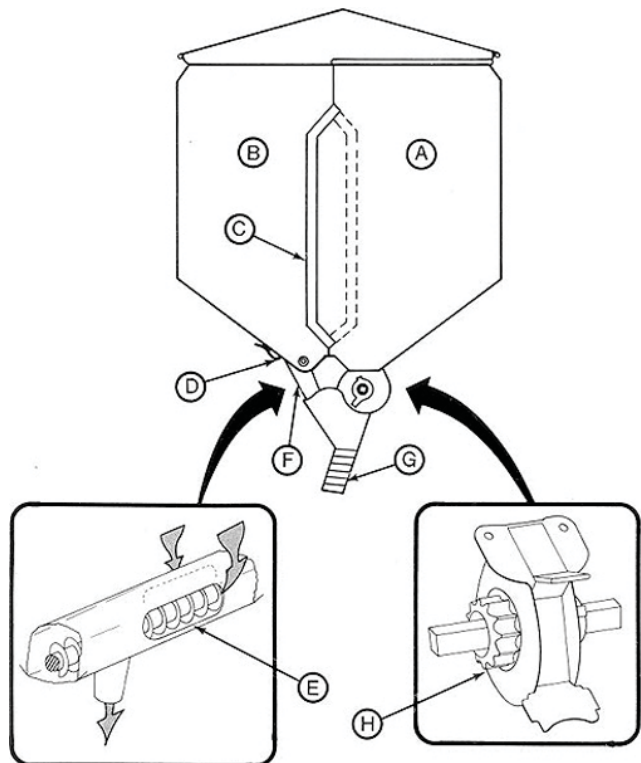

FIGURE 7. Seed and Fertilizer Metering System: (A) Grain Box, (B) Fertilizer Box, (C) Two Position Box Partition, (D) Fertilizer Cleanout Panel, (E) Fertilizer Auger, (F) Fertilizer Spout, (G) Grain and Fertilizer Drop Tube, (H) Externally Fluted Feedroll.

Since the actual application rates for certain settings depend on factors such as the size, density, moisture content of seeds and fertilizer particles, and on the width of cut, it is not practical for a manufacturer to present charts to include all possible variations. Research has shown, however, that small variations in seed or fertilizer application rates will not significantly affect grain crop yields.

Seed Metering System: Seeds such as wheat, oats and barley are metered through the seed cups using the regular speed sprocket. Flax is metered using the slow speed sprocket. For small seeds such as rapeseed, an extra slow speed sprocket is used and filler plates are installed in the seed cups.

Seed metering system accuracy was very good in wheat, barley, oats and good in rapeseed. The manufacturer's calibration charts for wheat and barley were the same as the Machinery Institute's calibrations. Some differences were obtained between the manufacturer's calibrations and the Machinery Institute's calibrations for oats and rapeseed (FIGURES 8 and 9). Differences in seeding rates will occur when using seed of different size, density and moisture content or when operating at different widths of cut. To obtain exact seeding rates, it is important to adjust for different seed properties and widths of cut.

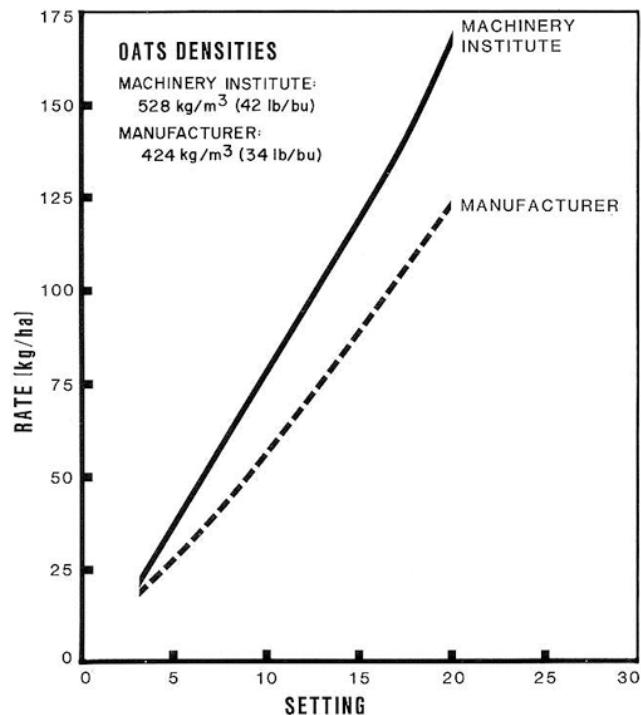

FIGURE 8. Oats Calibration.

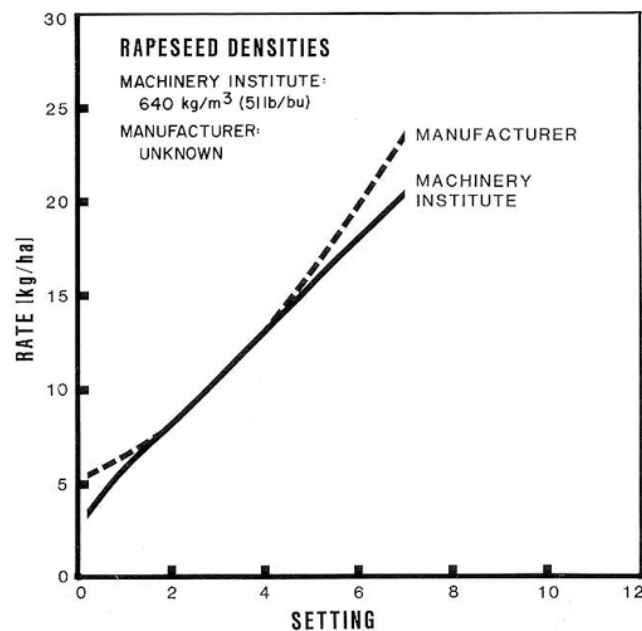

FIGURE 9. Rapeseed Calibration.

Field roughness, depth of seed in the grain box, variation in field slope or ground speed did not affect the seeding rate for either large or small seeds.

The coefficient of variation² (CV) is commonly used to describe

¹Machinery Institute T792-R79, Detailed Test Procedures for Disker Seeders.

the variation of the application rate among individual seed cups. An accepted variation for grain or fertilizer application is a CV value not greater than 15%. If the CV is less than 15%, seeding is acceptable, whereas if the CV is much greater than 15%, the variation among individual seed cups is excessive.

For wheat, oats, and barley, seeding was very uniform. For example, when seeding wheat at 85 kg/ha (75 lb/ac), the CV was only 2.5%. When seeding rapeseed at a rate of 7 kg/ha (6.2 lb/ac), the CV was 6.0%.

Fertilizer Metering System: Fertilizer metering accuracy was good. The fertilizer application rate depended on the drive sprocket used for metering seed. The actual application rates for 11-51-0 fertilizer having a density of 866 kg/m³ (69 lb/ft³) were up to 47% higher than the manufacturer's calibration when using the regular speed sprocket, and up to 60% higher when using the slow speed sprocket. The minimum fertilizer application rate obtained was 42 kg/ha (37 lb/ac) when seeding large seeds and 23 kg/ha (20 lb/ac) when seeding small seeds.

Differences in fertilizing rates will occur when using fertilizer of different size, density and moisture content or when operating at different widths of cut. To obtain exact fertilizing rates, it is important to adjust for different fertilizer properties and widths of cut. The density of fertilizer used by the manufacturer was not indicated in the operator's manual.

The variation in the fertilizing rate from one run to another was very good. For example, when distributing 11-51-0 fertilizer at a rate of 60 kg/ha (53 lb/ac), the coefficient of variation among individual feed cups was only 4.4%.

The fertilizer application rate was not significantly affected by level of fertilizer in the box, field roughness, ground speed or variation in field slope.

Grass Seeding: FIGURE 10 presents the Machinery Institute's calibration for alfalfa, obtained by using the extra slow speed drive sprocket and the seed cup filler plates. The graph is presented for operator information only, since this calibration was not given in the operator's manual.

Large light seeds such as bromegrass and ryegrass bridged over the seed cup openings and prevented the seed from being metered. Large light seeds can usually be metered by mixing the seed with heavier material such as cracked grain or fertilizer.

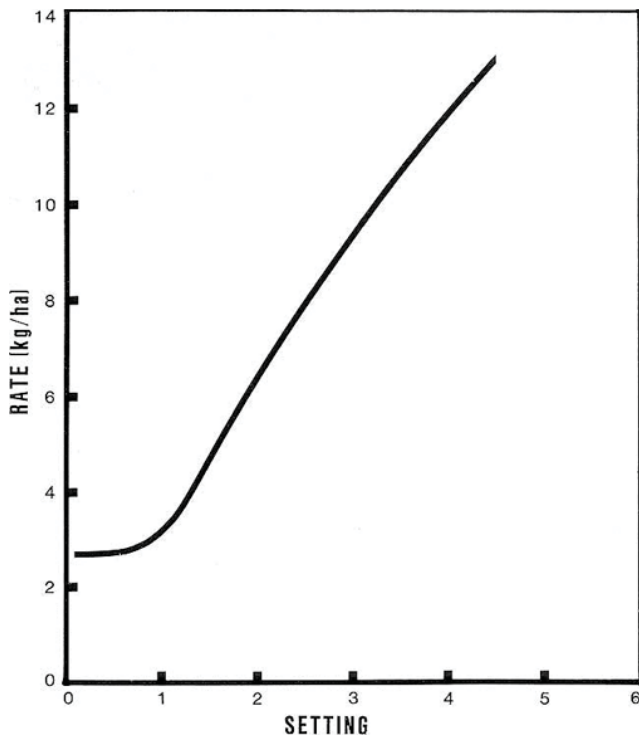

FIGURE 10. Alfalfa Calibration Using the Extra Slow Speed Drive and Seed Cup Filler Plates. Grain Density – 712 kg/m³ (57 lb/bu).

²The coefficient of variation is the standard deviation of application rates from individual seed cups expressed as a percent of the mean application data.

EASE OF OPERATION

Wet Fields: Mud buildup on the disks and loose trash occasionally caused disk plugging in wet clay fields. Plugging occurred more readily in heavy trash areas where bunched straw was pushed ahead of the gangs.

The trash guards reduced the buildup of trash, but did not prevent mud from clinging to the disks. On sharp right turns, the front seed spout plugged with mud. As is common with most one-way disk harrows, plugging occurred more readily at reduced widths of cut and greater working depths.

Stony Fields: The trash guards eliminated lodging of rocks between disks. Seed spouts frequently wedged between slightly bent disks at the front of the gang and the gang arm, to stop gang rotation. It is recommended that the manufacturer consider modifications to eliminate jamming of these disks against the seed spouts.

The torsion bar disk gangs could lift a maximum of 320 mm (12.5 in) to clear rocks and other obstructions. Disk gang force at maximum trip clearance was about 2160 N (475 lb). Under normal operating conditions, the disks rode smoothly over rocks and other obstructions.

Trashy Fields: Heavy surface trash caused poor disk penetration, poor seed placement and occasional plugging. Plugging occurred when loose clumps of straw and trash were pushed ahead of the disk gangs. On sharp right turns, plugging occurred between the front disk and the trash guard. Plugging due to trash was more frequent in wet fields than in firm, dry fields.

Changing Disks: Disk gangs were easily removed by removing two bolts on the disk gang frame and four bolts on the trash guards. One nut with a metal locking tab tightened the disks on the disk gang arbor bolt. Once removed, the disks were easily replaced. New disks should be installed at the rear of the disk gang to maintain uniform penetration.

Filling: Two lids for each unit covered both the grain and fertilizer compartments. Interior grain covers prevented the grain and fertilizer from being mixed when filling. The lids could be reversed to permit filling from the front or rear.

A walkway was provided at the front of the machine for easy access. The partition between the grain and fertilizer boxes (FIGURE 7) could be set in two positions to suit application rates, thereby minimizing downtime for filling. This permitted carrying 2330 L (64 bu) of grain and 1340 kg (2950 lb) of fertilizer or 1730 L (47 bu) of grain and 1850 kg (4070 lb) of fertilizer. Grain and fertilizer level indicators were not provided.

Moisture: The grain box was adequately sealed, but moisture entered through the side plates of the seed cups in driving rains. In light rains, moisture entered the fertilizer box at the corners of the drop out panels. If the disk harrow is allowed to stand out in the rain, the fertilizer shafts should be checked before operation to ensure that they rotate freely and that the fertilizer has not caked.

Cleaning: The grain box lid opened wide permitting easy access for cleaning with a brush or vacuum cleaner, but not a 20 L (5 gal) pail.

The tapered fertilizer boxes were easily cleaned by removing bottom dropout panels, which were equipped with quick release latches. However, several panels were difficult to remove due to interference by the packer hitch. About 20 kg (44 lb) of fertilizer could not be metered from the fertilizer box. Visibility and access into the bottom of the fertilizer box were very good.

Acremetre: The CI 1001 was equipped with an acremetre that recorded the nearest tenth acre up to 1000 acres. The accuracy of the acremetre depended upon the width of cut. At the suggested seeding width of 90% of nominal width, the acremetre was accurate to within 1%. A metric counter was not available.

Turning: Left 90° turns were easily made. Sharp left turns greater than 90° caused skidding of the rear land wheel (FIGURE 11). Tilled corners were smooth and could easily be covered by two passes when finishing the field. Sharp right turns had to be made with caution due to interference between the tractor tire and the front unit. When making right turns, the gangs should be raised to reduce draft and prevent possible disk damage in stony fields.

Transporting: The CI 1001 could be safely transported at speeds up to 34 km/h (21 mph) when in full transport position, providing the seed and fertilizer boxes were empty. It could be put into or taken out of full transport by two men in about 30 minutes. A

jack and adjustable front hitch made hitching to the tractor easy. A lock on the hydraulic cylinder prevented the disk gangs from being lowered while transporting. Damage could not occur when the hydraulics were activated with the lock engaged. Transport width was narrow enough to allow most vehicles to pass on secondary roads (FIGURE 12).



FIGURE 11. Skidding of the Rear Land Wheel when Making Sharp Left Turns.



FIGURE 12. Full Transport Position.

The CI 1001 could be safely transported at speeds up to 30 km/h (19 mph) in semi-transport. Semi-transport width with the hitch brace collapsed was narrow, making transport on secondary roads safe and easy (FIGURE 13). The CI 1001 could be placed in or taken out of semi-transport by one person in about 5 minutes. Wheel lead adjustments for semi-transport did not affect field settings. Right or left turns were easily made in semi-transport.



FIGURE 13. Semi-Transport Position with Hitch Brace Collapsed.

EASE OF ADJUSTMENT

Width of Cut: The width of cut was adjustable from 7.3 to 9.2 m (24 to 30 ft) depending upon soil conditions, operating depth and ground speed. The width of cut was set by adjusting the position of the main hitch on the main hitch anchor. Large hitch adjustments were difficult requiring fore-and-aft movement of the main hitch. Large adjustments also required setting the wheel leads and lengthening or shortening the hitch cable to make the two units parallel. Adjustments were adequate to maintain the width at 90% of

nominal width in varying soil conditions.

Tillage Depth: The depth of tillage was determined by the position of the hydraulic cylinder on each unit and by the position of the lift rod nut on each disk gang. The hydraulic cylinders were easily adjusted from the tractor. An adjustable stop on the cylinder aided in setting the desired depth.

Individual unit frames were easily levelled with levelling screws at the front of each unit. The lock on the levelling screws occasionally worked loose if not sufficiently tightened.

The cylinder position indicator on the front unit was useful for initial cylinder setting but the indicator on the rear unit could not be seen from the tractor.

Lubrication: Seventy-two pressure grease fittings required greasing daily. The wheel bearings are to be cleaned and repacked with grease each season. The fertilizer system and seed cups had to be coated with oil and diesel fuel at the end of the season.

Daily lubrication took about 30 minutes. All lubrication points were accessible. A number of pressure grease fittings were not mentioned in the operator's manual.

Seeding and Fertilizing Rates: Care was required to accurately set the seeding rate because of play and binding in the linkage. The spring loaded feedrolls occasionally jammed when setting the seeding rate, and had to be tapped into position with a hammer. Filler plates were easily installed with one screw in each feed cup for seeding small seeds. The seed drive speeds were easily changed. The rate selection level and the seed cups required zeroing at the start of the season.

The fertilizing rates were easily adjusted by moving the chain onto one of seven sprocket combinations in the drive box, or by switching the sprockets on the drive box output and the fertilizer metering shaft.

POWER REQUIREMENTS

Draft Characteristics: FIGURE 14 shows draft requirements for one-way disk harrows in typical primary tillage at a speed of 8 km/h (5 mph). This figure gives average requirements based on tests of twelve machines in 38 different field conditions.

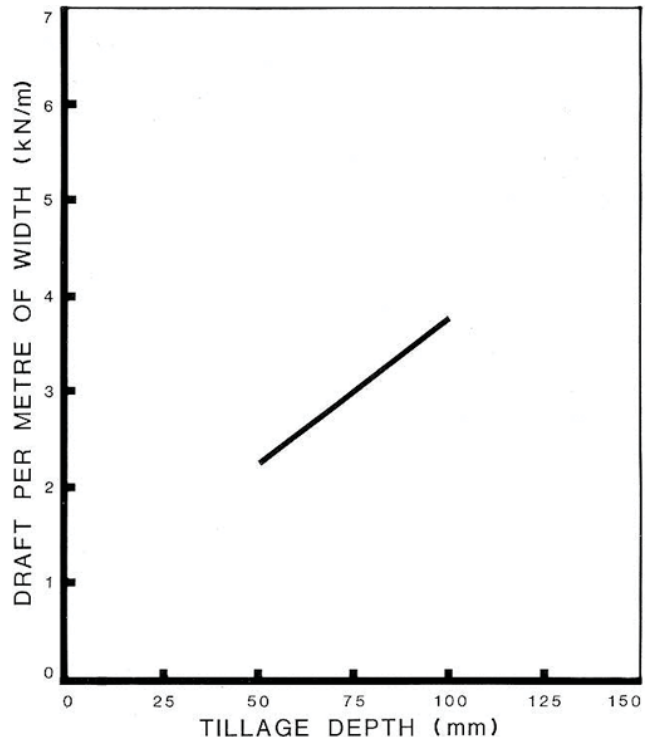

FIGURE 14. Average Draft Requirements for One-Way Disk Harrows at 8 km/h.

It is impossible to make meaningful comparisons of the draft requirements of different makes of one-way disk harrows. Draft requirements for the same one-way disk harrow, in the same field, may vary by as much as 30% in two different years due to changes in soil conditions. Variation in soil conditions affect draft much more than variation in machine make, usually making it impossible to

measure any significant draft differences between different makes of one-way disk harrows. The difficulty in accurately measuring and controlling the depth of tillage, which directly affects draft requirements, further complicates direct draft comparisons.

In primary tillage, average draft at 8 km/h (5 mph), varied from 2.2 kN/m (147 lb/ft) of width at 50 mm (2 in) depth to 3.5 kN/m (235 lb/ft) of width at 90 mm (3.5 in) depth. This represents a total draft from 20.2 to 32.2 kN (4500 to 7000 lb) for the 9.2 m (30 ft) test machine.

Increasing speed by 1 km/h, increased draft by about 134 N/m of width (a draft increase of 14 lb/ft of width for a 1 mph speed increase). For the 9.2 m (30 ft) wide test machine, this represents a draft increase of 1.23 kN for a 1 km/h speed increase (430 lb for a 1 mph speed increase).

Tractor Size: TABLE 2 shows tractor power ratings needed to operate the 9.2 m (30 ft) wide CI 1001 in primary tillage. Tractor power requirements have been adjusted to include tractive efficiency and are based on the tractor operating at 80% of maximum power on a level field. The tractor Sizes presented in the table are the maximum power take-off rating, as determined by Nebraska tests or as presented by the tractor manufacturer. Tractors selected according to this table will have ample power reserve to operate the CI 1001 in primary tillage.

Tractor size may be determined from TABLE 2 by selecting the desired tillage depth and speed. For example, at a depth of 75 mm (3 in) and a speed of 8 km/h (5 mph), a 97 kW (130 hp) tractor is needed to operate the CI 1001.

TABLE 2. Tractor Size (Maximum Power Take-Off Rating, kW) to Operate the 9.2 m Wide CI 1001 in Primary Tillage

Depth mm	Speed km/h					
	5	6	7	8	9	10
50	37	48	59	72	82	101
75	53	66	81	97	114	132
89	61	77	93	111	130	149
100	68	85	103	122	142	164

OPERATOR SAFETY

The CI 1001 was safe to operate if normal safety precautions were observed.

The front furrow wheel, centre furrow wheel and rear land wheel exceeded the Tire and Rim Association maximum ratings by 50%, 82% and 18% respectively when operating in the field with full grain and fertilizer boxes. No overload occurred with empty boxes. The front furrow wheel, centre furrow wheel, rear land wheel and rear furrow wheel were overloaded by 77%, 114%, 23% and 39% respectively when transporting with full boxes at speeds above 16 km/h (10 mph). There was a 20% overload on the centre furrow wheel when transporting with empty boxes.

Each unit was equipped with a slow moving vehicle decal that was readily visible when transporting.

OPERATOR'S MANUAL

The operator's manual was very well written and illustrated and presented useful information on operation and adjustment of the machine. Both English and Metric calibration charts were included. The operator's manual did not include gang lift rod settings, several pressure grease fittings, or recommended maintenance of the drive chains. It is recommended that these be included in the operator's manual.

DURABILITY RESULTS

The CI 1001 was operated for 98 hours while tilling about 450 ha (1110 ac). The intent of the test was to evaluate the functional performance of the machine and an extended durability evaluation was not conducted. TABLE 3 outlines the mechanical problems that occurred during the functional testing.

DISCUSSION OF MECHANICAL PROBLEMS

Multiple Hitch Mount: The pipe mount for the ball joining the front and rear harrow units broke away from the tail frame hitch and was rewelded. It is recommended that the manufacturer strengthen the ball mount connection on the tail frame hitch.

Loose Bolts: The bolts on the mounting bracket for the trash guards and seed spouts required tightening every few days. It is recommended that the manufacturer consider modifications to

eliminate loosening of the trash guard mounting bolts.

Seed Drop Tubes: Occasionally a seed drop tube fell out of the seed spout. It is recommended that the manufacturer consider modifications to prevent the seed drop tubes from falling out of the seed spouts.

Disks: Only the front disks on the gangs were damaged during the test. The remaining disks were suitable for resharpening. Most of the bent disks could be straightened on a hydraulic press. Extreme caution is recommended when straightening disks to prevent serious injury. Disk damage was high due to operating in very stony conditions. No damage occurred to the disk gang frames.

TABLE 3. Mechanical History

Item	Hours	Field Area ha
-One seed metering wheel was damaged and replaced at	34	145
-One disk spool broke while operating in rocks and was replaced at	69	313
-One trash guard mounting bracket broke and was welded at	69	313
-The mount for the ball joining the two disk harrow units failed and was rewelded at	69, 95	313, 424
-The gang lift rod nuts and the trash guard mounting bolts required frequent tightening		during the test
-The seed drop tubes occasionally fell out of the seed spouts		during the test
-The lid hinge rods bent or the lid came out of its hinges during dosing if the fertilizer box was heaped with fertilizer		during the test
-Three seed drop tubes were damaged by broken disks and repaired		during the test
-Ten disks were bent and six were broken		during the test

**APPENDIX I
SPECIFICATIONS**

MAKE:	Co-op Discer		
MODEL:	1001		
SERIAL NUMBER:			
-- front unit	31499		
-- rear unit	31501		
HITCH CONFIGURATION:			
-- number of units	2		
-- hitch type	piggyback		
OVERALL DIMENSIONS:	Field	Semi-Transport	Transport
-- height	1460 mm	1460 mm	1460 mm
-- width	10,200 mm	3708 mm	3250 mm
-- with packer hitch	10,600 mm	4420 mm	3988 mm
-- ground clearance	228 mm	28 mm	228 mm
-- nominal seeding width	9144 mm		
SEED METERING SYSTEM:			
-- type	externally fluted feed rolls		
-- drive	chain driven from land wheel		
-- adjustment	lever controlling feed roll protrusion into seed cup		
-- transfer to openers	coiled steel tubing to metal seed spouts mounted on disk gangs		
FERTILIZER METERING SYSTEM:			
-- type	auger		
-- drive	chain driven from land wheel		
-- adjustment	change auger speed by repositioning chain on a series of sprockets		
-- transfer to openers	plastic tube to top of seed tubes		
DISK GANGS:			
-- number of disks per unit	30		
-- number of gangs per unit	5		
-- number of disks per gang	6		
-- disk diameter	508 mm		
-- disk thickness	4.4 mm (7 gauge)		
-- disk concavity	59 mm		
-- disk spacing	178 mm		
TIRES:			
-- number	5		
-- size	3, 11L x 15, 6-ply 1, 11L x 15, 8-ply 1, 6.70 x 15, 4-ply		

GRAIN AND FERTILIZER BOX CAPACITIES:

-- grain box capacity	2330 L 1730 L
-- fertilizer box capacity	1340 kg 1850 kg

WEIGHT:	Boxes Empty	Boxes Full
-- weight on front furrow wheel	970 kg	1685 kg
-- weight on front land wheel	544 kg	930 kg
-- weight on centre furrow wheel	1360 kg	2414
-- weight on rear land wheel	653 kg	1175 kg
-- weight on rear furrow wheel	600 kg	862 kg
Total Weight	4127 kg	7066 kg

LUBRICATION POINTS:

-- 10h	72 pressure grease fittings
-- seasonal	wheel bearings

NUMBER OF CHAIN DRIVES:

12

NUMBER OF HYDRAULIC LIFTS:

2

NUMBER OF HYDRAULIC LIFTS:

26

OPTIONAL EQUIPMENT:

packer hitch, coil packers, rear frame weights, seed cup filler plates, 457 mm diameter disk blades

**APPENDIX II
MACHINE RATINGS**

The following rating scale is used in Machinery Institute Evaluation Reports:

- | | |
|--------------|-------------------|
| a) excellent | d) fair |
| b) very good | e) poor |
| c) good | f) unsatisfactory |

**APPENDIX III
CONVERSION TABLE**

1 kilometre/hour (km/h)	= 0.6 miles/hour (mph)
1 metre (m)	= 3.3 feet (ft)
1 millimetre (mm)	= 0.04 inches (in)
1 kilogram (kg)	= 2.2 pounds mass (lb)
1 kilowatt (kW)	= 1.3 horsepower (hp)
1 hectare (ha)	= 2.5 acres (ac)
1 litre (L)	= 0.03 bushels (bu)
1 newton (N)	= 0.2 pounds force (lb)
1 kilonewton (kN)	= 220 pounds force (lb)
1 kilogram/hectare (kg/ha)	= 0.9 pounds/acre (lb/ac)



3000 College Drive South
Lethbridge, Alberta, Canada T1K 1L6
Telephone: (403) 329-1212
FAX: (403) 329-5562
<http://www.agric.gov.ab.ca/navigation/engineering/afmrc/index.html>

Prairie Agricultural Machinery Institute

Head Office: P.O. Box 1900, Humboldt, Saskatchewan, Canada S0K 2A0
Telephone: (306) 682-2555

Test Stations:

P.O. Box 1060
Portage la Prairie, Manitoba, Canada R1N 3C5
Telephone: (204) 239-5445
Fax: (204) 239-7124

P.O. Box 1150
Humboldt, Saskatchewan, Canada S0K 2A0
Telephone: (306) 682-5033
Fax: (306) 682-5080