

Evaluation Report

284

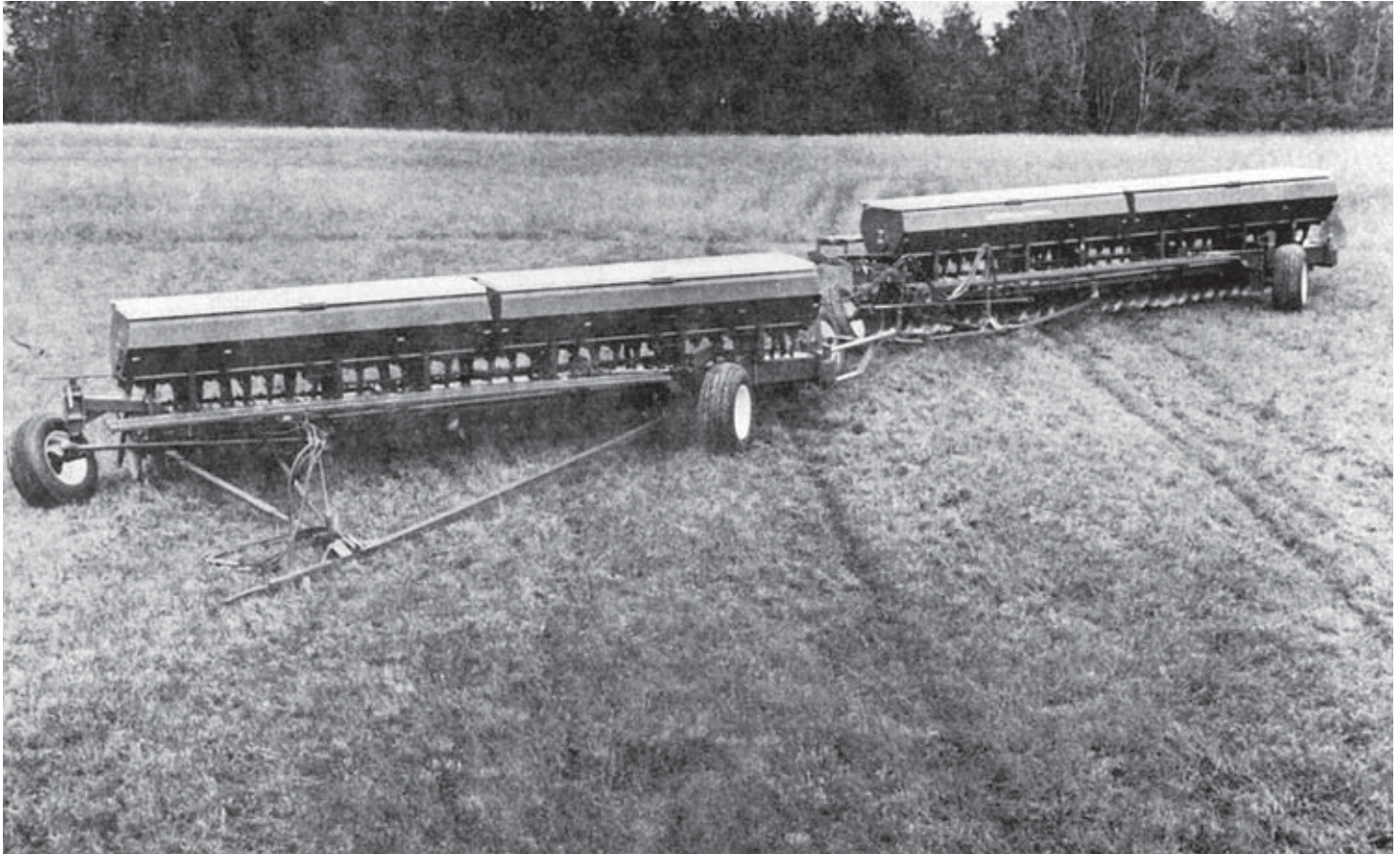

International Harvester 310 Diskall

A Co-operative Program Between



INTERNATIONAL HARVESTER 310 DISKALL

MANUFACTURER:

International Harvester Company of Canada Limited
 208 Hillyard Street
 Hamilton, Ontario
 Canada

DISTRIBUTOR:

International Harvester Company of Canada Limited
 660 Wall Street
 Winnipeg, Manitoba
 R3C 2W8

RETAIL PRICE:

\$22,930.00 (December, 1981, f.o.b. Humboldt. Two 4.9 m wide tandem hitched units with cast iron rear furrow wheel, furrow wheel weights on the front unit, rear furrow wheel return springs, disk scraper attachment, trash bar attachment and packer hitch attachment.)

3501-8th Street
 Saskatoon, Saskatchewan
 S7H 0W5

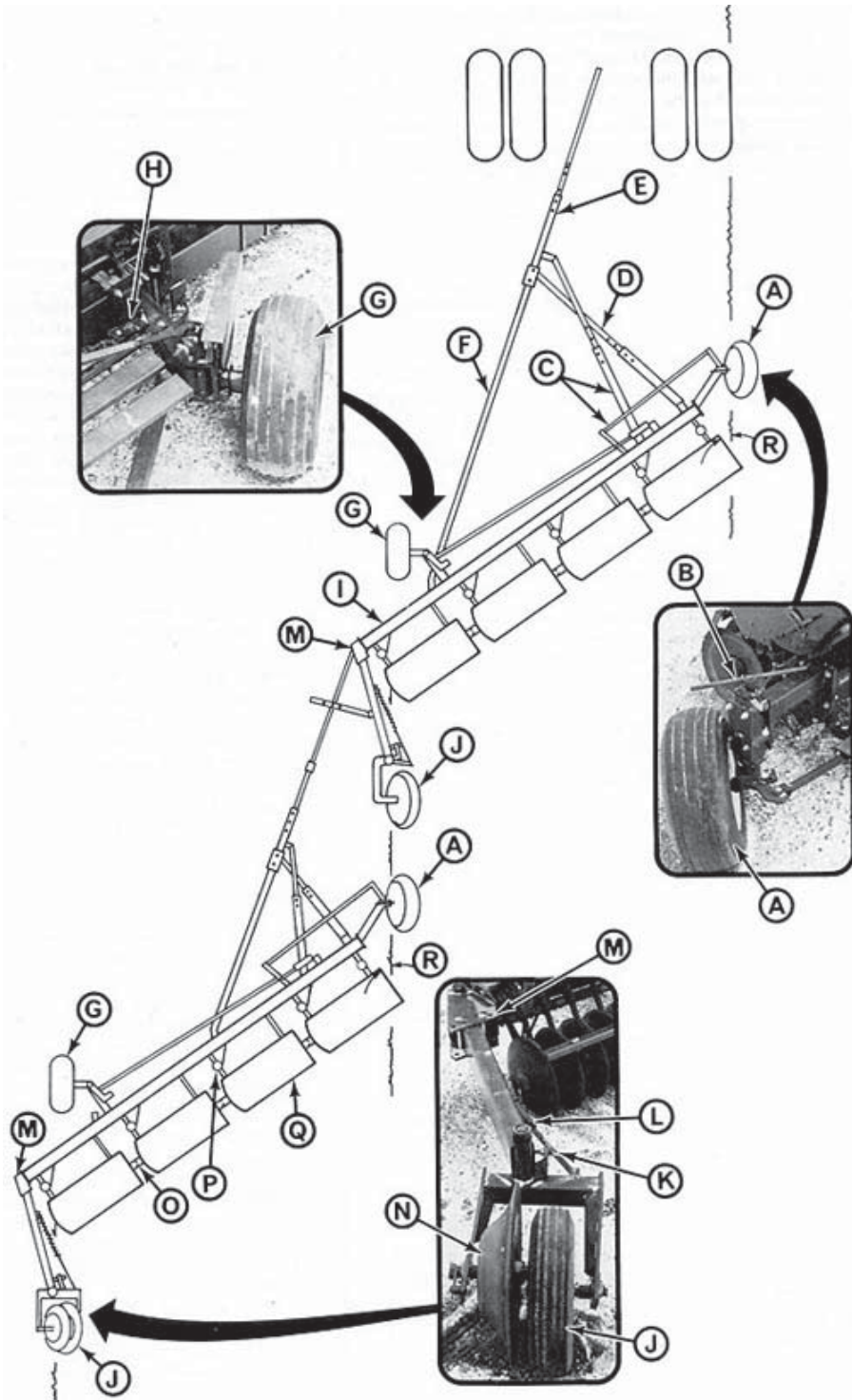

FIGURE 1. International Harvester 310 (A) Front Furrow Wheels, (B) Frame Levelling Screws, (C) Steering Links, (D) Hitch Brace, (E) Front Hitch, (F) Main Hitch, (G) Land Wheels, (H) Land Wheel Lead Adjustment, (I) Main Frame, (J) Rear Furrow Wheels, (K) Rear Furrow Wheel Lead Adjustment, (L) Rear Furrow Wheel Control Spring, (M) Width of Cut Adjustment, (N) Cast Iron Furrow Wheel (rear unit only), (O) Flexible Gang Connector, (P) Depth Control Springs, (Q) Disk Gangs, (R) Disk Angle.

SUMMARY AND CONCLUSIONS

Overall functional performance of the International Harvester 310 disk harrow was good. Penetration was very good when seeding into summerfallow or moist stubble and good when seeding into dry compacted stubble. Ability to cut through surface trash was good in firm soils and fair in soft soils. Heavy surface trash prevented proper penetration in most fields and led to plugging in soft, moist fields.

Seed placement and seed coverage were good. In stony fields, rocks occasionally lodged between the disks. The gangs rode freely over buried rocks and obstructions with minimal damage. The optional disk scrapers reduced the amount of soil clinging to the disks, but did not prevent plugging in wet clay soils. Stability was very good in rolling hills provided the rear cast iron furrow wheel was used. Stability was slightly affected by changes in ground speed, soil hardness and tillage depth.

The accuracy of the seed metering system was very good in wheat, oats and barley and good in rapeseed. The variation in seeding rates among seed runs was very low in wheat, oats, barley, and was acceptable in rapeseed. Seeding rates were not affected by field roughness, field slope, ground speed or depth of grain in the seed box.

Overall performance of the fertilizer attachment was very good. Variation of the application rates among runs was very low and the application rate was not affected by field roughness, field slope, ground speed or level of fertilizer in the fertilizer box.

Both the seed and fertilizer rates were easy to adjust. The seed and fertilizer boxes were convenient to refill and clean, but moisture entered the boxes in heavy rains. Daily lubrication took at least 30 minutes. All except four lubrication points were readily accessible.

The International Harvester 310 could be placed into full transport position in 10 minutes and into semi-transport position in 3 minutes. Overall width in full or semi-transport was suitable for safe transport on all secondary roads. The IH 310 towed well at speeds up to 25 km/h (16 mph). The IH 310 should not be transported at road speeds with full grain and fertilizer boxes as all tires exceeded the Tire and Rim Association's maximum ratings by 32% to 67%. Only the rear furrow wheel was slightly overloaded when transporting with empty boxes.

Average draft for the 9.8 m (32 ft) wide test machine in primary tillage, at 8 km/h (5 mph) varied from 21.5 kN (4747 lb) at 50 mm (2 in) depth to 34.3 kN (7573 lb) at 90 mm (3.5 in) depth.

In primary tillage, at 8 km/h (5 mph) and 75 mm (3 in) depth, a tractor with 103 kW (139 hp) maximum power takeoff rating will have sufficient power reserve to operate the 9.8 m (32 ft) wide International Harvester 310.

The operator's manual was adequately written and illustrated, but did not include a description of several important machine adjustments. The International Harvester 310 was safe to operate if normal safety procedures were followed.

Several mechanical problems occurred during functional testing.

RECOMMENDATIONS

It is recommended that the manufacturer consider:

1. Modifying the grain box lids to prevent binding when closing.
2. Supplying a jack for the main hitch.
3. Supplying a transport lock to prevent the disk gangs from lowering during transport.
4. Increasing the lead adjustment range of the rear furrow wheel.
5. Modifying the rear disk gang spring adjustment to increase the range and convenience of adjustment.
6. Modifying the seed drop tube holders to prevent the seed tubes from bending and remaining out of position after raising and lowering the gangs.
7. Including in the operator's manual information on adjustments for setting the two units parallel, the rear disk gang force and the cut of the front disk of the rear unit.
8. Modifying the hitch brace to eliminate buckling when making sharp right turns.

Senior Engineer: G.E. Frehlich

Project Technologist: W.F. Stock

THE MANUFACTURER STATES THAT

With regard to recommendation number:

1. The binding condition of the grain box lids is under investigation.
2. A hitch jack is supplied on the front unit on a triplex machine. A hitch jack for the duplex machine will be considered.
3. An additional note in the operator's manual will recommend using a depth control cylinder and will include instructions to move the cylinder depth collar against the stop valve poppet when transporting.
4. It is suspected that the bolt supplied was too short for the specific application. This matter is under investigation.
5. The limited range and the difficulty of adjusting the rear disk gang spring will be investigated. The front spring on the front gang, which requires adjustment for various soil conditions is convenient to adjust.
6. The seed tubes should be free to slide in the loop of the seed tube holder and slight bending of the tubes is not detrimental. However this will be checked by our quality control department.
7. The operator's manual (No. 1097 076 R3, 12-81) indicates the multiple units must be operated at the same angle, and hitching data on pages 12, 13, 14 and 15 indicate proper settings. Additional information will be provided to indicate the importance of the adjustment of the furrow wheels and the method for setting the rear disk gang force, and the cut of the front disk of the rear unit.
8. Increasing the strength of the hitch brace is under investigation.

NOTE: This report has been prepared using SI units of measurement. A conversion table is given in APPENDIX III.

GENERAL DESCRIPTION

The International Harvester 310 is a 9.8 m (32 ft) wide one-way disk harrow consisting of two 4.9 m (16 ft) units hitched in tandem. Each unit has four disk gangs joined together with ball and socket connections that allow the disk gangs to flex. Each gang contains eight 508 mm (20 in) diameter disks spaced at 178 mm (7 in). Disk penetration is controlled with a hydraulic cylinder and five tension springs on each unit. Width of cut is adjustable from 7.9 to 9.7 m (26 to 32 ft).

The International Harvester 310 is equipped with seeding and fertilizing attachments as standard equipment. The two grain and fertilizer boxes have a total capacity of 2400 L (66 bu) grain and 1365 kg (3005 bu) fertilizer or 1905 L (52 bu) grain and 1865 kg (4108 lb) fertilizer, depending on the position of the box partitions. Seed is metered by externally fluted feed wheels and fertilizer is metered by star-shaped traction wheels. Seed and fertilizer are delivered through common drop tubes adjacent to each disk.

The test machine was equipped with optional disk scrapers, trash bars, rear furrow wheel return springs, rear furrow wheel weights on the front unit and a cast iron rear furrow wheel on the rear unit.

Detailed specifications are given in APPENDIX I.

SCOPE OF TEST

The International Harvester 310 was operated in the conditions shown in TABLE 1 for 85 hours while tilling about 434 ha (1070 acres). It was evaluated for quality of work, ease of operation, ease of adjustment, power requirements, operator safety and suitability of the operator's manual. Of the total operating time, 32 hours were spent seeding. In addition, the seed and fertilizer systems were calibrated in the laboratory.

Packers were not used during the seeding trials.

RESULTS AND DISCUSSION QUALITY OF WORK

Penetration: Penetration was very good when seeding into summerfallow or into moist stubble and was good when seeding into dry stubble. Penetration was fair when seeding into heavy trash or dry stubble that had been compacted. The optional cast iron rear

furrow wheel was needed to provide adequate penetration in all conditions. Penetration was improved when the grain and fertilizer boxes were full and when calcium chloride or wheel weights were added to the furrow wheels. Penetration decreased slightly as ground speed increased.

TABLE 1. Operating Conditions

| Field Condition | Hours | Field Area ha |
|---------------------|-------|---------------|
| Soil Type | | |
| - silty loam | 45 | 261 |
| - light loam | 10 | 44 |
| - loam | 30 | 129 |
| Total | 85 | 434 |
| Stony Phase | | |
| - stone free | 12 | 68 |
| - occasional stones | 38 | 210 |
| - moderately stony | 30 | 136 |
| - very stony | 5 | 20 |
| Total | 85 | 434 |

The disks effectively cut through moderate amounts of surface trash when tilling firm soils. In soft soils, trash was turned without being cut. In very heavy trash, disk penetration was non-uniform regardless of the soil conditions. Penetration in trashy fields was improved by sharpening the disks and by increasing the disk angle. Characteristic of most large disk harrows, penetration was uneven in rough, undulating fields. The long frame and triangular wheel configuration caused irregular penetration at the bottom of steep ravines or gullies. The flexing disk gang connections aided in following changing ground contours. To improve penetration in rough, undulating fields, the depth setting of each unit had to be controlled hydraulically from the tractor.

Penetration and seeding depth were controlled by one hydraulic cylinder and five tension springs on each unit (FIGURE 2). The tension springs could be adjusted individually to obtain even penetration of the disk gangs in hard soils. The vertical force needed to lift a disk gang out of the soil varied from 1150 N (250 lb) to 5255 N (1160 lb), depending upon the disk gang and the position of the hydraulic cylinder.

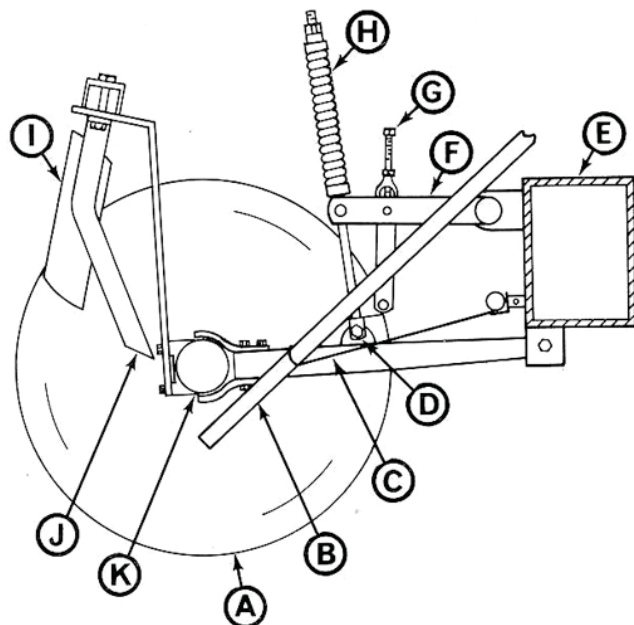

FIGURE 2. Disk Gang: (A) Disk, (B) Seed and Fertilizer Drop Tube, (C) Seed Tube Holder, (D) Spring Force Adjustment Bolt, (E) Main Frame, (F) Lift Arm, (G) Front Disk Gang Levelling Screw, (H) Tension Spring, (I) Scraper, (J) Rock Deflector and Trash Bar, (K) Gang Bearing.

Seed Placement: Seed placement was good in most field conditions. The seed tubes were positioned behind the disk as shown in FIGURE 3 to place the seed at the bottom of the furrow. At 8 km/h (5 mph), most seeds were placed within 12 mm (0.5 in) of the average seed depth. Higher speeds caused some seed scattering. Seed placement was slightly better in summerfallow than in stubble fields. In very trashy fields, seeds were placed amidst the trash if the disks failed to cut through it. If the trash was cut by the disks, the

seeds were placed near the furrow bottom, and covered by a loose mixture of soil and trash. Seed placement in rough undulating fields was variable. In the bottom of steep ravines or gullies, seed was placed on the soil surface as the disks were unable to follow sharp variations in ground contour. As is characteristic of disk harrows, soil was not compacted firmly about the seeds. It is important that packers be used after seeding, especially in dry, loose or trashy soils, to aid seed germination and plant growth.



FIGURE 3. Seed Tube Position.

Stability: All one-way disk harrows have a characteristically large side draft, which varies with changing field conditions. As a result, some sideways movement relative to the tractor, and changes in the disk angle or width of cut occur in non-uniform or undulating fields.

Stability of the International Harvester 310 was very good in most field conditions, provided the optional cast iron rear furrow wheel and furrow wheel return springs were used. Stability was poor when the cast iron furrow wheel was not used. Stability can be improved by adding calcium chloride or wheel weights to the wheels, by operating at reduced speeds, by reducing the tillage depth, and by increasing the disk angle. Extra weight is most effective when it is added to the rear furrow wheels.

The width of cut was only slightly affected by changing ground speeds. The width of cut varied up to 305 mm (12 in) due to variations in soil hardness. When operating on side slopes up to 10° width of cut varied up to 355 mm (14 in). The cast iron rear furrow wheel did not leave the furrow when operating down slopes greater than 10°. The disk harrow was slightly more stable when tilling uphill or on a hillside sloping down to the right than when tilling downhill or on a hillside sloping down to the left.

Ridging: The International Harvester 310 usually produced an even seedbed with a uniform soil surface (FIGURE 4) provided it was properly adjusted and the tractor driven at a steady speed and consistent distance from the furrow. The tandem hitch left untilled strips between the front and rear units on gradual left turns. Slight furrow bottom ridging occurred on hillsides and gradual left turns as the width of cut increased. Furrow bottom ridging decreased with narrower widths of cut. A width of cut 10% less than the nominal width of cut is recommended for seeding to obtain a good weed kill and to provide a uniform furrow bottom for seed placement. At speeds above 9.6 km/h (6 mph), bouncing of the disk harrow produced an uneven seedbed. No soil surface ridging occurred when making gradual right turns. In dry soils, a smoother surface with fewer lumps was obtained at higher ground speeds.

Seed Emergence: Seed emergence was uniform (FIGURE 5) in all fields with sufficient moisture and nutrient reserves.

Emergence was delayed in hard soil or heavy trash areas of dry stubble fields (FIGURE 6).

Metering Accuracy: The grain and fertilizer metering systems (FIGURE 7) were calibrated in the laboratory, using a standard procedure¹ and were compared with the manufacturer's calibrations.

Since the actual application rates for certain settings depend on factors such as the size, density, moisture content of seeds and fertilizer particles, and on the width of cut, it is not practical for a

¹Machinery Institute T792-R79, Detailed Test Procedures for Disker Seeders.

manufacturer to present charts to include all possible variations. Research has shown, however, that small variations in seed or fertilizer application rates will not significantly affect grain crop yields.



(A)



(B)

FIGURE 4. Uniform Soil Surface after Seeding into Stubble: (A) Heavy Trash Cover, (B) Light Trash Cover.



FIGURE 5. Neepawa Wheat 37 Days after Seeding into Summerfallow. Moisture Conditions Slightly Below Average.



FIGURE 6. Patchy Emergence of Neepawa Wheat 42 Days after Seeding Directly in To Hard Stubble with Rows of Heavy Trash. Moisture Conditions Below Average.

Seed Metering System: Large seeds such as wheat, oats and barley and small seeds such as rapeseed are metered through the seed cup using either the high or low speed grain drive.

Seed metering system accuracy was very good in wheat, barley

and oats and good in rapeseed. The manufacturer's calibration charts for wheat and barley were the same as the Machinery Institute's calibrations. Some differences were obtained between the manufacturer's calibrations and the Machinery Institute's calibrations for oats and rapeseed (FIGURE 8 and 9) when using the low speed grain drive. The seed rates shown for each setting must be doubled when the high speed drive is used. Differences in seeding rates will occur when using seed of different size, density and moisture content or when operating at different widths of cut. To obtain exact seeding rates, it is important to adjust for different seed properties and widths of cut.

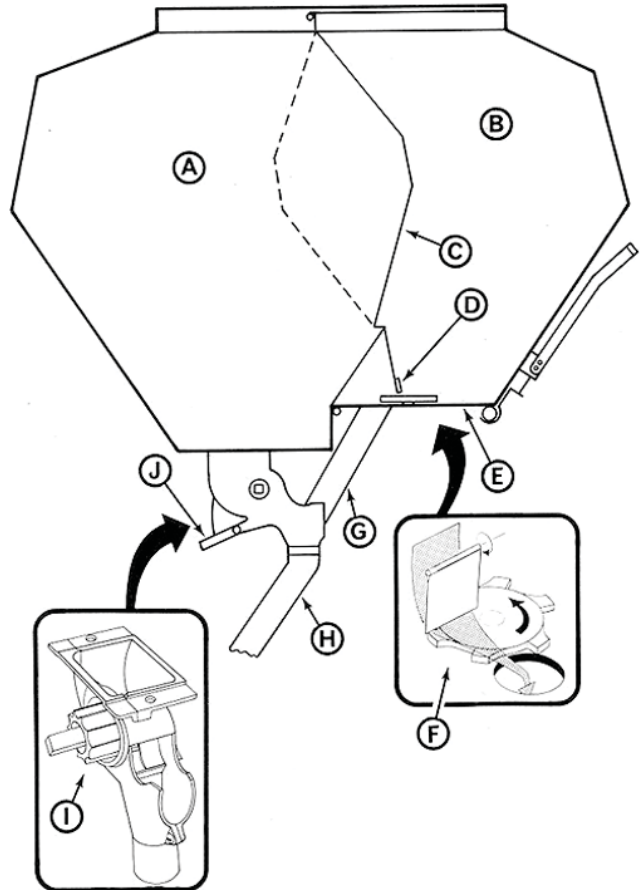

FIGURE 7. Seed and Fertilizer Metering System: (A) Grain Box, (B) Fertilizer Box, (C) Two Position Box Partition, (D) Adjustable Fertilizer Feed Gate, (E) Fertilizer Cleanout Panel, (F) Star Shaped Fertilizer Wheel, (G) Fertilizer Spout, (H) Grain and Fertilizer Drop Tube, (I) Externally Fluted Feedroll, (J) Adjustable Seed Cup Feed Gate.

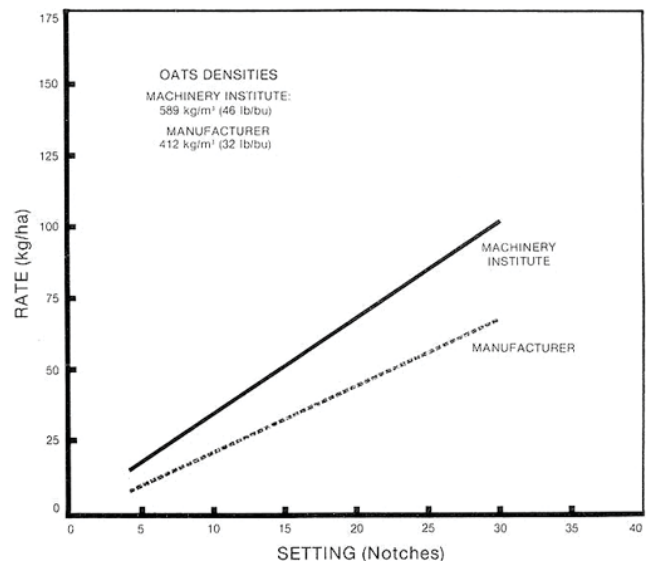

FIGURE 8. Oats Calibration Using the Low Speed Drive.

Field roughness, depth of seed in the grain box, variation in

field slope or ground speed did not affect the seeding rate for either large or small seeds.

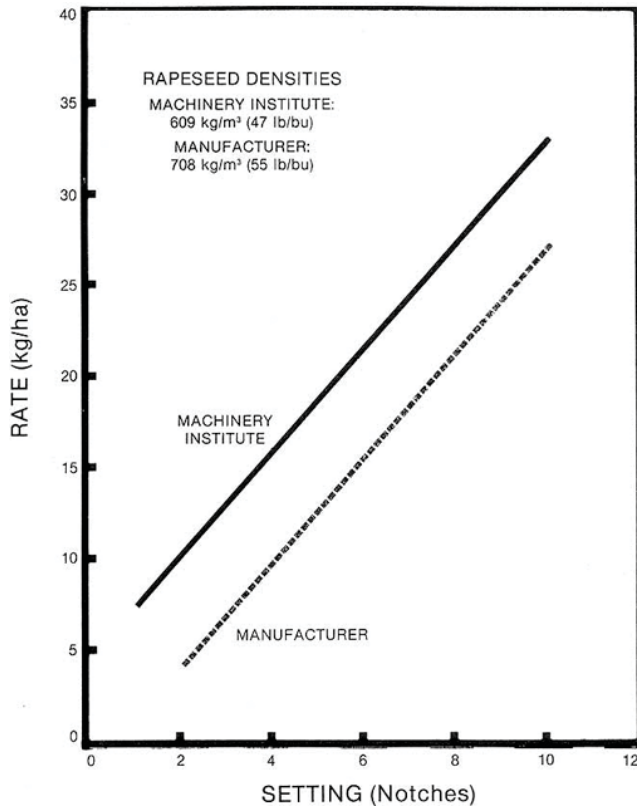

FIGURE 9. Rapeseed Calibration Using the Low Speed Drive.

The coefficient of variation² (CV) is commonly used to describe the variation of the application rate among individual seed cups. An accepted variation for grain or fertilizer application is a CV value not greater than 15%. If the CV is less than 15%, seeding is acceptable, whereas if the CV is much greater than 15%, the variation among individual seed cups is excessive.

For wheat, oats and barley, seeding was very uniform. For example, when seeding wheat at 85 kg/ha (75 lb/ac), the CV was only 2%. When seeding rapeseed at a rate of 7.0 kg/ha (6.2 lb/ac), the CV was 8%.

Fertilizer Metering System: Fertilizer metering accuracy was very good. Comparison of the manufacturer's calibrations with the Machinery Institute's calibrations, showed a significant difference when using the high speed drive (FIGURE 10), but a negligible difference when using the low speed drive. Differences in fertilizing rates will occur when using fertilizer of different size, density and moisture content or when operating at different widths of cut. To obtain exact fertilizing rates, it is important to adjust for different fertilizer properties and widths of cut.

The variation in the fertilizing rate from one run to another was very good. For example, when distributing 11-51-0 fertilizer at a rate of 56 kg/ha (50 lb/ac), the CV among individual feed cups was only 4%.

The fertilizer application rate was not significantly affected by level of fertilizer in the box, field roughness, ground speed, or machine side slope. It was slightly affected by uphill and downhill slopes. FIGURE 11 shows the variation in application rates obtained when fertilizing uphill, downhill and on level ground. The application rate at one setting, while using the high speed drive, varied from 50 kg/ha (45 lb/ac) when seeding up a 15° slope to 63 kg/ha (56 lb/ac) when seeding down a 15° slope.

Grass Seeding: FIGURE 12 presents the Machinery Institute calibration for alfalfa, obtained by seeding with the low speed drive. When using the high speed drive, seeding rates for each setting must be doubled. The graph is presented for operator information only, since this calibration was not given in the operator's manual.

Large light seeds such as bromegrass and ryegrass bridged

over the seed cup openings and prevented the seed from being metered. Large light seeds can usually be metered by mixing the seed with heavier material such as cracked grain or fertilizer.

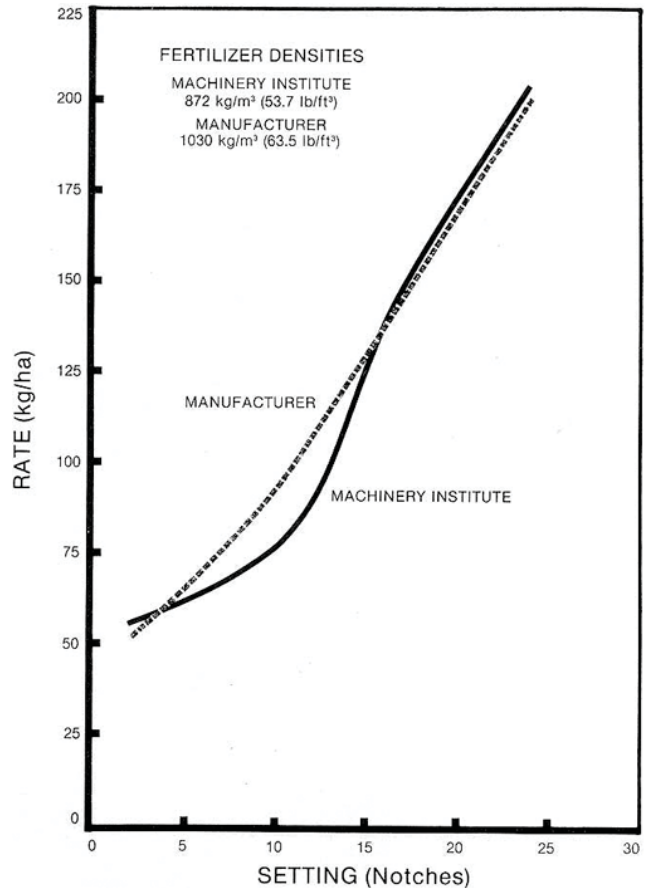

FIGURE 10. Fertilizer Calibration Using the High Speed Drive.

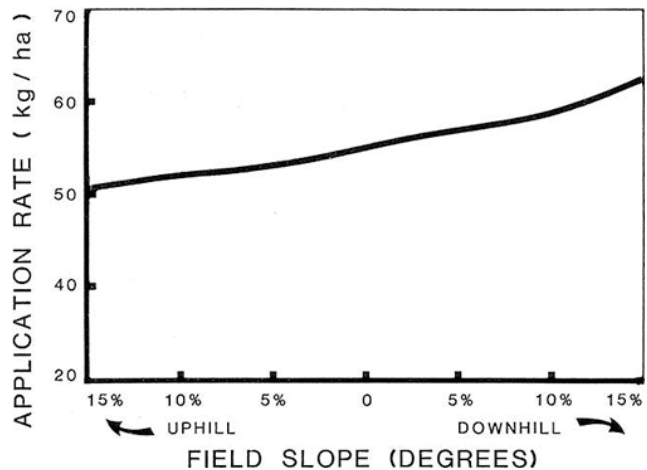

FIGURE 11. Variation in Fertilizer Application Rate with Change in Fore-and-Aft Slope while Applying 11-51-0 Fertilizer at the Number 2 Lever Setting using the High Speed Drive.

EASE OF OPERATION

Wet Fields: Mud buildup on the disks and loose trash occasionally caused disk plugging in wet fields. Plugging occurred more readily in heavy trash areas where bunched straw was pushed ahead of the gangs.

The trash bars reduced the buildup of trash, but did not prevent mud from clinging to the disks. In moist conditions, mud and trash collected between the disks and the disk gang arms and caused plugging (FIGURE 13). The optional disk scrapers effectively reduced mud buildup in moist soils, but did not completely prevent plugging in wet soils. As is common with most one-way disk harrows, plugging occurred more readily at reduced widths of cut and at increased working depths.

Stony Fields: Small 180 to 230 mm (7 to 9 in) diameter rocks

²The coefficient of variation is the standard deviation of application rates from individual seed cups expressed as a percent of the mean application rate.
Page 6

sometimes lodged between adjacent disks in stony fields. Trash bars eliminated lodging of most rocks except for those that wedged tightly between the disks, and jammed against the trash bars to stop gang rotation. Small stones occasionally jammed between the disks and the disk gang arms or seed tube holders to stop gang rotation (FIGURE 14). Occasionally, larger surface rocks were pushed ahead by the disks until plugging occurred.

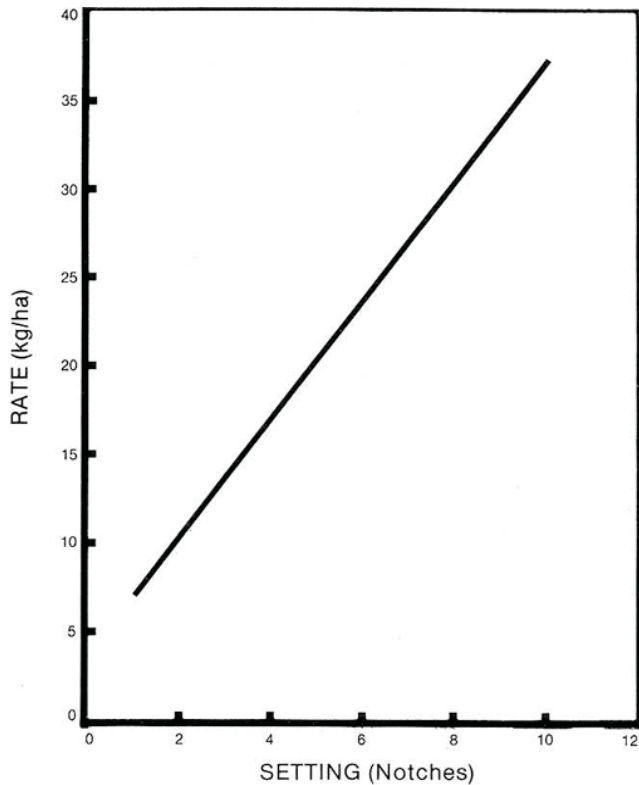

FIGURE 12. Alfalfa Calibration Using the Low Speed Drive Grain Density - 719 kg/m³ (56 lb/bu).



FIGURE 13. Trash and Mud Buildup Between the Disks and the Disk Gang Arm.



FIGURE 14. Small Rock Jammed Between the Disk and Disk Gang Arm.

The spring loaded disk gangs could lift a maximum of 330 mm (13 in) to clear rocks and other obstructions. Disk gang force at maximum trip clearance varied from 3300 to 5250 N (725 to 1155 lb) depending upon the disk gang location. Under normal operating conditions, the disks rode smoothly over rocks and other obstructions without serious damage.

Trashy Fields: Heavy surface trash caused poor disk penetration, poor seed placement and occasional plugging. Plugging occurred when loose clumps of straw and trash were pushed ahead of the disk gangs. Plugging due to trash was more frequent in wet fields than in firm, dry fields. Thistles frequently caught the bottom of the trash bars and built up between the trash bars and the spools.

Changing Disks: The disk gangs were difficult to remove. Four bolts had to be removed from the disk gang arms and two bolts from each adjacent disk gang arm. Two people were required to spread the gangs to separate the ball and socket joints and pull the gang clear of the disk gang arms. One nut with a metal locking tab tightened the disks on the disk gang arbor bolt. Once removed, the disks were easily replaced. New disks should be installed at the rear of the disk gang to maintain uniform penetration.

Filling: Two lids for each unit covered both the grain and fertilizer compartments. Metal strips that prevented grain from falling through or collecting on the hinges when the lids were open, occasionally jammed to prevent the lid from closing. It is recommended that the manufacturer modify the lid to prevent binding of the lid when closing.

Interior fertilizer covers prevented the grain and fertilizer from being mixed when filling. However, some fertilizer leaked through the lid hinges into the grain box. The boxes could be filled only from the front since the lids could not be reversed. A walkway was provided at the front of the machine for easy access. The walkway did not extend beyond the land wheel, making it difficult to reach the end of the box while filling. The partition between the grain and fertilizer boxes (FIGURE 7) could be set in two positions to suit application rates, thereby minimizing downtime for filling. This permitted carrying 2400 L (66 bu) of grain and 1365 kg (3005 lb) of fertilizer or 1905 L (52 bu) of grain and 1865 kg (4108 lb) of fertilizer. Grain and fertilizer level indicators were not provided.

Moisture: The grain box was adequately sealed to prevent moisture from entering during a light rain, but during a heavy rain, moisture entered through a seam at the bottom and back of the grain box. In a light rain, moisture entered the fertilizer box at the corners of the swing down bottoms. If the disk harrow was allowed to stand out in the rain, the fertilizer shafts should be checked before operation to ensure that they rotate freely and that the fertilizer has not caked.

Cleaning: The grain box lid opened wide permitting easy access for cleaning with a brush or vacuum cleaner. The grain box opening was too small to allow access of a 20 L (5 gal) pail. The fertilizer box was easily cleaned by unlatching and swinging down the bottom of the fertilizer box. About 25 kg (55 lb) of fertilizer could not be metered from the fertilizer box. Visibility and access into the bottom of the fertilizer box were very good.

Acremetre: The International Harvester 310 was equipped with an acremetre that recorded the nearest tenth acre up to 1000 acres. The accuracy of the acremetre depended upon the width of cut. A metric counter was not available.

Turning: Left 90° turns were easily made. Sharp left turns greater than 90° caused excessive skidding of the rear land wheel (FIGURE 15). Tilled corners were smooth and could easily be covered by two passes when finishing the field. Sharp right turns had to be made with caution due to interference between the tractor tire and the front unit. When making right turns, the gangs should be raised to reduce draft and prevent possible disk damage in stony fields.

Transporting: The International Harvester 310 could be safely transported at speeds up to 25 km/h (16 mph) when in full transport position, providing the seed and fertilizer boxes were empty. It could be put into or taken out of full transport position by one man in about 10 minutes. Transport width was narrow enough to allow most vehicles to pass on secondary roads (FIGURE 16). When making a right turn to put the machine into transport, it was important that the disks be in the ground to prevent the steering arm of the rear unit from hitting the rear furrow wheel of the front unit (FIGURE 17). A jack was needed for adjusting the hitch and for hitching to the tractor.

It is recommended that the manufacturer supply a jack for the main hitch. A lock was not provided to prevent the disk gangs from lowering during transport. It is recommended that the manufacturer provide a transport lock for the disk gangs.



FIGURE 15. Skidding of the Rear Land Wheel when Making Sharp Left Turns.



FIGURE 16. Full Transport Position.



FIGURE 17. Interference Between Furrow Wheel Steering Arm and Rear Furrow Wheel when Placing into Full Transport with the Disk Gangs Raised.

The International Harvester 310 could be safely transported at speeds up to 18 km/h (11 mph) when in semi-transport position (FIGURE 18). Semi-transport speed was reduced in soft fields due to instability of the front furrow wheels. Semi-transport width was only slightly wider than full transport width, making transport on secondary roads safe and easy. The IH 310 could be placed into or taken out of semi-transport by one person in three minutes. Right or left turns were easily made in semi-transport.



FIGURE 18. Semi-Transport Position.

EASE OF ADJUSTMENT

Width of Cut: The width of cut was adjustable from 7.9 to 9.8 m (26 to 32 ft) depending upon soil conditions, operating depth

and ground speed. The width of cut was adjusted by removing two bolts and adjusting the angle between the main frame and rear furrow wheel subframe for each unit. A jack was required to reposition the rear furrow wheel subframes. Large adjustments also required adjusting the rear furrow wheels to make the two units parallel and setting the lead on the front furrow wheels and land wheels. The range of the rear furrow wheel lead adjustment of the rear unit was insufficient to set the two units parallel at the narrow widths of cut. It is recommended that the manufacturer increase the lead adjustment range of the rear furrow wheel. All other adjustments were adequate to provide the desired range of cutting widths. The amount of cut of the front disk of the rear unit was adjusted by setting the lead of the front furrow wheel on the rear unit.

Tillage Depth: The depth of tillage was determined by the position of the hydraulic cylinder on each unit and by the tension of the disk gang springs. The hydraulic cylinders were easily adjusted from the tractor. An adjustable stop on the cylinders aided in setting the desired depth.

It was very important that the spring force on the disk gangs be properly adjusted to prevent uneven penetration (FIGURE 19). The spring force on the front disk gang had to be adjusted for each working depth and field condition. The spring force on the rear gang required little adjustment once it had been set for operating in very hard soils. The spring force was easily adjusted on the front gang, but was difficult to adjust on the rear gang as it required the removal of the spring rod from the disk gang arm. Also, the range of spring force adjustment for the rear gang was inadequate for some of the soil conditions encountered. It is recommended that the manufacturer modify the rear disk gang spring adjustment to simplify and increase the range and convenience of adjustment.

Individual unit frames were easily levelled with levelling screws at the front of each unit. Depth indicators for initial setting of the hydraulic cylinders were not provided.

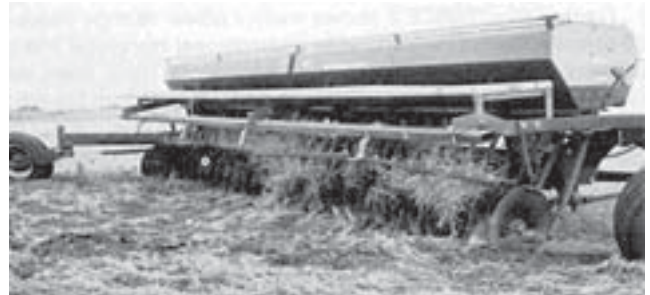

FIGURE 19. Uneven Penetration in Hard Soils Due to Improper Adjustment of Disk Gang Springs.

Lubrication: Seventy pressure grease fittings required greasing and the grain metering clutch required oiling every 10 hours of operation. Twenty-six fittings required greasing every 50 hours. The wheel bearings are to be cleaned and repacked with grease and the telescoping grain drive shaft is to be extended and greased each season. Daily lubrication took at least 30 minutes. The fertilizer shaft frequently had to be rotated to obtain access to the two fertilizer spur gear grease fittings on each unit. All other lubrication points were readily accessible.

Seeding and Fertilizing Rates: Seeding and fertilizing rates were easily adjusted. To set the seeding rate, the operator's manual stated that the rate selection lever be moved slightly past the desired setting and then brought back slowly until the edge was directly on the setting. To set the fertilizing rate, the selection lever was moved to the desired setting. To change the grain or fertilizer drive from the high to the tow speed range, a sprocket on the main shaft was changed and the drive chain shortened. Each seed cup and fertilizer gate should be adjusted according to the operator's manual before seeding.

POWER REQUIREMENTS

Draft Characteristics: FIGURE 20 shows draft requirements for one-way disk harrows in typical primary tillage at a speed of 8 km/h (5 mph). This figure gives average requirements based on tests of eleven machines in 36 different field conditions.

It is impossible to make meaningful comparisons of the draft requirements of different makes of one-way disk harrows. Draft

requirements for the same one-way disk harrows, in the same field, may vary by as much as 30% in two different years due to changes in soil conditions. Variation in soil conditions affect draft much more than variation in machine make, usually making it impossible to measure any significant draft differences between different makes of one-way disk harrows. The difficulty in accurately measuring and controlling the depth of tillage, which directly affects draft requirements, further complicates direct draft comparisons.

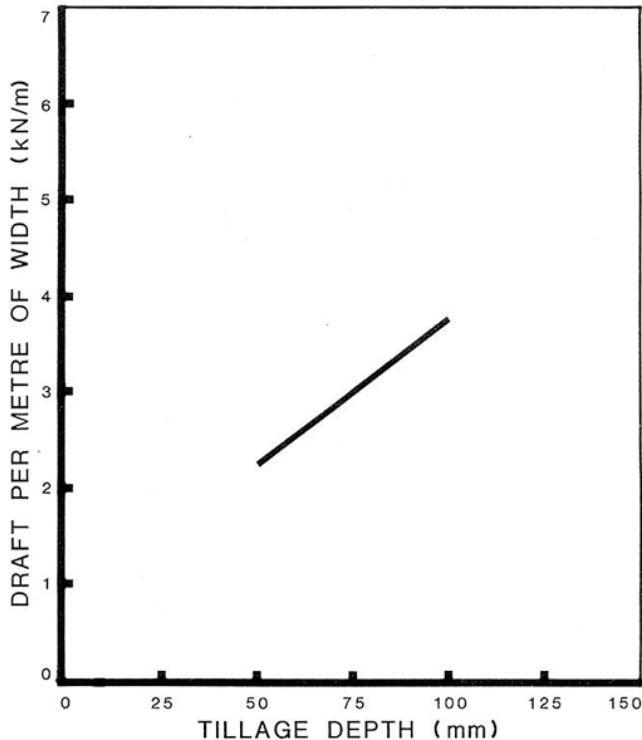

FIGURE 20. Average Draft Requirements for One-Way Disk Harrows at 8 km/h.

In primary tillage, average draft at 8 km/h (5 mph), varied from 2.2 kN/m (147 lb/ft) of width at 50 mm (2 in) depth to 3.5 kN/m (235 lb/ft) of width at 90 mm (3.5 in) depths. This represents a total draft from 21.5 to 34.3 kN (4800 to 7466 lb) for the 9.8 m (32 ft) test machine.

Increasing speed by 1 km/h, increased draft by about 134 N/m of width (a draft increase of 14 lb/ft of width for a 1 mph speed increase). For the 9.8 m (32 ft) wide test machine, this represents a draft increase of 1.31 kN (4800 to 7466 lb) for a 1 km/h speed increase (459 lb for a 1 mph speed increase).

Tractor Size: TABLE 2 shows tractor power ratings needed to operate the 9.8 m (32 ft) wide International Harvester 310 in primary tillage. Tractor power requirements have been adjusted to include tractive efficiency and are based on the tractor operating at 80% of maximum power on a level field. The tractor sizes presented in the table are the maximum power take-off rating, as determined by Nebraska tests or as presented by the tractor manufacturer. Tractors selected according to this table will have ample power reserve to operate the International Harvester 310 in primary tillage.

Tractor size may be determined from TABLE 2 by selecting the desired tillage depth and speed. For example, at a depth of 75 mm (3 in) and a speed of 8 km/h (5 mph), a 103 kW (139 hp) tractor is needed to operate the International Harvester 310.

TABLE 2. Tractor Size (Maximum Power Take-Off Rating, kW) to Operate the 9.8 m Wide International Harvester 310 in Primary Tillage

| Depth | Speed | | | | | |
|-------|-------|----|-----|-----|-----|-----|
| | 5 | 6 | 7 | 8 | 9 | 10 |
| 50 | 39 | 51 | 63 | 77 | 91 | 107 |
| 75 | 56 | 70 | 86 | 103 | 121 | 140 |
| 89 | 65 | 82 | 99 | 118 | 138 | 158 |
| 100 | 72 | 90 | 109 | 129 | 151 | 173 |

OPERATOR SAFETY

The International Harvester 310 was safe to operate if normal safety precautions were observed.

The front furrow wheels and land wheels exceeded the Tire and Rim Association maximum ratings up to 40% and 23% respectively when operating in the field with full grain and fertilizer boxes. No overload occurred with empty, boxes. The front furrow wheels, land wheels and rear furrow wheels were overloaded up to 64%, 45% and 67% respectively when transporting with full boxes at speeds above 16 km/h (10 mph). There was only slight overload on the rear furrow wheel when transporting with empty boxes.

A slow moving vehicle sign was not provided for the disk harrow, although a mounting bracket for a sign was provided. It is recommended that a slow moving vehicle sign be provided as standard equipment.

OPERATOR'S MANUAL

The operator's manual was well written and illustrated, and provided adequate information on operation and maintenance of the machine. Both English and Metric calibration charts were included in the operator's manual. The operator's manual did not include adjustments for setting the units parallel, adjusting the rear disk gang force or setting the cut of the front disk of the rear unit. It is recommended that the manufacturer include information on these adjustments in the operator's manual.

DURABILITY RESULTS

The International Harvester 310 was operated for 85 hours while tilling about 434 ha (1070 acres). The intent of the test was to evaluate the functional performance of the machine, and an extended durability evaluation was not conducted. TABLE 3 outlines the mechanical problems that occurred during the functional testing.

TABLE 3. Mechanical History

| Item | Operating Hours | Equivalent Field Area ha |
|---|-----------------|--------------------------|
| -The set screw on the fertilizer drive gear came loose, disengaging the fertilizer shaft at | 10 | 48 |
| -The main hitch brace buckled and was straightened at | 17, 19 | 72, 85 |
| -The tire of the front furrow wheel of the rear unit came off its rim and was replaced at | 23 | 102 |
| -The fertilizer drive chain came off when the fertilizer bottom was lowered during cleanout at | 45 | 195 |
| -One seed tube and holder were cut off when jammed against a disk by mud buildup between the disks. They were replaced at | 72 | 353 |
| -The land wheel pivot arm slipped over the front land wheel lead adjustment block and bent at | 85 | 403 |
| -The arbor bolt of a front disk gang bent and was replaced at | | during the test |
| -Seed tubes occasionally bent out of position when raising and lowering the gangs | | during the test |
| -One disk was bent, and one disk and one spool were broken | | during the test |

DISCUSSION OF MECHANICAL PROBLEMS

Hitch Brace: The hitch brace buckled twice when making sharp right turns with the disks raised (FIGURE 21). The exterior rectangular tubing of the telescoping hitch brace was extended 279 mm (11 in) and no further buckling occurred. It is recommended that the manufacturer modify the hitch brace to eliminate buckling on sharp right turns.



FIGURE 21. Buckled Hitch Brace.

Seed Drop Tubes: Seed tubes would bind in the tube holder and bend when the disks were fully raised. Occasionally, these tubes failed to return to their original position when the gangs were

lowered. It is recommended that the manufacturer modify the tube holders to prevent seed drop tubes from bending when raising and lowering the gangs.

Tire: The tire was forced off the rim due to skidding of the front furrow wheel when making a sharp right turn with the gangs raised and the grain and fertilizer boxes full.

Land Wheel Arm: The land wheel pivot arm slipped over the lead adjustment block when the land wheel fell into a large hole. The steering link was bent when the gangs were raised with the pivot arm out of position. The steering link and pivot arm were straightened and no further problems occurred.

Disks: One front disk and adjacent spool broke while operating in a stony field. Only a few disks were slightly nicked, and were still suitable for resharpening.

APPENDIX I SPECIFICATIONS

| | | | |
|------------------------------------|--|-----------------------|------------------|
| MAKE: | International Harvester Diskall | | |
| MODEL: | 310 | | |
| SERIAL NUMBER: | | | |
| -- front unit | 10008550001067.80 | | |
| -- rear unit | 1000855C001669.80 | | |
| HITCH CONFIGURATION: | | | |
| -- number of units | 2 | | |
| -- hitch type | tandem | | |
| OVERALL DIMENSIONS: | Field | Semi-Transport | Transport |
| -- height | 1400 mm | 1400 mm | 1425 mm |
| -- width | 9900 mm | 5660 mm | 4790 mm |
| -- ground clearance | 230 mm | 230 mm | 200 mm |
| -- nominal seeding width | 9754 mm | | |
| SEED METERING SYSTEM: | | | |
| -- type | externally fluted feed rolls | | |
| -- drive | chain driven from land wheel | | |
| -- adjustment | lever controlling feed roll protrusion into seed cup | | |
| -- transfers to openers | rubber tubes | | |
| FERTILIZER METERING SYSTEM: | | | |
| -- type | star-shaped feed wheel rotating on vertical shaft | | |
| -- drive | chain and gear drive from land wheel | | |
| -- adjustment | lever controlling feed inlet size | | |
| -- transfer to openers | rubber funnel to top of seed tube | | |
| DISK GANGS: | | | |
| -- number of disks per unit | 32 | | |
| -- number of gangs per unit | 4 | | |
| -- number of disks per gang | 8 | | |
| -- disk diameter | 508 mm | | |
| -- disk thickness | 4.7 mm (6 gauge) | | |
| -- disk concavity | 58 mm | | |
| -- disk spacing | 178 mm | | |

TIRES:

| | |
|-----------|--|
| -- number | 6 |
| -- size | 4, 11L x 15, 6-ply 1, 7.60 x 15, 6-ply 1, 5.90 x 15, 6-ply |

GRAIN AND FERTILIZER BOX CAPACITIES:

| | | |
|----------------------------|---------|---------|
| -- grain box capacity | 2400 L | 1935 L |
| -- fertilizer box capacity | 1365 kg | 1865 kg |

WEIGHT:

| | Boxes Empty | Boxes Full |
|-------------------------------|--------------------|-------------------|
| -- front unit | | |
| -weight on front furrow wheel | 904 kg | 1568 kg |
| -weight on land wheel | 786 kg | 1369 kg |
| -weight on rear furrow wheel | 700 kg | 1040 kg |
| -- rear unit | | |
| -weight on front furrow wheel | 900 kg | 1542 kg |
| -weight on land wheel | 745 kg | 1384 kg |
| -weight on rear furrow wheel | 695 kg | 1008 kg |
| Total | 4730kg | 7911 kg |

LUBRICATION POINTS:

| | |
|--------------------------------------|---------------------------------|
| -- 10h | 70 pressure grease fittings |
| -- 10h | oil grain metering drive clutch |
| -- 50 h | 26 pressure grease fittings |
| -- remove, clean and oil when needed | 12 drive chains |
| -- seasonal | wheel bearings |
| -- 9 grease periodically | telescoping grain drive shaft |

NUMBER OF CHAIN DRIVES:

12

NUMBER OF HYDRAULIC LIFTS:

2

NUMBER OF SEALED BEARINGS:

5

APPENDIX II MACHINE RATINGS

The following rating scale is used in Machinery Institute Evaluation Reports:

| | |
|--------------|-------------------|
| a) excellent | d) fair |
| b) very good | e) poor |
| c) good | f) unsatisfactory |

APPENDIX III CONVERSION TABLE

| | |
|----------------------------|---------------------------|
| 1 kilometre/hour (km/h) | = 0.6 miles/hour (mph) |
| 1 metre (m) | = 3.3 feet (ft) |
| 1 millimetre (mm) | = 0.04 inches (in) |
| 1 kilogram (kg) | = 2.2 pounds mass (lb) |
| 1 kilowatt (kW) | = 1.3 horsepower (hp) |
| 1 hectare (ha) | = 2.5 acres (ac) |
| 1 litre (L) | = 0.03 bushels (bu) |
| 1 newton (N) | = 0.2 pounds force (lb) |
| 1 kilonewton (kN) | = 220 pounds force (lb) |
| 1 kilogram/hectare (kg/ha) | = 0.9 pounds/acre (lb/ac) |



3000 College Drive South
Lethbridge, Alberta, Canada T1K 1L6
Telephone: (403) 329-1212
FAX: (403) 329-5562
<http://www.agric.gov.ab.ca/navigation/engineering/afmrc/index.html>

Prairie Agricultural Machinery Institute

Head Office: P.O. Box 1900, Humboldt, Saskatchewan, Canada S0K 2A0
Telephone: (306) 682-2555

Test Stations:

P.O. Box 1060
Portage la Prairie, Manitoba, Canada R1N 3C5
Telephone: (204) 239-5445
Fax: (204) 239-7124

P.O. Box 1150
Humboldt, Saskatchewan, Canada S0K 2A0
Telephone: (306) 682-5033
Fax: (306) 682-5080