

Evaluation Report

94

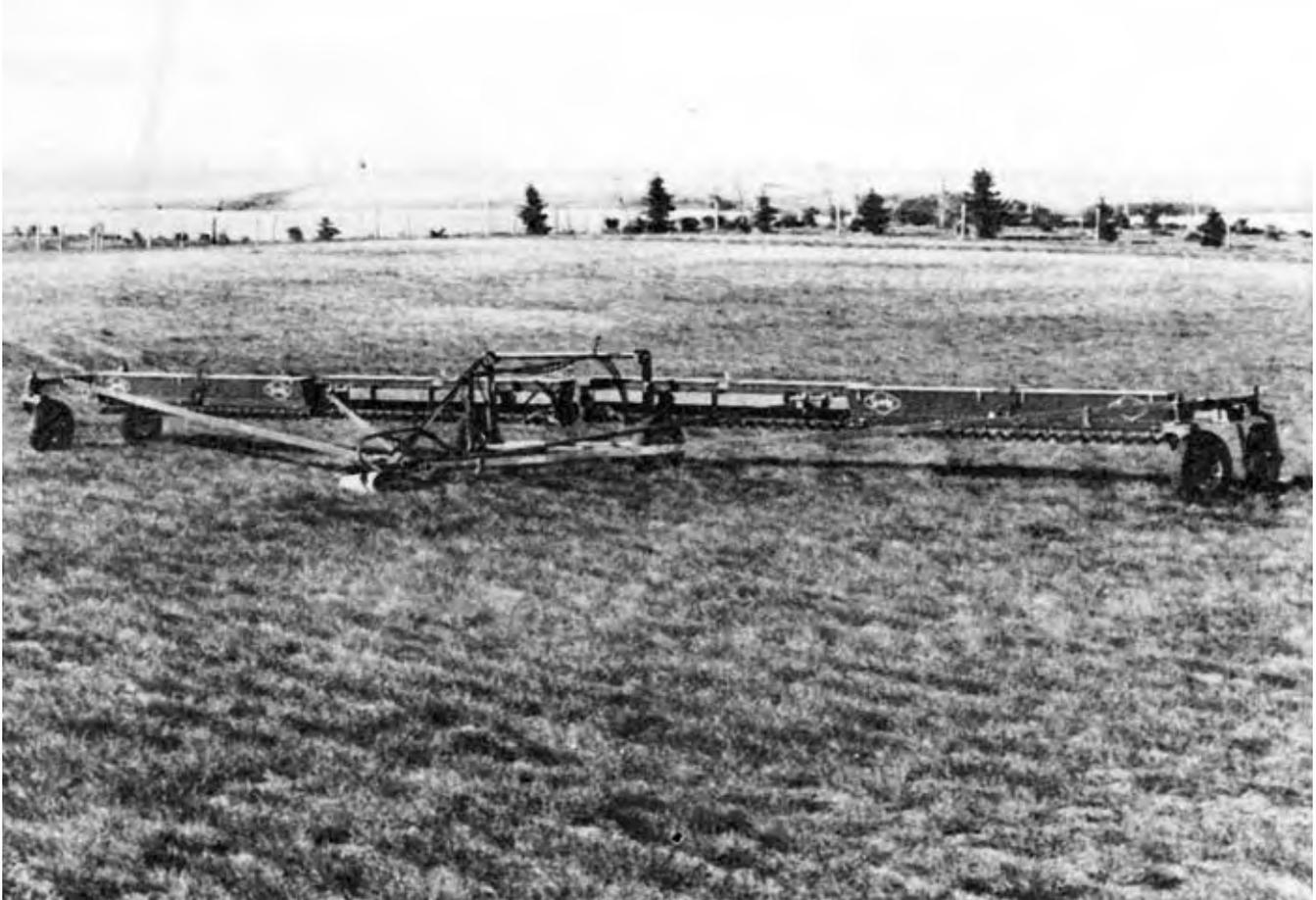

Gandy Model 448-8SNF Granular Applicator

A Co-operative Program Between



GANDY MODEL 448-8SNF GRANULAR APPLICATOR

MANUFACTURER:
Gandy Company Manufacturers
528 Gandrud Road
Owatonna, Minnesota 55060
U.S.A.

DISTRIBUTOR:
Pender Seed Division Limited
Box 130
Meath Park, Saskatchewan
S0J 1T0

RETAIL PRICE:
\$6975.00 (May, 1978, f.o.b. Lethbridge, Alberta).

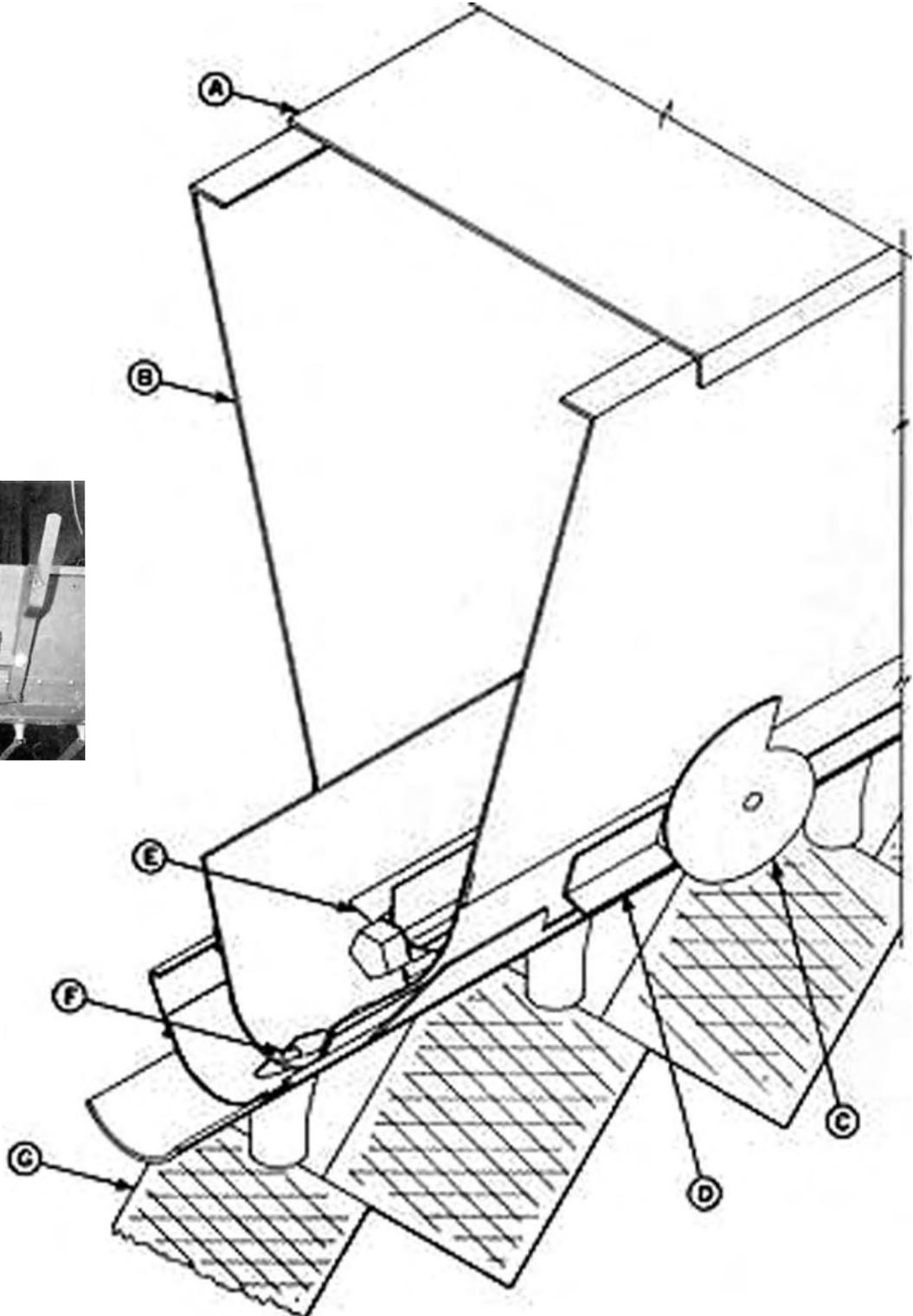
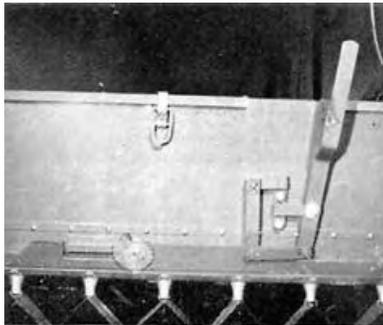

FIGURE 1. Schematic View of Gandy Granular Applicator: (A) Hopper Lid, (B) Hopper, (C) Cam Gauge, (D) Cam Gauge Stop Bracket, (E) Feed Rotor, (F) Adjustable Orifice, (G) Expanded Metal Deflector.

SUMMARY AND CONCLUSIONS

Overall functional performance of the Gandy Model 448-SSNF granular applicator was fair. Metering uniformity of individual hoppers was very good while distribution of granules on the soil surface was fair. Functional performance was reduced by calibration variation among hoppers and difficulty to accurately set application rate. Durability of the Gandy, during functional testing, was very good.

The Gandy had sufficient range of adjustment to suit recommended application rates for both granular Avadex BW and granular Treflan. The manufacturer's calibration chart was accurate for only one of the hoppers and the chart read high for the remaining three. Calibration variation among hoppers was 6 kg/ha (5 lb/ac) at 9 km/h (5.6 mph) at normal Avadex BW application rates. All hoppers could be set for uniform application, but each had to be individually calibrated and adjusted. Application rates were not affected by field roughness, level of granules in the hopper, or fore and aft slope, but were slightly affected by sideways field slope. Rotor speeds from 15 to 50 rpm had no effect on application rate but ground speed directly affected application rate.

Although the metering of granules from the orifices was very uniform across the width of each hopper, with a coefficient of variation of only 4%, the distribution of granules on the ground was less uniform, resulting in a coefficient of variation of about 27%. Application rate in the direction of travel also varied, since the output from the orifices decreased as the rotor fins passed by the orifices. Thorough soil incorporation was necessary to get uniform distribution due to the variation in application across the spreading width and in the direction of travel.

The Gandy applicator performed well on hilly fields. Maximum field capacity was about 18 ha/h (44 ac/h). Field capacity was reduced on hard rough fields, as slower speeds were required to prevent bouncing. The hopper held about 455 kg (1000 lb) of Avadex BW, which was sufficient to cover about 30 ha (75 ac), at common application rates, without filling. The hopper lids were not weather tight, allowing rain to leak into the hoppers. Hoppers were of suitable height for easy filling from the ground. The hoppers emptied completely in the field. Removal of the rotors and drives, for thorough cleaning, took about two hours.

Hopper settings were conveniently adjusted, but accurate application rates were difficult to achieve. Small adjustments of the cam gauge resulted in large changes in application rate and the calibration of each hopper was different. This, combined with changes in application rates, resulting from changes in forward speed, made accurate setting of application rates difficult.

The Gandy was convenient to operate and was fairly easy to fold into transport or field position, taking one man about 10 minutes. The end wheels left tracks in the field to aid lining up successive field passes. Granules falling on the field could not be seen from the tractor seat, however, rotation of the feed rotors could be observed. Drives for the two applicator halves could be separately engaged or disengaged from the tractor.

Hitching was convenient. Either open or closed centre tractor hydraulic systems could be used. Towing and turning in transport was convenient while backing in transport was awkward.

A few minor mechanical problems occurred during the test. A bearing lock collar loosened, bending a castor wheel fork. One hopper leaked granules. The rotor drive chains were overloaded and broke several times during the test.

RECOMMENDATIONS

It is recommended that the manufacturer consider:

1. Modifications so all hoppers can be conveniently set for uniform and accurate application rates.
2. Investigating the possibility of making application rate independent of forward speed to improve ease of calibration.
3. Investigating modifications to the deflectors to improve distribution of granules on the soil surface.
4. Modifications to make the hopper lids weather tight.
5. Modifications to prevent frequent drive chain failure.
6. Supplying a slow moving vehicle sign.
7. Modifying the calibration charts to include a wider range

of application rates and more explicit instructions so that application rate is not confused with cam gauge setting.

8. Preparing the operator's manual in both English and SI units.

Chief Engineer - E. O. Nyborg

Senior Engineer - E. H. Wiens

Project Engineer - K. W. Drever

THE MANUFACTURER STATES THAT:

With regard to recommendation number:

1. The cam gauge controls the slide movement to vary the metering opening size, which determines flow rate. Opening size can also be affected by the position of the slide, forward or backward of its centre position. To check, set the cam gauge at 20 or 40 and open the slide to that point. The diamond shaped holes should be symmetrical (i.e. the two side corners should be directly across from one another). If they are not, the opening area and flow rate will be lower than the rate charts indicate. To correct, pull the slide toward the cam gauge side of the hopper until the holes are symmetrical. Possible causes of the holes not being symmetrical are damage during shipping, insufficient clips holding the slide in place (12 ft hoppers should have 7, 10 ft and 8 ft should have 5 clips), or foreign material between the slide and hanger or slide and bottom.
2. This recommendation will be investigated.
3. We have been constantly investigating a better deflector system. The expanded metal deflector is a Canadian innovation. Dual spread deflectors or ro-bander attachments are also available.
4. Optional rubber cover gaskets are available to make the hopper lids weather tight.
5. The #32 steel detachable chain has been replaced with 2040 roller chain and appropriate sprockets to prevent chain failure. Conversion packages are available from the distributor.
6. Slow moving vehicle signs are available from the distributor.
7. The calibration chart used was furnished to us by Monsanto Ltd. based on application rates for Avadex BW of 12.5 and 15 lb/ac. No change to the rate chart is anticipated until Monsanto changes their label to include other rates.
8. SI (metric) units will be added at the next reprinting of the operator's manual.

GENERAL DESCRIPTION

The Candy Model 448-8SNF granular applicator is a trailer mounted, dribble type spreader. It consists of four hoppers, with a total capacity of 0.65 m³ (23 ft³). Granules are metered from the hopper bottom through 96 adjustable orifices, spaced at 150 mm (6 in), resulting in a 14.6 m (48 ft) spreading width. Granules are spread by dropping through expanded metal deflectors.

A hydraulic motor on each side of the applicator drives feed rotors in the bottom of each hopper. Stopping the rotors stops application. A flow control valve on each hydraulic motor provides constant rotor speed for different tractor hydraulic systems.

Application rate is controlled by adjusting the orifice opening or the forward speed. Orifice opening size is set with a cam gauge on each hopper.

Each half of the trailer folds back for transporting.

FIGURE 1 shows a schematic view of the hopper while detailed specifications are given in APPENDIX I.

The test machine was trailer mounted. Optional brackets and accessories are available for mounting the hoppers directly on cultivators, discers, or other tillage machines.

SCOPE OF TEST

The Candy Model 448-8SNF granular applicator was operated for 64 hours while applying granular Avadex BW to about 870 ha (2150 ac), and granular Treflan to about 4 ha (10 ac). Field speeds ranged from 8 to 12 km/h (5 to 7.5 mph). The applicator was evaluated for quality of work, ease of operation, operator safety and suitability of the operator's manual. Metering and distribution system accuracy were evaluated in the laboratory with Avadex BW. Standard procedures¹ were used to determine the effect of field and machine variables on metering and distribution.

¹PAMI T772-R78, Detailed Test Procedures for Granular Applicators.

RESULTS AND DISCUSSION

QUALITY OF WORK

Calibration Chart Accuracy: FIGURE 2 compares the manufacturer's calibration for Avadex BW with calibration results obtained for each hopper at 9 km/h (5.6 mph). Only one hopper agreed with the manufacturer's calibration. Delivery of the remaining hoppers was low, with the most inaccurate hopper applying about 6 kg/ha (5 lb/ac) less than indicated. Uniform application was possible only by individual calibration of each hopper and setting each cam gauge accordingly.

Application rates were not affected by field roughness, level of material in the hopper or fore and aft field slope. Application rate was increased slightly by sideways field slope. A typical application rate increase when applying 18 kg/ha (16 lb/ac) at 9 km/h (5.6 mph) on a 5% side slope was 0.6 kg/ha (0.5 lb/ac).

Application rate did not change when the applicator was operated at rotor speeds ranging from 15 to 50 rpm. Rotor speeds less than 15 rpm caused a large increase in application. For example, slowing the rotor to 7 rpm caused a 5 kg/ha (4 lb/ac) increase when applying 20 kg/ha (18 lb/ac) at 9 km/h (5.6 mph). The operator's manual recommends a 25 rpm rotor speed which is a suitable rotor speed for consistent calibration accuracy.

Forward speed affected application rates since delivery from the orifices was constant for a given cam gauge setting. Higher application occurred at low speeds and lower application at high speeds. Constant ground speed was necessary for uniform application.

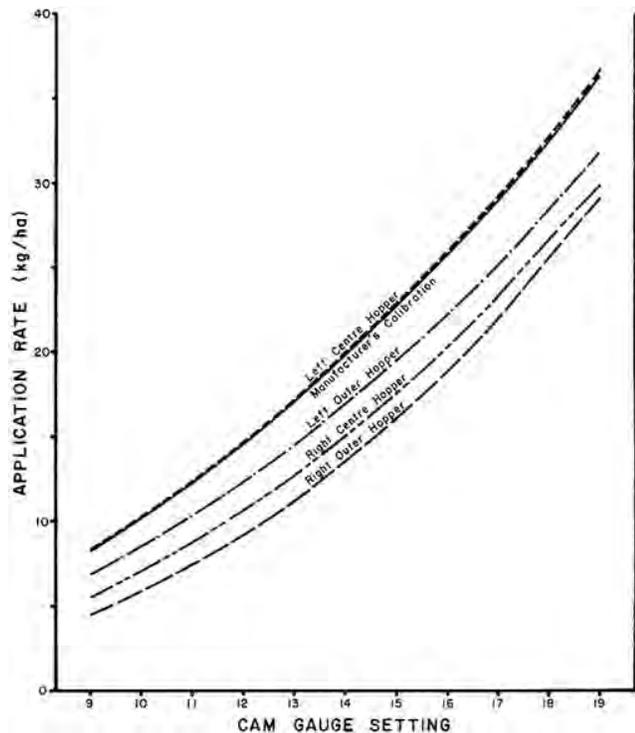

FIGURE 2. Calibration Curves for Avadex BW at 9 km/h (5.6 mph).

Metering Accuracy: FIGURE 3 shows typical delivery rates from 24 adjacent orifices while applying 12.8 kg/ha (11.4 lb/ac) of Avadex BW at 9 km/h (5.6 mph). Application rates from individual orifices varied from 12.0 to 13.7 kg/ha (10.7 to 12.2 lb/ac), resulting in a coefficient of variation² of only 4%. The variability in delivery rates from individual orifices was similar over the normal range of application rates.

Spreading Accuracy: Although metering from the hoppers was very uniform, distribution on the ground was not uniform. Granules metered from the hoppers fell through expanded metal deflectors to reduce banding beneath the orifice. FIGURE 4 shows a typical distribution of Avadex BW granules on the ground under a 1.14 m (45 in) wide section of the applicator, when applying 14

kg/ha (13 lb/ac) at 9 km/h (5.6 mph). Application rates across the applicator section varied from 7 to 22 kg/ha (6 to 20 lb/ac), resulting in a coefficient of variation of about 27%. Similar distribution patterns occurred at all application rates. Although the distribution pattern varied with wind and field roughness, the variation in application across the spreading width indicates that thorough soil incorporation was necessary to get uniform distribution in the soil. Modifications to the deflectors could possibly improve distribution on the soil surface.

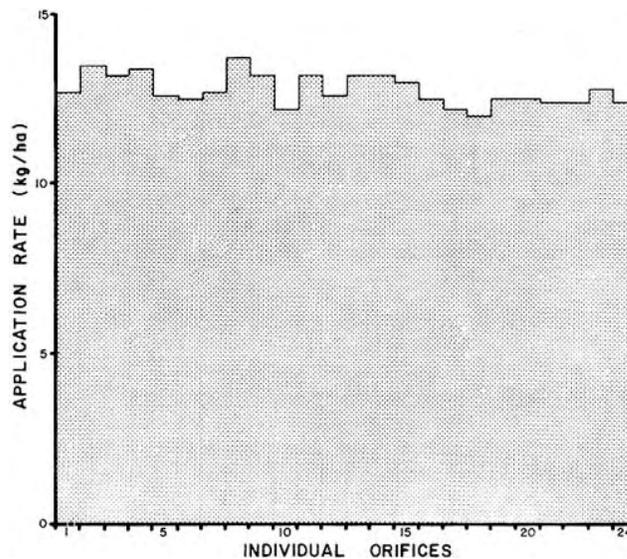

FIGURE 3. Typical Variation in Delivery Rates from Adjacent Orifices in One Hopper.

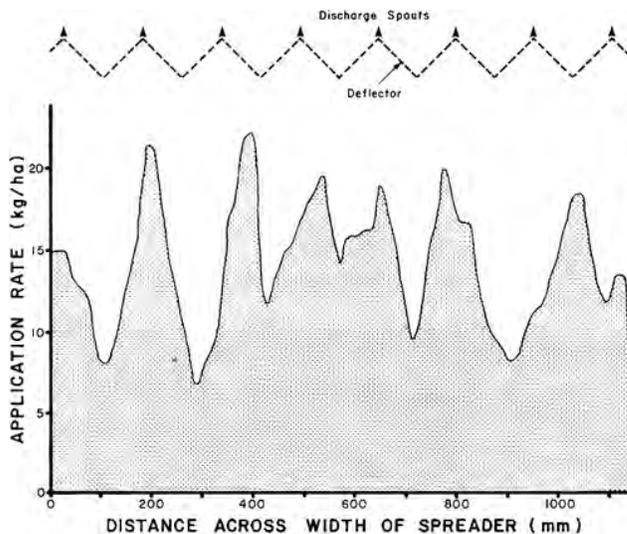

FIGURE 4. Typical Distribution of Avadex BW Granules on the Ground under a 1.14 m (45 in) Wide Section of the Applicator when Applying 14 kg/ha (13 lb/ac) at 9 km/h (5.6 mph).

Distribution of granules also varied slightly in the direction of travel. As each rotor fin passed over the orifices, the orifices were partially blocked and the flow rate was reduced. A typical instantaneous decrease in flow rate was about 30%. At a 25 rpm rotor speed, low application occurred simultaneously across the full width of each hopper every 1200 mm (4 ft) of travel at 9 km/h (5.6 mph).

Calibration with Granular Treflan: Calibration accuracy with granular Treflan was not checked. Field tests indicated there was sufficient cam gauge adjustment to achieve the 28 kg/ha (25 lb/ac) application rate recommended for granular Treflan. Since the filler material used in Treflan granules is similar to the filler material used in Avadex BW, it is expected that performance of both would be similar. Due to different granule densities, calibration curves would be different.

EASE OF OPERATION

Hitching: The Gandy was conveniently hitched to a tractor. A jack was required to lift the hitch tongue.

²The coefficient of variation (CV) is the standard deviation of the application rates, expressed as a percent of the mean application rate. A low CV represents uniform application whereas a high CV indicates non-uniform application. One granular herbicide manufacturer has suggested that the CV should be no greater than 10%.

The two hydraulic motors required a tractor equipped with dual hydraulics unless the hydraulic hoses were modified to connect the motors in series. Oil flow to the hydraulic motors had to be in one direction for open centre hydraulic systems and in the opposite direction for closed centre systems. An optional flow divider package was required to prevent oil overheating when used with open centre hydraulic systems with a pump capacity of more than 1.0 L/s (13 gal/min).

Hoppers: The hoppers were conveniently positioned for filling with bagged granules while standing on the ground.

The hoppers held about 455 kg (1000 lb) of Avadex BW, which was sufficient to cover about 30 ha (75 ac) before refilling, when applying 13.5 kg/ha (12.0 lb/ac).

The hoppers emptied completely while running the applicator in the field. The rotor and drive assembly could be removed to permit a thorough cleaning, taking one man with tools, about two hours.

The hopper lids were not weather tight. Rain entered the hopper (FIGURE 5) dissolving the granules to form a thick paste that would not flow through the orifices. The rotor and drive assembly had to be removed to clean out the paste. Modifications are recommended to prevent rain from entering the hoppers.



FIGURE 5. Thick Paste Formed when Rain Entered Hopper.

Setting the Application Rate: The application rate was adjusted either by changing the cam gauge setting or by changing the ground speed. This was a complicated procedure since tractor forward speed had to be determined and cam gauge settings selected to match the desired application rate at that ground speed. The cam gauge was conveniently adjusted without tools, but precise application was difficult to achieve since a small change in cam gauge setting resulted in a large change in application rate. The cam gauge was adjustable from 0 to 40 in increments of 1 and from 40 to 80 in increments of 5. Cam gauge settings from 12 to 17 were normally used for Avadex BW. Setting the application rate was further complicated since the calibration of each hopper was different (FIGURE 2). Modifications so that all hoppers can be conveniently set for uniform and accurate application rates is recommended. It is also recommended that the manufacturer investigate modifications to make application rate independent of forward speed to improve ease of calibration.

Field Operation: The Gandy applicator was hinged at the centre and operated well on rolling topography. The wheels at the applicator ends were rigid and were not mounted on a walking beam. When crossing gullies all of the applicator weight was carried on the front or rear wheels.

Performance was satisfactory on most fields at speeds up to

12 km/h (7.5 mph), resulting in a maximum field capacity of about 18 ha/h (44 ac/h). Discretion had to be used when selecting forward speed on rough, hard fields to minimize applicator bounce.

The applicator end wheels left tracks that were easy to follow when making successive passes down the field, especially on fields with little trash cover.

Each half of the applicator could be conveniently stopped or started by using the tractor hydraulic controls. This was useful to avoid double application when finishing fields or turning on headlands. Application rate could be changed from the tractor by changing forward speed.

Granules falling from the deflector were not visible from the tractor however rotor drive rotation was visible from the tractor seat and could be used as a field check on distributor operation.

Transporting: The Gandy applicator could be placed into transport or field position by one man in about 10 minutes. No tools were needed. Unfolding the applicator to field position was difficult for one man in soft fields, since the applicator end had to be rocked back and forth in order to line up the pin holes on the radius brace.

The Gandy applicator transported well at normal road speeds. Turning when in transport was convenient but backing in transport was awkward.

Lubrication: The Gandy applicator had 12 grease fittings requiring daily lubrication. All fittings were accessible. The 20 rotor bearings required daily oiling. These were accessible when the hoppers were empty.

OPERATOR SAFETY

The Gandy applicator was safe to operate if normal safety procedures were followed. A slow moving vehicle sign was not provided. It is recommended that a sign be supplied to comply with provincial safety regulations.

OPERATOR'S MANUAL

The operator's manual clearly outlined operating instructions, maintenance, setting up instructions and contained a well illustrated comprehensive parts list.

A calibration chart was attached to the applicator. The calibration chart showed cam gauge settings for only 12.5 and 15.0 lb/ac application rates of Avadex BW at various ground speeds. The calibration chart was in error for some hoppers, since there was considerable calibration variation among hoppers. The calibration chart should be expanded to include settings through a wider range of application rates as well as giving application rates that are accurate for all hoppers.

Operators sometimes confused the cam gauge setting number with application rate. More explicit instructions are required.

The operator's manual and calibration charts were prepared only in English units. It is recommended that they also be prepared using SI (metric) units to facilitate applicator operation after conversion to the SI system.

MECHANICAL PROBLEMS

TABLE 1 outlines the mechanical history of the Gandy Model 448-8SNF granular applicator during 64 hours of field operation while spreading granular herbicides on about 874 ha (2160 ac). The intent of the test was evaluation of functional performance. The following failures represent only those, which occurred during functional testing. An extended durability evaluation was not conducted.

TABLE 1. Mechanical History

Item	Operating Hours	Equivalent Field Area	
		ha	(ac)
Trailer Assembly			
-The bearing lock collar on the right front castor wheel loosened, causing the castor fork to bend. The fork was straightened and the lock collar replaced at	5	68	(169)
-The left inner wheel nuts loosened and were tightened at	6	82	(203)
-The right wheel bracket bolts loosened and were tightened at	22	301	(743)
Hopper Assembly			
-Avadex BW leaked from the right hopper. The leak was repaired at	Beginning of Test		
-One hopper cover latch was lost at	20	273	(675)
Rotor Drive			
-The rotor drive chains broke three times	During the Test		

DISCUSSION OF MECHANICAL PROBLEMS

Drive Chains: The chains (FIGURE 6) connecting the hopper rotor drives failed due to overloading at start up when Avadex BW had compacted in the bottom of the hopper. Chain failure was minimized by rocking the rotors back and forth with a wrench to loosen them before starting the hydraulic motors. It is recommended that the drive be modified to reduce drive chain failure.

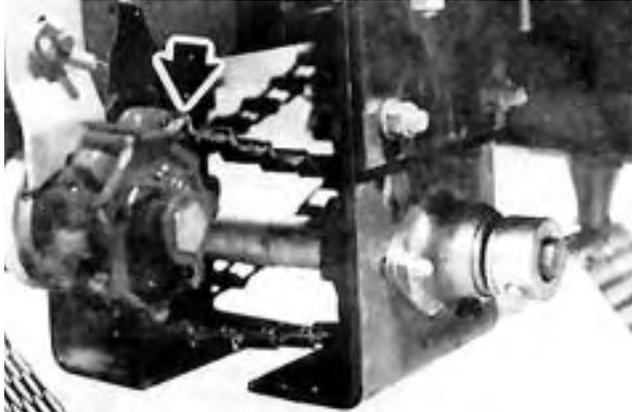

FIGURE 6. Drive Chain.

**APPENDIX I
SPECIFICATIONS**

MAKE: Gandy Granular Applicator
MODEL: 448-8SNF
SERIAL NUMBER: left end hopper 707079
left centre hopper 707078
right centre hopper 707234
right end hopper 707233

OVERALL DIMENSIONS:

	<u>Field Position</u>	<u>Transport Position</u>
-- height	1345 mm (4.4 ft)	1345 mm (4.4 ft)
-- length	4990 mm (16.4 ft)	11540 mm (37.9 ft)
-- width	15940 mm (52.3 ft)	2670 mm (8.8 ft)

METERING SYSTEM:

- type: variable orifice fed by "flo control" rotor chain from hydraulic motors
- drive (rotor): chain from hydraulic motors
- adjustment: orifice size
- transfer to ground: free fall from orifice onto expanded metal deflector
- number of discharge orifices: 96
- orifice spacing: 152 mm (6 in)
- discharge height: 570 mm (22 in)
- effective spreading width: 14630 mm (48.0 ft)

WEIGHTS: (Unloaded in field position)

- left outer wheels: 291 kg (640 lb)
- left inner wheel: 323 kg (710 lb)
- right inner wheel: 314 kg (690 lb)
- right outer wheels: 286 kg (630 lb)
- hitch: 114 kg (250 lb)
- Total: 1328 kg (2920 lb)

WHEELS:

- number: 6, tire size 6.70 x 15, 4-ply, rib implement

HOPPER CAPACITY: 0.65 m³ (23 ft³)

NUMBER OF LUBRICATION POINTS:

- grease: 12
- oil: 20

**APPENDIX II
MACHINE RATINGS**

The following rating scale is used in PAMI Evaluation Reports:

- | | |
|---------------|--------------------|
| (a) excellent | (d) fair |
| (b) very good | (e) poor |
| (c) good | (f) unsatisfactory |

**APPENDIX III
METRIC UNITS**

In keeping with the intent of the Canadian metric conversion program, this report has been prepared in SI Units. For comparative purposes, the following conversions may be used:

- | | |
|-------------------------------------|-------------------------------|
| 1 kilometre per hour (km/h) | = 0.62 mile per hour (mph) |
| 1 hectare (ha) | = 2.47 acres (ac) |
| 1 kilogram (kg) | = 2.20 pounds (lb) |
| 1 kilogram per hectare (kg/ha) | = 0.89 pound per acre (lb/ac) |
| 1 kilowatt (kW) | = 1.34 horsepower (hp) |
| 1 metre (m) = 1000 millimetres (mm) | = 39.37 inches (in) |



3000 College Drive South
Lethbridge, Alberta, Canada T1K 1L6
Telephone: (403) 329-1212
FAX: (403) 329-5562
<http://www.agric.gov.ab.ca/navigation/engineering/afmrc/index.html>

Prairie Agricultural Machinery Institute

Head Office: P.O. Box 1900, Humboldt, Saskatchewan, Canada S0K 2A0
Telephone: (306) 682-2555

Test Stations:
P.O. Box 1060
Portage la Prairie, Manitoba, Canada R1N 3C5
Telephone: (204) 239-5445
Fax: (204) 239-7124

P.O. Box 1150
Humboldt, Saskatchewan, Canada S0K 2A0
Telephone: (306) 682-5033
Fax: (306) 682-5080