

Evaluation Report

87



Wilger Model 804S Field Sprayer

A Co-operative Program Between



WILGER MODEL 804S FIELD SPRAYER

MANUFACTURER AND DISTRIBUTOR:

Wilger Industries Ltd.
2409 Thayer Avenue
Saskatoon, Saskatchewan
S7L 5Y1

RETAIL PRICE:

\$3325.00 (February, 1978, f.o.b. Saskatoon, complete with electric boom control, 9.5L x 15 Flotation tires, ball hitch, pump hose quick couplers and Tee Jet 8002 stainless steel nozzles).

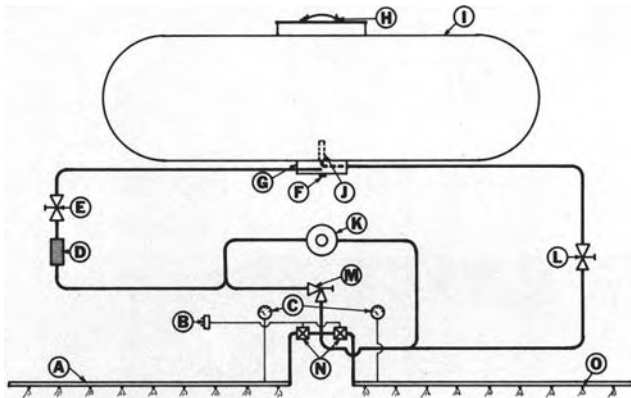

FIGURE 1. Flow Diagram for Wilger Model 804S: (A) Boom, (B) Boom Control Switch, (C) Pressure Gauges, (D) Line Strainer, (E) Shut-off Valve, (F) Drain, (G) Sump, (H) Lid, (I) Tank, (J) Agitator, (K) Pump, (L) Agitator Control, (M) Pressure Regulator, (N) Electric Boom Valves, (O) Nozzle.

SUMMARY AND CONCLUSIONS

Functional performance of the Wilger Model 804S field sprayer was very good.

The Wilger 804S performed satisfactorily at field speeds up to 12 km/h (7.5 mph) resulting in a field capacity of 29 ha/h (72 ac/h). The booms and boom wheel assemblies performed well.

Nozzle distribution patterns were very uniform at pressures greater than 285 kPa (41 psi) with the TeeJet 8002, 80° stainless steel nozzle tips supplied with the sprayer. Nozzle delivery increased 10% after 39 hours of operation. However, test results indicated considerable variability among batches of nozzles, thought to be attributed to quality control problems. A different batch of the same nozzles tested in 1976 had very uniform distribution at pressures above 205 kPa (30 psi) and nozzle delivery increased only 0.6% after 52 hours of operation.

Pump capacity was adequate to agitate and apply most commonly used chemicals. Plumbing system pressure loss was minimal and would not affect sprayer operation or calibration. Strainer and nozzle plugging was infrequent.

Flow to the booms was conveniently controlled with electric switches mounted on the tractor. Nozzle check valves occasionally stuck open allowing some nozzles to drip when boom control valves were closed. The pressure control was difficult to reach and the agitation control could not be reached from the seat of most tractors. Boom height was easily adjusted without the use of tools. Nozzle angle adjustment was inconvenient. Folding into transport, hitching and servicing were all convenient. The operator's manual adequately outlined sprayer operation and calibration charts were provided.

Some minor mechanical problems occurred during the test. The booms could be damaged if specific procedures were not followed when folding into transport. The boom extension hoses were damaged from rubbing against the boom tires and boom frame.

RECOMMENDATIONS

It is recommended that the manufacturer consider:

1. Modifications to prevent the boom extension hoses from

- rubbing on the boom tires and boom frame.
2. Recommending a tire pressure for the inner boom wheels to suit both field and transport operation.
3. Modifications to permit convenient adjustment of boom pressure and tank agitation from the tractor seat.
4. Supplying a high capacity 100 mesh strainer at the tank filler opening.
5. Supplying a metric or dual calibrated pressure gauge or suitable conversion charts to facilitate sprayer operation after conversion to the SI system.
6. Expanding the operator's manual by providing both English and SI units and including more detailed calibration instructions and a parts list.
7. Modifying the tank lid to eliminate loss of filler beads through the vent hole into the tank.
8. Increasing the load capacity of the ball and socket hitch or, alternatively, supplying hitch safety chains as standard equipment.

Chief Engineer: E. O. Nyborg

Senior Engineer: E. H. Wiens

Project Engineer: K. W. Drever

THE MANUFACTURER STATES THAT

With regard to recommendation number:

1. Nylon cord ties are supplied to prevent this problem but apparently were not supplied with the sprayer tested. Modifications on 1978 models will result in shorter boom extension hoses.
2. Tire pressures on boom wheels should be low enough to provide flexing, a soft ride and maximum flotation. The low pressure is adequate for short trips at reasonably slow speeds and is suitable for most farm operations. The 32 psi boom tire pressure is recommended for extended, high speed transport (50 to 60 mph) to prevent tire overheating.
3. Since boom pressure and tank agitation do not normally require frequent adjustment, it is felt the extra fittings and hoses necessary to provide for convenient adjustment are not justified. However, future models will be available with optional electrical remote control for these adjustments.
4. Large, inexpensive, fine nylon mesh filler screens will be provided with 1978 and future models.
5. Metric or dual calibrated gauges along with conversion charts will be provided in the future as need arises.
6. No change in the operator's manual is planned for early 1978 models. However, later models will have a revised and improved manual.
7. This problem was not common to all units. The 1978 models have a new, larger, threaded filler cap made of solid polyethylene.
8. We have had no other reports of ball and socket hitch failure. The next larger size of coupler is considerably more expensive and too large to fit many of the tractors used for spraying.

GENERAL DESCRIPTION

The Wilger model 804S is a trailing, boom type field sprayer. The trailer is mounted on tandem axles, while each boom is supported by two wheels, one near the centre and one near the outer end. The low profile 1818 L (400 gal) galvanized steel tank is equipped with hydraulic agitation and a fluid level indicator.

The Wilger 804S has 48 nozzles spaced at 508 mm (20 in) giving a spraying width of 24.4 m (80 ft). Nozzles are equipped with check valves to prevent spray drip when the boom control valve is closed. Boom height and spray angle are adjustable. The booms fold back for transport. The pressure regulator, pressure gauges and boom control valves are mounted on a stand near the front of the trailer hitch. The 540 rpm teflon roller pump is driven from the tractor power take-off. The test machine was equipped with optional electric boom control valves. Valve switches were mounted on the tractor.

FIGURE 1 presents a flow diagram for the Wilger 804S while detailed specifications are given in APPENDIX 1.

SCOPE OF TEST

The Wilger 804S was operated for 78 hours in the conditions shown in TABLE 1 while spraying about 1802 ha (4453 ac). It was evaluated for quality of work, pump capacity, ease of operation, operator safety and suitability of the operator's manual. The standard Tee Jet 8002 stainless steel nozzle tips were replaced with TeeJet 8001 brass nozzle tips for 39 hours of operation.

TABLE 1. Operating Conditions

Chemical Applied	Hours	Speed		Spraying Rate		Field Area	
		km/h	mph	ha/h	ac/h	ha	ac
2, 4-D	21	10	6.0	24	59	504	1245
2, 4-D, Banvel mixture	13	9	5.5	22	54	286	707
Banvel	16	9	5.5	22	54	352	870
Carbyne	22	10	6.0	24	59	528	1305
Avenge/ Bucitrl M mixture	6	9	5.5	22	54	132	326
TOTAL	78					1802	4453

RESULTS AND DISCUSSION

QUALITY OF WORK

Distribution Patterns: FIGURES 2 and 3 show spray distribution patterns along the boom when equipped with the 80° Tee Jet 8002 stainless steel nozzles which were supplied with the sprayer. The coefficient of variation (CV)¹ at a 140 kPa (20 psi) boom pressure was 39% with application rates along the boom varying from 37 to 121 L/ha (3.3 to 10.8 gal/ac) at 8 km/h (5 mph). High spray concentration occurred below each nozzle with inadequate coverage between nozzles. Although low pressures are not recommended, the distribution pattern at the 140 kPa (20 psi) boom pressure is shown to illustrate the poor patterns typical at low pressure. At 275 kPa (40 psi) (FIGURE 3) the distribution pattern improved considerably, reducing the CV to 10%. Application rates along the boom varied from 80 to 121 L/ha (7.1 to 10.8 gal/ac) at 8 km/h (5 mph). Higher pressure improved distribution by increasing the overlap among nozzles. Higher pressure however, usually causes more spray drift.

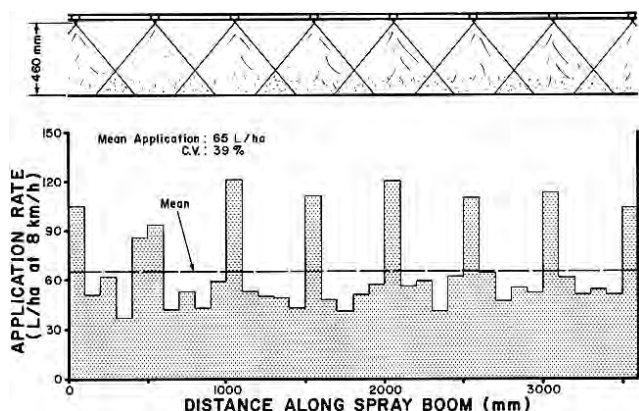

FIGURE 2. Typical Distribution Pattern along the Boom at 140 kPa (20 psi) with TeeJet 8002 (80°) nozzles, at a 460 mm (18 in) Nozzle Height.

FIGURE 4 shows how boom pressure affects spray pattern uniformity for 80°, TeeJet 8002 stainless steel nozzles such as those supplied with the sprayer. Three different batches of nozzles, representing different nozzle manufacturing times are shown. As can be seen, large variations in pattern uniformity can be expected for 80° TeeJet 8002 stainless steel nozzles. This variation appears to be due to quality control procedures used by the nozzle manufacturer who supplies the sprayer manufacturer. For example, one batch of new nozzles produced acceptable distribution patterns at pressures above 185 kPa (27 psi) and very uniform patterns at pressures above 205 kPa (30 psi) while another batch of new nozzles produced acceptable distribution only at pressures above 235 kPa (34 psi) and

¹The coefficient of variation (CV) is the standard deviation of application rates for successive 100 mm (4 in) sections along the boom expressed as a percent of the mean application rate. The lower the CV, the more uniform is the spray coverage. A CV below 10% indicates very uniform coverage while a CV above 15% indicates inadequate uniformity for chemicals having a narrow application range. The CV's above were determined in stationary laboratory tests. In the field, CV's may be up to 10% higher, due to boom vibration and wind. Different chemicals vary as to the acceptable range of application rates. For example, 2, 4-D solutions have a fairly wide acceptable range ($\pm 14\%$) while chemicals such as Bucitrl M have a very narrow range.

very uniform distribution at pressures above 285 kPa (41 psi).

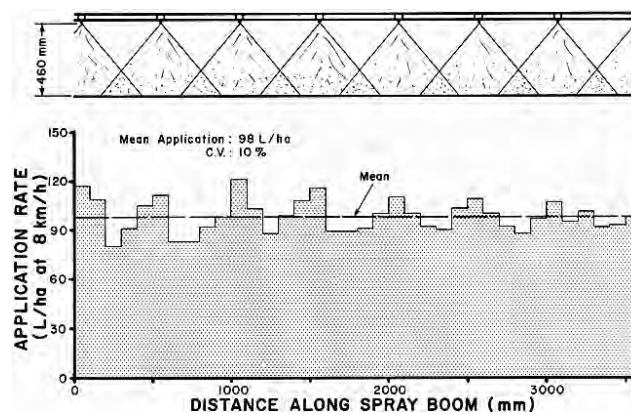

FIGURE 3. Typical Distribution Pattern along the Boom at 275 kPa (40 psi) with Tee Jet 8002 (80°) nozzles, at a 460 mm (18 in) Nozzle Height.

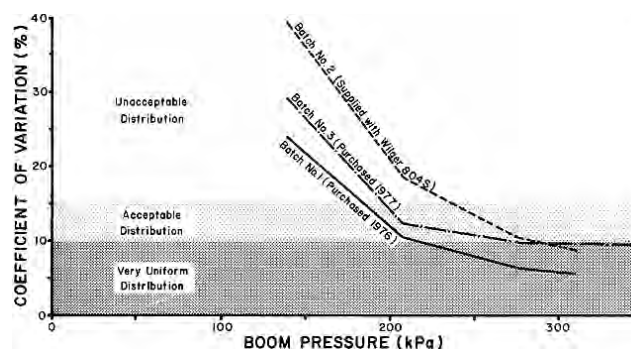

FIGURE 4. Spray Pattern Quality Variation Among Three Different Batches of New Tee Jet 8002 Stainless Steel Nozzles, Operated at a 460 mm (18 in) Nozzle Height.

FIGURE 5 shows the effect of boom pressure on spray pattern uniformity for 65°, Tee Jet 6502 brass nozzles. These nozzles have the same capacity as the 8002 nozzles, which were supplied with the sprayer but have a 65° spray angle rather than an 80° angle. Two batches, representing two different nozzle manufacturing times, are shown. Both batches produced acceptable distributions at pressures above 215 kPa (31 psi) while one batch produced very uniform distribution at pressures above 240 kPa (35 psi) and the other at pressures above 285 kPa (41 psi). Although researchers have reported that 80° nozzles usually produce better spray distribution than 60° nozzles, it can be seen that the variation among different batches produced by the nozzle manufacturer are greater than the variation between Tee Jet 6502 and Tee Jet 8002 nozzles.

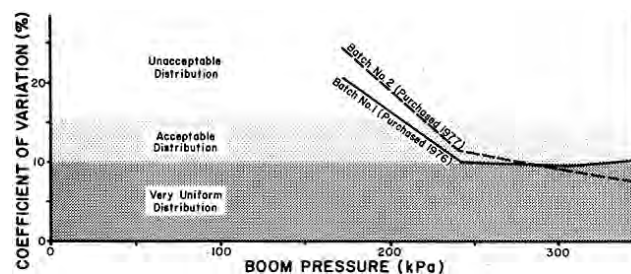

FIGURE 5. Spray Pattern Quality Variation Between Two Different Batches of New Tee Jet 6502 Brass Nozzles, Operated at a 560 mm (22 in) Nozzle Height.

Spray Drift: To obtain acceptable spray distribution, the Wilger 804S had to be operated above 235 kPa (34 psi) with the nozzles that were supplied with the sprayer. As can be seen from FIGURE 4, large variations are possible in new stainless steel nozzles and for some nozzle batches acceptable distribution patterns may be possible with pressures as low as 185 kPa (27 psi).

Work by the Saskatchewan Research Council² indicates that

²Maybank, J.; Yoshida, K.; Shewchuk, S.R. "Comparison of Swath Deposit and Drift Characteristics of Ground-Rig and Aircraft Herbicide Spray Systems" (Report of the 1975 Field Trials), Saskatchewan Research Council Report No. P76-1, January, 1976, p. 16.

³Maybank, J.; Yoshida, K., "Droplet Deposition and Drift from Herbicide Sprays - Analysis of the 1973 Ground-Rig Trials", Saskatchewan Research Council Report No. P73-16, December, 1973, p. 65.

drift at the edge of the spray pattern is usually less than 1% of the amount sprayed when using Tee Jet 8002 nozzles at 205 kPa (30 psi). Drift from sprayers using lower capacity 65° nozzles is about 3% of the amount sprayed at 170 kPa (25 psi) and 6% at 275 kPa (40 psi)³. The nozzles supplied with the Wilger 804S were effective in minimizing drift, since they could be operated at low pressures, resulting in large droplet size and the 80° nozzle angle permitted operating the boom lower to the ground than with 65° nozzles.

Nozzle Calibration: FIGURE 6 shows the delivery of the Tee Jet 8002 stainless steel nozzles which were supplied with the sprayer. Nozzle delivery increased 10% after 39 hours of field use. Some researchers indicate that a nozzle needs replacement once discharge has increased by more than 10%.

FIGURE 6 also shows the variability in delivery rate among individual nozzles. The shaded areas represent the range over which the deliveries from 10 nozzles varied when new and after field tests. A narrow range and low CV indicates that nozzle discharges are very similar while a wider range indicates a higher variability among individual nozzle deliveries. Variability among individual nozzle deliveries on the Wilger 804S was low. The CV of nozzle deliveries was only 1.7% for new nozzles and only 2.3% after 39 hours.

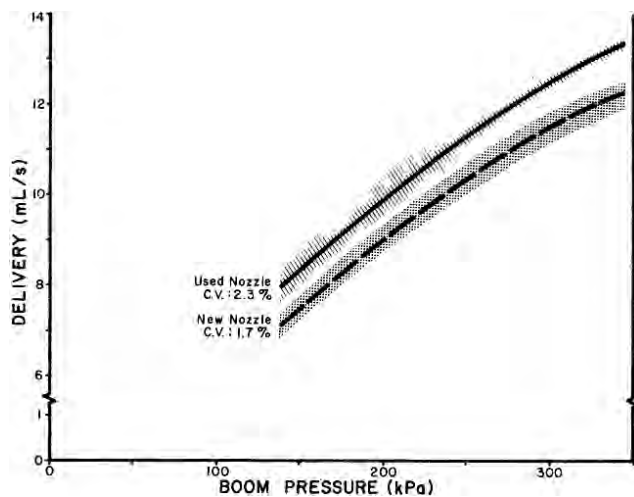

FIGURE 6. Delivery Rates of the Tee Jet 8002 Stainless Steel Nozzles - New and Used 39 Hours.

Delivery from the new nozzles supplied with the Wilger 804S was about 10% lower than the delivery from another batch of new TeeJet 8002 stainless steel nozzles tested in 1976. The nozzle delivery increased only 0.6% after field use in 1976 as opposed to 10% in 1977. It is suspected that the high increase recorded on the TeeJet 8002 stainless steel nozzles in 1977 was due to quality control problems with the nozzle manufacturer. After field use, resulting in a 10% increase, the nozzles finally delivered the manufacturers rated output.

Use of Optional Nozzles: The Wilger 804S was equipped with standard Tee Jet nozzle body assemblies (FIGURE 7) so a wide range of nozzle tips could be used. The nozzle height and angle was adjustable, permitting use of flat fan, flood or cone nozzles.

Booms: The Wilger 804S was driven over a series of standard obstacles⁴ to assess boom stability. FIGURE 8 shows vertical boom bounce when the boom wheels were driven over three different obstacle sizes at 9 km/h (5.6 mph). The maximum boom end movement was a 70 mm (2.8 in) lift and a 80 mm (3.1 in) drop. This resulted in a boom height variation from 380 to 530 mm (15.0 to 20.9 in), compared to the correct 460 mm (18 in) boom height. FIGURE 9 compares nozzle overlap at these three boom heights.

The lift and drop at the centre of the inner boom section was about half that at the boom end. Boom bounce at 6 km/h (3.7 mph) was similar to that at 9 km/h (5.6 mph) while at 12 km/h (7.5 mph) boom bounce was about 1.5 times greater than that at 9 km/h (5.6 mph).

Driving over an obstacle with the boom wheels also caused the forward boom speed to vary in relation to the tractor speed, since the

boom initially deflects rearward and then springs forward. FIGURE 10 shows the forward boom end speed, relative to the ground, when the boom wheels were driven over the standard obstacles. Boom speed determines the application rate. For a fixed boom pressure, high application occurs at low speeds and low application occurs at high speeds. Large variations in application rate can result from horizontal boom movement on rough ground. For example, driving over a 65 mm (2.6 in) obstacle at 9 km/h (5.6 mph) caused boom end speed to vary from 4.7 to 12.5 km/h (2.9 to 7.8 mph). Resulting application rates could vary from 188 to 71 L/ha (16.7 to 6.3 gal/ac). Variation in boom end speed occurred in only six-tenth of a second while the sprayer travelled 1500 mm (59 in). Boom end speed variations were similar at operating speeds of 6 and 9 km/h (3.7 and 5.6 mph). At 12 km/h (7.5 mph) speed variations were about 1.5 times larger.

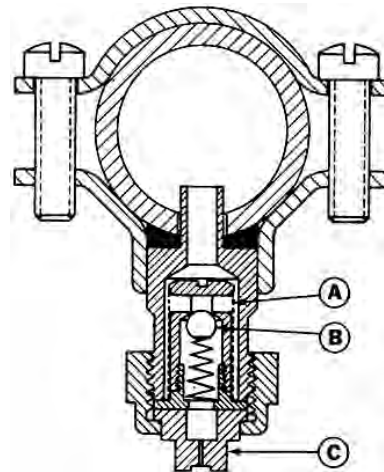

FIGURE 7. Cross Section of Nozzle: (A) Strainer, (B) Check Valve, (C) Nozzle Tip.

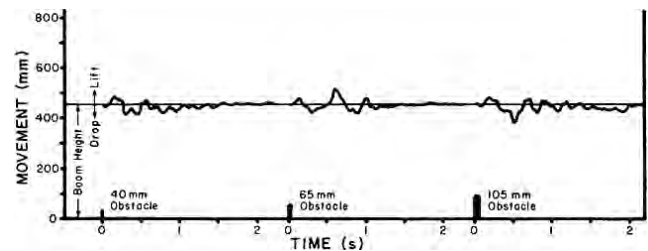

FIGURE 8. Typical Vertical Movement at Boom End lift and drop when the Boom Wheels are Driven over Different Obstacles at a Forward Speed of 9 km/h (5.6 mph).

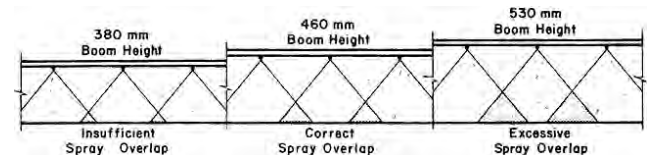

FIGURE 9. The Effect of Boom Lift and Drop on Spray Overlap.

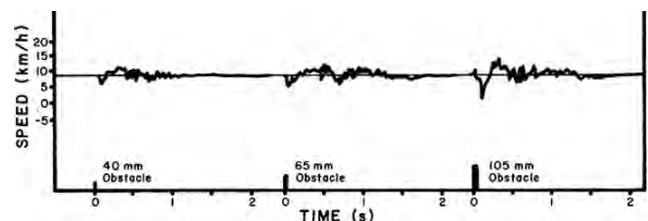

FIGURE 10. Typical Variation in Boom End Speed when the Boom Wheels are Driven over Different Obstacles at an Average Forward Speed of 9 km/h (5.6 mph).

Boom stability measurements and field observations indicated that boom stability on the Wilger 804S was good. This was attributed to the heavy boom rail construction as well as the use of a support wheel near the centre and the end of each boom. Boom operation was satisfactory on rolling terrain and across gullies.

Field Speeds: The Wilger 804S performed satisfactorily at speeds up to 12 km/h (7.5 mph), resulting in a field capacity of 29 ha/h (73 ac/h).

⁴PAMI T764-R78, Detailed Test Procedures for Field Sprayers.

Pressure Losses in Plumbing System: The non-drip nozzle check valve (FIGURE 7) caused a 35 kPa (5 psi) pressure drop at the entrance of each nozzle. This pressure drop could affect calibration and nozzle spray patterns since it was not detected by the sprayer pressure gauges. Control valve pressure must be set about 35 kPa (5 psi) higher than the desired application pressure to compensate for this pressure drop. A pressure loss of up to 70 kPa (10 psi) occurred through the boom valves but this did not affect nozzle calibration since spraying pressure was monitored at the boom ends. Pressure loss along the booms was insignificant.

Pressure Gauges: Each boom was equipped with its own pressure gauge. When new, both gauges were within 7 kPa (1 psi) of the correct reading, over the normal operating range. After field tests, gauges read to within 14 kPa (2 psi) of the correct pressure. The pressure gauges were calibrated only in psi. To facilitate conversion to the metric system, it is recommended that gauges calibrated in both psi and kPa, or suitable conversion tables be supplied.

Tank Strainer: No strainer was provided at the tank filler opening. A 100 mesh, high capacity strainer would be desirable to remove foreign particles before they could enter the sprayer tank.

Line Strainer: The 50 mesh screen located in the line strainer adequately removed most particles that could damage the pump. Water containing fine sand, which could pass through the 50 mesh screen, could cause pump damage. The plastic strainer bowl was easily removed for cleaning. No tools were needed.

Nozzle Strainers: The 50 mesh nozzle strainers effectively prevented nozzle plugging. Check valves located in the nozzle strainers usually stopped boom drip when the boom control valve was closed. Some check valves occasionally stuck open, requiring tapping to seat them.

Soil Compaction and Crop Damage: The trailer and boom wheels travelled over about 2.9% of the total field area sprayed. The wheel tread of the trailer was 1770 mm (5.8 ft), corresponding to the wheel tread on most tractors. The only crop damage, in addition to that caused by the tractor wheels, was that caused by the boom wheels. This was 1.4% of the total area sprayed. The soil contact pressure beneath the boom wheels was less than half that of an unloaded one-half ton truck. The average soil contact pressure under the sprayer wheels with a full tank are given in TABLE 2.

TABLE 2. Soil Compaction by Sprayer Wheels

	Average Soil Contact Pressure*			
	With Tank Full		Tire Track Width	
	kPa	psi	mm	in
Trailer Wheels	179	26	180	7.1
Inner Boom Wheels	83	12	93	3.7
Outer Boom Wheels	90	13	75	3.0

*For comparative purposes, an unloaded one half ton truck has a soil contact pressure of about 200 kPa (30 psi).

PUMP CAPACITY

Agitation Capability: The new pump had a delivery rate of 1.27 L/s (16.7 gal/min) at 275 kPa (40 psi) and 540 rpm (FIGURE 11). This was adequate to apply 148 L/ha (13.2 gal/ac) of emulsifiable concentrates or 65 L/ha (5.8 gal/ac) of wettable powders at 8 km/h (5 mph) and provide sufficient agitation to keep the tank solution properly mixed. Normally recommended agitation rates for emulsifiable concentrates such as 2,4-D are 0.03 L/s per 100 L of tank capacity (1.5 gal/min per 100 gal of tank capacity). For wettable powders such as Atrazine and Sevin, recommended agitation rates are 0.05 L/s per 100 L of tank capacity (3.0 gal/min per 100 gal of tank capacity).

Using a pump wear allowance of 20%, a worn pump could apply 110 L/ha (9.8 gal/ac) of emulsifiable concentrates or 27 L/ha (2.4 gal/ac) of wettable powders with sufficient agitation. The pump was therefore adequate for most chemicals when new but was inadequate for wettable powders when worn.

Operation at Reduced Speed: FIGURE 11 also shows that reducing pump speed from 540 to 400 rpm decreased pump output by 32%. Reduced pump speed would occur when obtaining the correct ground speed to suit nozzle calibration, by reducing the engine speed.

Pump Wear: Pump capacity decreased by 9.3% after 78 hours

of field use. Pump wear depends upon the type of chemical sprayed and abrasive materials in the water.

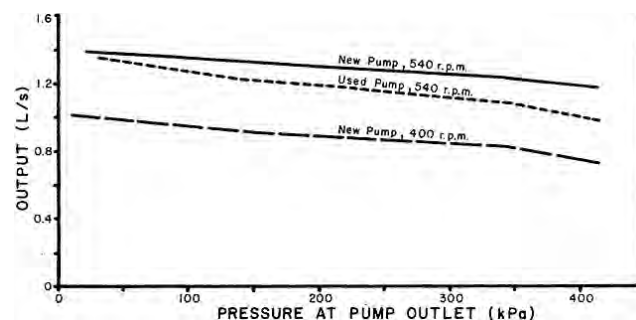

FIGURE 11. Pump Curves.

EASE OF OPERATION

Controls: Application rate was controlled by adjusting ground speed and boom pressure. Pressure could be controlled with either the pressure regulator or the agitator control valve (FIGURE 12). Chemical flow to each boom was easily controlled with the electric solenoid switches mounted on the tractor. The tank shut-off valve was conveniently located at the front of the tank. The pressure gauges were visible from the tractor seat. The pressure regulator was difficult to reach from the tractor seat while the agitator control valve could not be reached. Relocation of these controls so that they could be conveniently adjusted from the tractor seat would be desirable.

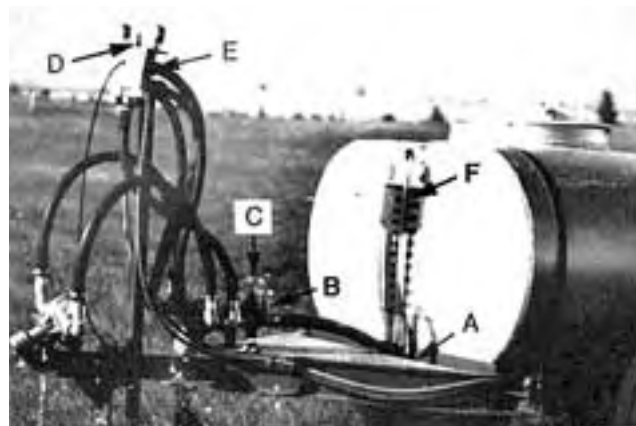

FIGURE 12. Controls: (A) Platform, (B) Agitator Control, (C) Shut-off Valve, (D) Pressure Regulator, (E) Electric Boom Valve, (F) Liquid Level Indicator.

The tank liquid level indicator was easy to read if the solution in the tank was opaque. With clear solution such as Banvel, the fluid level in the tube was difficult to read. The gauge gave only a rough indication of fluid level since operation on hills and movement of liquid in the tank caused the indicator reading to fluctuate.

Transport: The Wilger 804S sprayer could be folded into transport (FIGURE 13) or placed into field position in about five minutes. The boom wheel lock pins were difficult to remove and insert. The operator's manual stated that the booms had to be completely raised before folding the outer booms to transport. This instruction had to be followed or else the boom extension hose caught the transport pin and bent the boom pipe.

The Wilger 804S had a turning radius of only 5.9 m (19.5 ft) in transport, providing good maneuverability. Backing the sprayer in transport position was awkward. The sprayer towed well at speeds up to 40 km/h (25 mph).

The operating instructions suggested that inner boom wheel tire pressures be increased to 220 kPa (32 psi) for high speed transport from the 55 kPa (8 psi) recommended for field use. This was impractical since it was inconvenient to inflate the tires in the field when preparing for transport. It is recommended that the manufacturer suggest an inner boom wheel tire pressure suitable for both field and transport use.

Tank Filling: The low profile tank was easily filled by gravity from a nurse tank on a farm truck. The 255 mm (10.0 in) opening was adequate for adding chemicals and water. The tank filler opening location and the platform at the front of the sprayer (FIGURE 12)

made adding chemical to the tank safe and convenient.



FIGURE 13. Wilger 804S Folded into Transport Position Showing Detail of Boom Wheel Lock Pin.

Nozzle Adjustment: Nozzle height on each of the four boom sections could be adjusted, without tools, by loosening the setscrew and raising or lowering the boom section with the boom adjusting handle. Nozzle angle remained constant at all boom heights. Care had to be exercised when placing the boom into field position, since the operator's fingers could be pinched between the boom adjusting handle and the boom (FIGURE 14).

Nozzle angle adjustment was time consuming, requiring the loosening of 18 U-bolts before the boom could be rotated.



FIGURE 14. Fingers Pinched Between Boom Adjusting Handle and Boom when Placing the Boom in Field Position.

Nozzle Cleaning: The nozzles were easily removed, with a wrench, for cleaning.

Hitching: The empty sprayer could be hitched to a tractor without a hitch jack. A jack was needed when the tank was full. A quick disconnect coupling was used to attach the sprayer pump to the power take-off shaft. The power leads for the solenoid boom valves were connected to the tractor battery with alligator clips.

Servicing and Cleaning: Lubrication was convenient since all eight fittings were accessible. The tank could be completely drained through the drain plug located in the tank sump. The tank lid (FIGURE 15) was in two sections. Removal of the second section created a 560 mm (22 in) diameter hole, allowing easy tank access for cleaning. A safety decal advising not to enter the tank unless it was properly flushed and vented was located near the tank filler opening.

OPERATOR SAFETY

Slow Moving Vehicle Sign: The sprayer was equipped with a slow moving vehicle sign to comply with safety regulations.

Hitch: The optional ball and socket hitch on the Wilger 804S was rated for trailers with a gross weight less than 190 kg (300 lb). With a full sprayer tank, the hitch was overloaded by 75%. It is recommended that the manufacturer consider supplying a heavier hitch coupling or equipping the sprayer with hitch safety chains.

Caution: Operators of all spraying equipment are cautioned to wear suitable eye protection, respirators and clothing to minimize operator contact with chemicals. Although many commonly used agricultural chemicals appear to be relatively harmless to humans, they may be deadly. In addition, little is known about the long term

effects of human exposure to many commonly used chemicals. In some cases the effects may be cumulative, causing harm after continued exposure over a number of years.

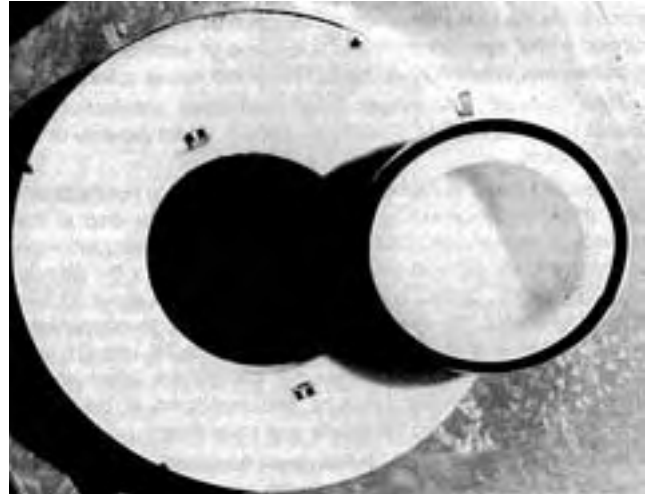

FIGURE 15. Two-Section Tank Lid.

OPERATOR'S MANUAL

The operator's manual outlined pre-operation preparation, general operating instructions and safety tips. Application rates for commonly used nozzles were included but there were no detailed calibration procedures. Connecting and operating instructions, and a parts list for the optional solenoid boom valves were included but no sprayer parts list was provided. It is recommended that calibration procedures and a parts list be included in the operator's manual.

The calibration charts supplied with the sprayer were prepared only in English units. To accommodate the present changeover to the SI (metric) system, calibration charts should be supplied in both English and SI units.

MECHANICAL PROBLEMS

TABLE 3 outlines the mechanical history of the Wilger 804S during 78 hours of field operation while spraying about 1802 ha (4453 ac). Since the intent of the test was evaluation of functional performance, the following failures represent only those, which occurred during the functional testing. An extended durability evaluation was not conducted.

TABLE 3. Mechanical History

Item	Hours	Field Area	
		ha	(ac)
Plumbing Assembly			
-The left boom extension hose began leaking and was replaced at	50	1155	(2854)
-Tank lid filler beads fell into the tank		throughout the test	
Main Frame			
-The ball hitch coupler attaching bolts loosened and were tightened at	66, 72	1525, 1663	3768, 4109
-The hitch coupler was reinforced to eliminate bolt loosening at	72	1663	4109

DISCUSSION OF MECHANICAL PROBLEMS

PLUMBING ASSEMBLY

Boom Extension Hoses: The boom extension hoses rubbed on both the sprayer boom frame and on the boom tires (FIGURE 16), causing hose wear and leakage. It is recommended that hoses be properly secured to eliminate this problem.

Tank Lid: The tank lid was filled with small plastic beads. During field operation, beads fell through the vent hole into the tank. The beads did not create any serious problems but periodic removal from the line strainer was necessary. It is recommended that the manufacturer consider modifying the tank lid to prevent loss of filler beads.

MAIN FRAME

Hitch Coupler: The bolts holding the ball hitch coupler loosened twice due to field vibration, resulting in main frame wear at the bolt holes. No further loosening occurred after the frame was reinforced and the bolts replaced.



FIGURE 16. Boom Extension Hose Wear Due to Rubbing on Frame and Tires.

APPENDIX I SPECIFICATIONS

MAKE:	Wilger Field Sprayer	
MODEL:	804S	
SERIAL NUMBER:	57738	
	Field Position	Transport Position
OVERALL WIDTH:	24,000mm (78.7 ft)	2770mm (9.1 ft)
OVERALL LENGTH:	3580 mm (11.7 ft)	10,210 mm (33.5 ft)
OVERALL HEIGHT:	1570 mm (5.2 ft)	1570 mm (5.2 ft)
	Trailer	Boom
WHEEL BASE:	920 mm (3.0 ft)	
WHEEL TREAD:	1770 mm (5.8 ft)	12,700 mm (41.7 ft)
		20,530 mm (67.4 ft)
TIRE SIZE:	4 - 9.5L x 15, 4 - 400 x 12, 6-ply, rib implement 4-ply, rib implement	
WEIGHTS: (Field Position)	Tank Empty	Tank Full
-- left trailer wheels	277 kg (610 lb)	1120 kg (2470 lb)
-- right trailer wheels	290 kg (640 lb)	1139 kg (2510 lb)
-- inner boom wheels		
-left	109 kg (240 lb)	109 kg (240 lb)
-right	118 kg (260 lb)	118 kg (260 lb)
-- outer boom wheels		
-left	68 kg (150 lb)	68 kg (150 lb)
-right	64 kg (140 lb)	64 kg (140 lb)
-- hitch	20 kg (44 lb)	181 kg (400 lb)
TOTAL	946 kg (2084 lb)	2799 kg (6170 lb)
TANK:	material - galvanized steel capacity - 1818 L (400 gal) line strainer - 50 mesh nozzle strainer - 50 mesh with check valves	
FILTERS:	Hypro C1700 teflon roller hydraulic	
PUMP: (540 rpm PTO driven)	Misaimers (0 to 160 psi)	
AGITATION:	Spraying Systems Model 14810-1, 12 Volt DC, 30 Watt, 3/4 NPT	
PRESSURE GAUGES:	1 inch aluminum pipe	
BOOM SOLENOID VALVES:		
BOOMS:		
NOZZLES: (Tee Jet 8002 stainless steel)	number - 48	
	spacing - 508 mm (20 in)	
SPRAYING WIDTH:	24,384 mm (80.0 ft)	
BOOM ADJUSTMENT:	height - maximum 800 mm (31.5 in) - minimum 260 mm (10.2 in) nozzle angle - 360°	
HITCH HEIGHT ADJUSTMENT:	maximum 406 mm (16 in) minimum 305 mm (12 in)	
LUBRICATION POINTS:		
-- walking beam pivots	2	
-- boom pivots	6	

APPENDIX II MACHINE RATINGS

The following rating scale is used in PAMI Evaluation Reports:

- | | |
|---------------|--------------------|
| (a) excellent | (d) fair |
| (b) very good | (e) poor |
| (c) good | (f) unsatisfactory |

APPENDIX III METRIC UNITS

In keeping with the intent of the Canadian metric conversion program, this report has been prepared in SI units. For comparative purposes, the following conversions may be used:

1 kilometre per hour (km/h)	= 0.62 mile per hour (mph)
1 hectare (ha)	= 2.47 acre (ac)
1 litre per hectare (L/ha)	= 0.09 Imperial gallon per acre (gal/ac)
1 kilopascal (kPa)	= 0.15 pound per square inch (psi)
1 kilowatt (kW)	= 1.34 horsepower (hp)
1 litre per second	= 13.20 imperial gallons per minute (gal/min)
1 metre (m) = 1000 millimetres (mm) (L/s)	= 39.37 inches (in)
1 litre (L)	= 0.22 imperial gallon (gal)



**ALBERTA
FARM
MACHINERY
RESEARCH
CENTRE**

3000 College Drive South
Lethbridge, Alberta, Canada T1K 1L6
Telephone: (403) 329-1212
FAX: (403) 329-5562
<http://www.agric.gov.ab.ca/navigation/engineering/afmrc/index.html>

Prairie Agricultural Machinery Institute

Head Office: P.O. Box 1900, Humboldt, Saskatchewan, Canada S0K 2A0
Telephone: (306) 682-2555

Test Stations:
P.O. Box 1060
Portage la Prairie, Manitoba, Canada R1N 3C5
Telephone: (204) 239-5445
Fax: (204) 239-7124

P.O. Box 1150
Humboldt, Saskatchewan, Canada S0K 2A0
Telephone: (306) 682-5033
Fax: (306) 682-5080