

# Evaluation Report

# 598

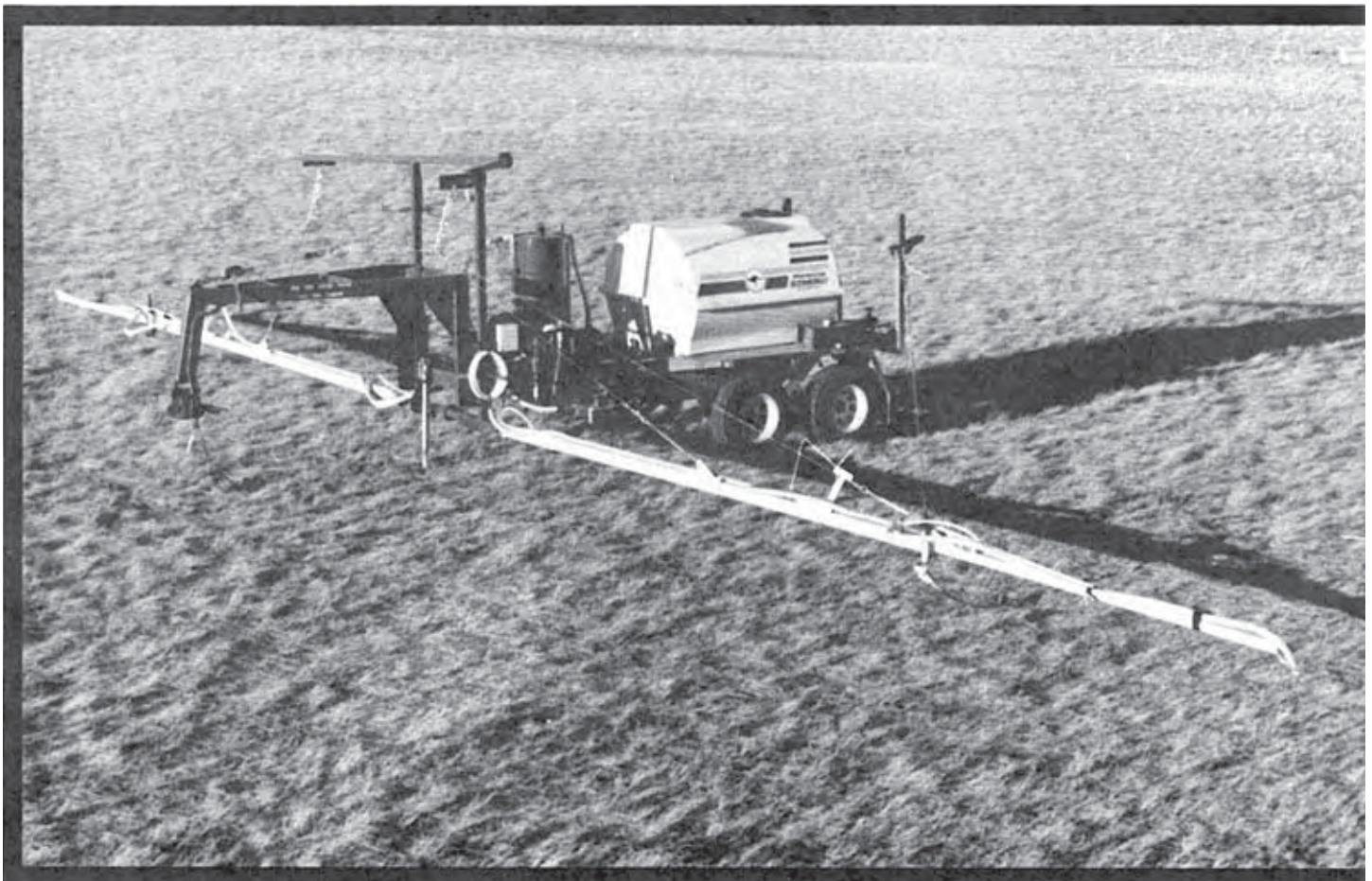

## Spraymaster Model GN 40-60 Field Sprayer

A Co-operative Program Between



# SPRAYMASTER MODEL GN 40-60 FIELD SPRAYER

## MANUFACTURER AND DISTRIBUTOR:

Spraymaster Canada Inc.  
P.O. Box 100  
Spirit River, Alberta  
T0H 3G0  
PH: (403) 864-3735

## RETAIL PRICE:

\$19,700.00 (Nov. 1989, f.o.b. Lethbridge, Alberta).

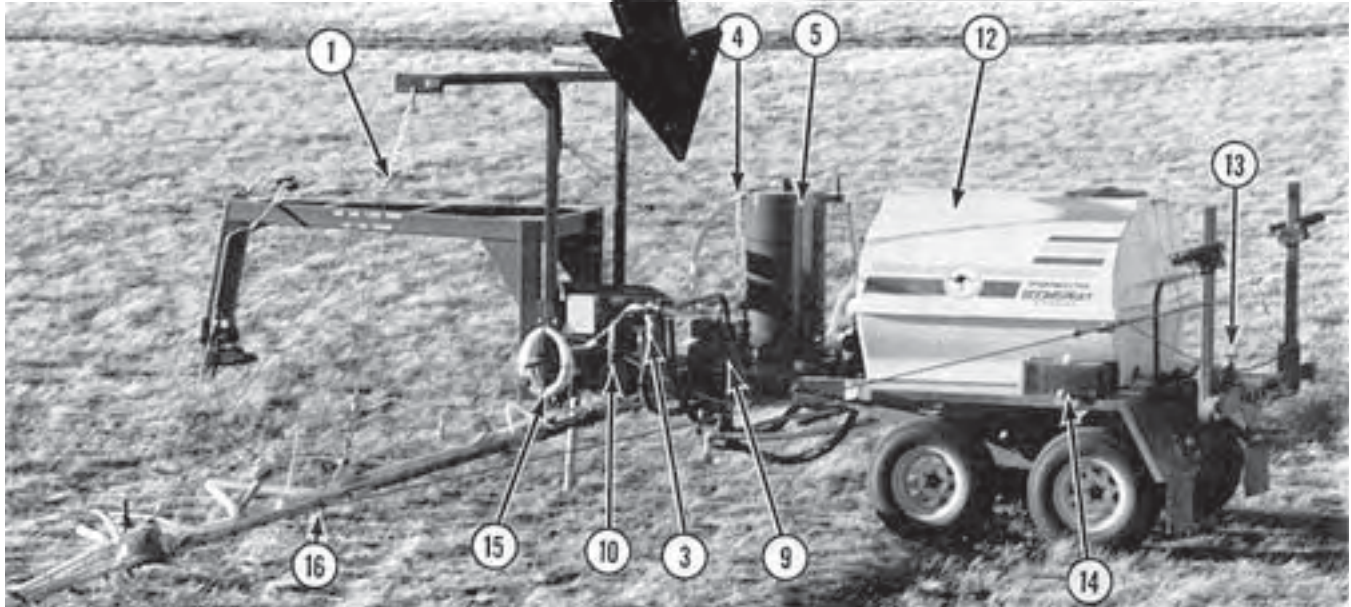
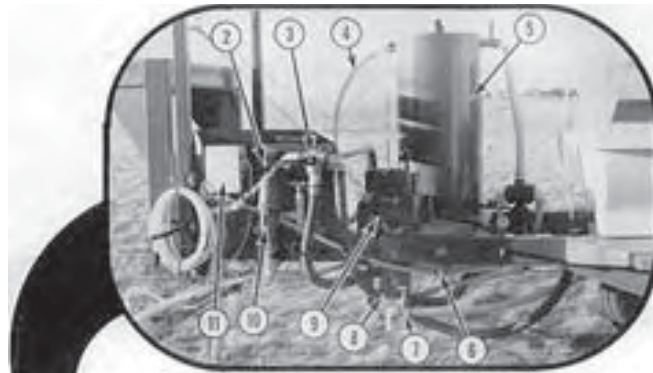

**FIGURE 1.** Spraymaster Model GN 40-60 Field Sprayer: (1) Boom Suspension Cables, (2) Flow and Pressure Sensors, (3) Main Valve, (4) Chemical Inductor Wand, (5) Foam Tank, (6) Agitator Valve, (7) Drain Valve, (8) Pump, (9) Motor and Compressor, (10) Self-Cleaning Line Strainer, (11) Motorized Control and Solenoid Valves, (12) Spray Tank, (13) Reload Hose, (14) Fresh Water Container, (15) Air Hose, (16) Spray Boom and Nozzle Body Assemblies.

## SUMMARY AND CONCLUSIONS

### RATE OF WORK

Operating at speeds between 12 and 22 mph (20 and 35 km/h) resulted in instantaneous work rates between 94 and 168 ac/h (38 and 68 ha/h). At an application rate of 5 gal/ac (56 L/ha), about 96 ac (39 ha) could be sprayed with a full tank.

### QUALITY OF WORK

Application rate accuracy was very good using the application rate controller system. The controller system's flow and speed sensors were both accurate. The application rate controller kept the desired application rate constant over a wide forward speed range. Nozzle pressure varied with forward speed. Nozzle pressures above 15 psi (100 kPa) were used to ensure uniform nozzle spray distribution patterns.

Nozzle distribution patterns were fair using the 110 degree Albus ceramic nozzle tips at a 15.7 in (400 mm) nozzle height and spacing. The spray distribution pattern coefficient of variation (CV) varied from 12.3 to 20.2% for the Albus yellow, orange and red nozzle tips. The nozzles only produced acceptable distribution patterns above 55 psi (379 kPa).

Nozzle delivery was very good using the Albus yellow and red nozzle tips. The delivery rates of the new yellow and red Albus nozzle tips were within about 2% of the manufacturer's delivery specifications. Delivery of the Albus orange nozzles was about 4.6% high.

Nozzle wear was minimal and rated as excellent. Delivery of the used Albus red nozzle tips did not increase after 110 hours of use. Variability among individual nozzle deliveries was very good. The CV was about 1.5 %.

No tests were conducted to evaluate spray drift.

Weed control was good. Weed control was reduced in and

around the sprayer trailer wheels due to dust. Weed control was also reduced at the boom spring skid and end.

System pressure losses were excessive and rated as fair. Nozzle pressures at the left boom were higher than at the right boom. The pressure indicator on the remote control console did not indicate actual nozzle tip pressure. Knowing actual nozzle pressure is important to ensure proper spray droplet deposition.

The strainers were effective and rated as good. The strainers adequately prevented nozzle plugging. The self-cleaning line strainer was desirable, but frequently plugged the front agitator. Boom stability was good. The boom spring skid and cable suspension system reduced vertical boom movement.

The trailer wheel soil contact pressure was about 38 psi (262 kPa). The trailer wheel contact pressure was slightly higher than the unloaded three-quarter ton truck used. Most crop damage resulted from the load placed on the truck rear wheels.

### EASE OF OPERATION AND ADJUSTMENT

Ease of adjusting application rate was good. The desired application rate was programmed into the application rate controller console. Changing application rate more than 20% required different sized nozzle tips. Changing nozzle tips was time consuming.

Ease of operating the controls was good. The Computronics International remote control and automatic rate controller consoles made it easy to control and monitor pressure, speed and application rate from the truck seat. Measurement of the sprayer wheel circumference was needed for the rate controller to function accurately. The agitator valve and motor throttle were adjusted before spraying.

Sprayer maneuverability was very good in both transport and field position. Turning radius was 32 ft (9.8 m).

Ease of boom positioning was good. The booms were manually placed into field and transport position in about three minutes. Care was exercised to prevent getting tangled in the boom ropes and that one boom was always secured on the boom support pad before handling the other boom.

Ease of adjusting nozzles was poor. Nozzle angle was not adjustable. Adjusting nozzle height was difficult and time consuming because the adjustment assembly would bind and the boom suspension cables needed adjustment for proper boom tension and position. Nozzle height was adjusted from about 15 to 22 in (381 to 559 mm). Changing and aligning nozzle tips was also time consuming.

Ease of filling the spray tank was good utilizing the reload hose. A transfer pump was needed and took about 20 minutes to fill the 483 gal (2196 L) spray tank.

Ease of adding chemical to the spray tank was good. The chemical inducting wand was easy to use and took about 20 to 50 seconds to induct 2.2 gal (10 L) of chemical, depending on chemical viscosity and volume of fluid in the spray tank. The spray tank reload, chemical inductor and main control valves were located far apart, making reloading water and inducting chemical at the same time inconvenient.

Ease of hitching was very good. The hitch jack provided was safe and the hitch adjustable for levelling the sprayer trailer.

Ease of cleaning was very good. The Spraymaster was equipped with a self-cleaning line strainer and compressed air system to clean plugged nozzles and strainers.

Ease of draining was very good. The spray tank drain valve and boom hose cock valves were easily accessible.

Ease of lubrication was very good. The five pressure grease fittings were accessible. Lubrication frequency was not indicated.

#### **PUMP PERFORMANCE**

Pump output was very good for application rates below 3.5 gal/ac (40 L/ha). Varying pump speed reduced the pumps performance at high application rates. Agitator output was very good and met recommended agitation rates.

#### **MOTOR PERFORMANCE**

The Kawasaki motor performance was fair. The motor was difficult to start and stalled during field spraying. Average fuel consumption was 0.37 gal/h (1.69 L/h). Servicing the motor was good. The oil dip stick, gasoline cap and air filter were easily accessible. Changing motor oil was messy.

#### **MARKER PERFORMANCE**

Foam mark visibility was very good and foam durability was fair. Some foam marks lasted one hour, but normally lasted about 30 minutes. In hot and breezy weather conditions foam marks lasted less than 10 minutes.

About 200 ac (81 ha) was sprayed with a full foam tank. Operating cost of the foam concentrate was about 10 cents/ac (25 cents/ha). Ease of filling the foam tank was fair. Excessive foaming occurred through the filler opening that spilled on the sprayer and operator, leaving unsightly stains. Operating the foam controls was good. Foam to the booms was controlled by closing the foam tank valve. This was inconvenient and wasted foam. Foam mark placement accuracy was very good in calm weather conditions.

#### **OPERATOR SAFETY**

The operator's manual emphasized operator safety. The pump drive assembly was shielded. Accessories like the chemical inductor wand, fresh water container and compressed air system reduced operator exposure to chemical.

Adjusting the fifth wheel hitch when levelling the trailer required care. A front end loader was used to support the fifth wheel.

#### **OPERATOR'S MANUAL**

The operator's manual was good. The information and illustrations on safety, sprayer operation, sprayer components, maintenance, adjustments, troubleshooting and parts were good.

#### **MECHANICAL HISTORY**

A few mechanical problems occurred during testing. The self-cleaning line strainer valve and motor start cord failed and the lock collars on the boom spring skids loosened several times.

#### **RECOMMENDATIONS**

It is recommended that the manufacturer consider:

1. Modifying nozzle spacing and height to produce acceptable spray distribution patterns at pressures between 15 and 44 psi (100 to 300 kPa).
2. Indicating actual nozzle pressure at the remote console pressure indicator.
3. Modifications to prevent the front agitator from plugging.
4. Modifications to make it easier to adjust nozzle height.
5. Modifying the foam marker system to improve operator convenience when filling with water and foam concentrate.
6. Modifying the line strainer plumbing components to prevent leaking and valve failure.
7. Modifying the chemical inductor for easier handling and better durability.
8. Modifying the boom skid assembly to prevent the lock collars from loosening.
9. Modifying the motor to prevent stalling and to improve starting.

*Manager: R.P. Atkins*

*Technologist: L.B. Storzynsky*

#### **THE MANUFACTURER STATES THAT**

With regard to recommendation number:

1. We recommend that the sprayer boom be operated at a 12 - 14 in height above the target. The manufacturer of the nozzle recommends that Albus nozzles be operated at pressures between 20 and 60 PSI to ensure accurate spray patterns and accurate double overlap at the target area. In addition the ball check valves in the nozzle body assemblies have been replaced with diaphragm units to reduce the pressure at the nozzle.
2. Current models have three equal divisions from the boom solenoids which results in even boom pressure and greater flow rates up to 10 gallons per acre. For rates above this the raven automatic control system is available.
3. The plugged agitator return from the self flushing filter has a range of orifices sizes and should have the largest orifice fitted to prevent this plugging from filter debris.
4. Better fabrication techniques have improved the ease of adjusting boom height. Boom will be adjustable from 10 to 42 in. Lower boom heights will improve the potential for spraying in windy conditions.
5. A three way valve connected to the foam marker tank from the tank filler line has been added to aid in filling the foam tank.
6. All future models will use better sealants and have better quality control during assembly to prevent valve failure.
7. The chemical inductor will have a different mounting-position that will make it easier to use.
8. The lock collars now have a safety lock pin and an improved locking collar.
9. Motors have been changed to Honda and upgraded in power. The stalling, on the Kawasaki's is usually caused when cornering, the oil trip switch turns the engine off due to oil surge in the sump.

#### **Additional Comments:**

The recommended pickup is a short wheelbase 4 x 4 fitted with the same size tires as the sprayer. This will lower ground pressure at the rear wheels of the pickup and provide even ground pressure over all eight tires. A rear mount centre boom section is available as an option to help prevent dust occlusion. Current models are now fitted with self aligning nozzle bodies and diaphragms which facilitate easy jet changing and cures the uneven boom distribution. A nurse truck with an auxiliary pump is recommended to reduce filling time and improve work rates.

## GENERAL DESCRIPTION

The Spraymaster Model GN 40-60 is a trailing, boom-type field sprayer with a fifth wheel trailer hitch. The trailer is mounted on a tandem walking beam axle. Each boom is supported by 2 guy wires, a rope and a leaf spring near the end of the boom. The booms are mounted in front of the trailer and manually fold back for transport. The 483 gal (2196 L) fiberglass tank is equipped with hydraulic agitation, fluid level indicator, filler opening with strainer, reload and drain hose.

The Spraymaster Model GN 40-60 has 48 hose shank nozzle body assemblies with ball check valves spaced at 15.7 in (400 mm), giving a spraying width of 63 ft (19.2 m). Nozzle height is manually adjusted and nozzle angle is zero. A 5.2 hp (3.9 kW) gasoline motor mounted in front of the spray tank drives the centrifugal pump and compressor by belts. The centrifugal pump operates between 3900 and 4400 rpm. The compressor supplies air for the foam marker and cleaning nozzles.

The Spraymaster is equipped with a Computronics International application rate controller and remote control console that mounts inside the truck cab. The remote console contains a pressure indicator and control switches to operate the boom solenoid valves. The application rate controller automatically adjusts the flow control valve to keep the application rate constant when changes to forward speed occur. The sprayer is also equipped with a chemical inductor wand, filler opening access platform, fresh water tank and self-cleaning line strainer.

FIGURE 1 shows the location of the sprayer's major components while detailed specifications are given in APPENDIX 1.

## SCOPE OF TEST

The Spraymaster operated for 73 hours in the conditions shown in TABLE 1 and 2 while spraying about 4167 ac (1687 ha). The AFMRC evaluated for rate of work, quality of work, ease of operation and adjustment, pump, motor and marker performance, operator safety and suitability of the operator's manual.

The Spraymaster sprayer used flat fan 110 degree ceramic nozzle tips. The size of the Albus nozzle tips were distinguished by color. Laboratory tests were performed on Albus yellow, orange and red nozzle tips. During field testing, the red and yellow nozzle tips were used for 70 and 3 hours, respectively. The red Albus nozzle tips were tested an additional 40 hours on a test boom to measure wear.

Table 1. Operating Conditions

Chemical Applied	Field	Hours	Speed		Field Area	
			mph	km/h	ac	ha
2,4-D	Summerfallow	16	15-22	25-35	949	384
2,4-D/Amtrol T	Summerfallow	13	18-21	30-33	597	242
2,4-D/Triton/Roundup	Summerfallow	13	15	25	749	303
2,4-D/Banvel	Wheat	9	16-21	27-34	480	194
Tordon	Wheat	11	17-21	28-34	672	272
Buctril M	Barley	11	15-21	24-34	720	291
Total		73			4167	1687

Table 2. Field Conditions

Topography	Hours	Field Area	
		ac	ha
Level	4	250	101
Undulating	37	2054	832
Rolling	25	1483	600
Hilly	7	380	154
Total	73	4167	1687

## RESULTS AND DISCUSSION

### RATE OF WORK

During field testing, the Spraymaster operated between 12 and 22 mph (20 and 35 km/h) resulting in instantaneous workrates between 94 and 168 ac/h (38 and 68 ha/h), respectively. Actual workrates were less and depended on operator skill and reloading time. With a full spray tank, about 96 ac (39 ha) could be sprayed at 5 gal/ac (56.1 L/ha) before refilling.

### QUALITY OF WORK

**Application Rate:** Application rate accuracy was very good. Application rate accuracy depended on the flow and speed sensor

accuracy. The flow sensor was accurate using the low volume yellow nozzles and indicated about 2% high using the higher volume red nozzle tips. This was considered negligible.

The speed sensor was accurate, but depended on the sprayer wheel circumference. The sprayer wheel circumference varied, depending on field conditions and spray tank fluid volume. As a result, the application rate varied about 4% from a full to near empty spray tank. For greater accuracy, the speed sensor was calibrated in actual field conditions, with the spray tank half full of fluid and sprayer tires properly inflated.

The Spraymaster was equipped with an application rate controller system that automatically controlled the desired application rate when changes in forward speed occurred. FIGURE 2 shows desired application rates of 2.2 and 3.3 gal/ac (25 and 36.5 L/ha) held constant over a wide range of forward speeds. The Spraymaster operated at speeds up to 25 mph (40 km/h) at low application rates. For higher application rates the forward speed was reduced because the application rate decreased at the higher forward speeds (FIGURE 2). For example, at 4.5 and 5.3 gal/ac (50 and 60 L/ha) the application rates started decreasing at forward speeds above 18.6 and 15.5 mph (30 and 25 km/h), respectively.

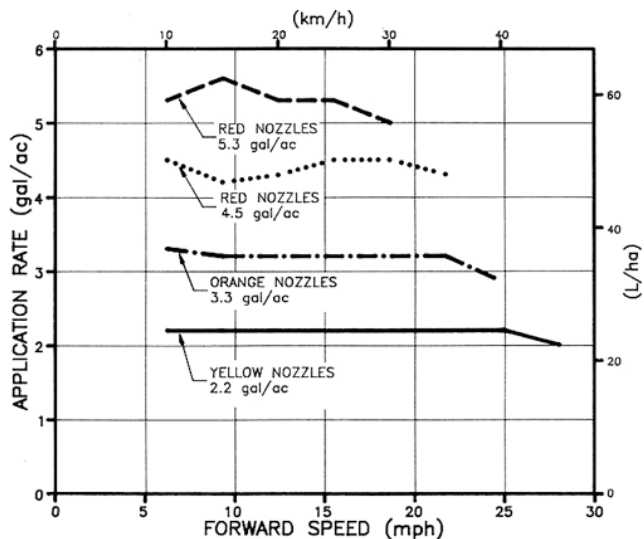

FIGURE 2. Application Rates at Various Forward Speeds Using Albus Nozzles.

Changing forward speed also changed nozzle pressure. FIGURE 3 shows resulting nozzle pressures at various forward speeds using different sized nozzles and application rates. Nozzle pressure increased as forward speed increased. Forward speed used depended on field conditions, workrate required and desired nozzle pressure for proper spray droplet size and distribution patterns. To ensure proper spray deposition characteristics, forward speed should be adjusted to operate at nozzle pressures between 15 and 44 psi (100 and 300 kPa). Unacceptable spray distribution patterns occurred at nozzle pressures below 15 psi (100 kPa). FIGURE 4 shows a typical, spray distribution pattern along the boom using Albus yellow nozzle tips at pressures of 15 psi (100 kPa). The coefficient of variation (CV)<sup>1</sup> was 20%, with application rates along the boom varying from 1.2 to 3.4 gal/ac (13 to 38 L/ha). Operating at nozzle pressures above 43.5 psi (300 kPa) could result in excessive spray drift and evaporation due to smaller droplet sizes.

**Nozzle Calibration:** Nozzle calibration was very good using Albus yellow and red nozzle tips and good using the orange nozzle tips. FIGURE 5 shows the average delivery of Albus red, orange and yellow flat fan ceramic nozzle tips over a range of nozzle pressures. Measured delivery of the new red and orange nozzle tips was about 2.2 and 4.6% higher, respectively than specified by the manufacturer. Measured delivery of the new yellow nozzles was

<sup>1</sup>The coefficient of variation (CV) is the standard deviation of application rates for successive 0.63 in (16 mm) sections along the boom expressed as a percent of the mean application rate. The lower the CV, the more uniform is the spray coverage. A CV below 10% indicates very uniform coverage, while a CV above 15% indicates inadequate uniformity. The CV's above were determined in stationary laboratory tests. In the field, CV's may differ due to boom vibration and wind. Different chemicals vary as to the acceptable range of application rates. For example, 2,4-D solutions have a fairly wide acceptable range while other chemicals may have a narrow range.

1.7% lower than specified by the manufacturer.

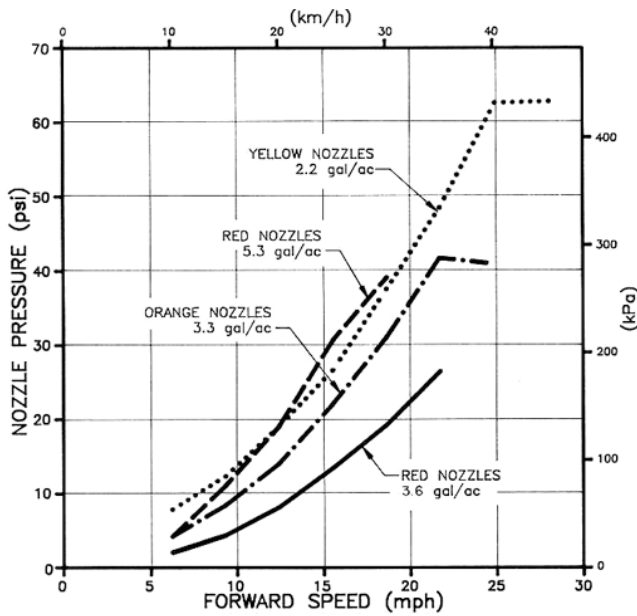

FIGURE 3. Nozzle Pressure At Various Forward Speeds Using Yellow, Orange and Red Nozzle Tips.

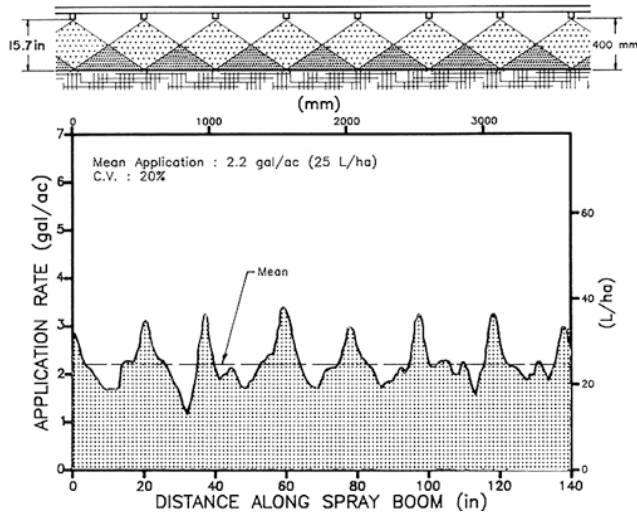

FIGURE 4. Typical Distribution Pattern Along the Boom at a 15 psi (100 kPa) Nozzle Pressure Using Albus Yellow Flat Fan Ceramic Nozzles at a 15.7 in (400 mm) Nozzle Height.

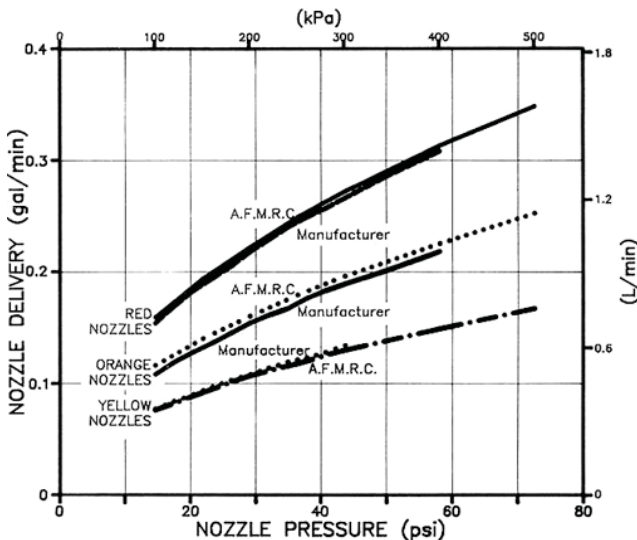

FIGURE 5. Delivery Rates for Albus Yellow, Orange and Red Ceramic Nozzle Tips.

Nozzle wear was minimal and rated as excellent. The delivery

rate of the used red nozzle tips didn't increase after 110 hours of use, indicating no signs of wear. Factors that affect nozzle wear are the type of chemicals sprayed and water cleanliness.

Nozzle variability was very good. The coefficient of variation (CV) is the standard deviation of delivery rates for ten nozzles expressed as a percent of the mean delivery rate. Variability among individual nozzle deliveries for the yellow, orange and red nozzle tips was low. A low coefficient of variation indicates similar discharge rates for all nozzles while a high CV indicates, larger variability among individual nozzle deliveries. The CV of nozzle deliveries was about 1.5% for Albus yellow, orange and red nozzle tips.

**Distribution Patterns:** Nozzle spray distribution patterns were fair. FIGURE 6 shows nozzle spray pattern uniformity for the 110 degree Albus yellow, orange and red nozzle tips. The spray distribution pattern coefficient of variation varied from 12.3 to 20.2%. The nozzles produced unacceptable spray distribution patterns between 15 and 44 psi (100 and 300 kPa). The nozzles had to be operated above 55 psi (379 kPa) to produce acceptable spray distribution patterns. The Spraymaster could not produce nozzles pressures above 55 psi (379 kPa) at application rates above 2.2 gal/ac (25 L/ha).

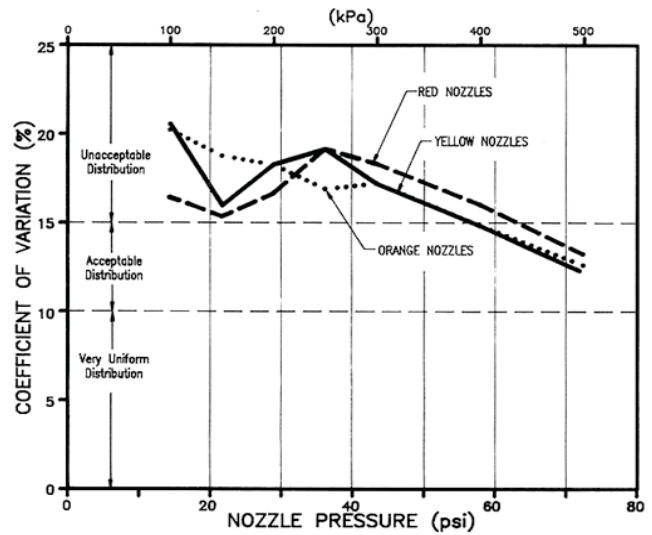

FIGURE 6. Spray Pattern Uniformity for Albus Yellow, Orange and Red 110 Degree Ceramic Nozzles Operated at a 15.7 in (400 mm) Nozzle Height.

FIGURE 7 shows a typical spray distribution pattern along the boom operating Albus red nozzles at a normal nozzle pressure of 43.5 psi (300 kPa) pressure and a 15.7 in (400 mm) nozzle height. The coefficient of variation was 17%, with application rates along the boom varying from 3.1 to 5.7 gal/ac (35 to 64 L/ha). High spray concentrations occurred below the nozzles and was rated unacceptable. It is recommended the manufacturer modify nozzle spacing and height to produce acceptable spray distribution patterns at pressures between 15 and 44 psi (100 to 300 kPa).

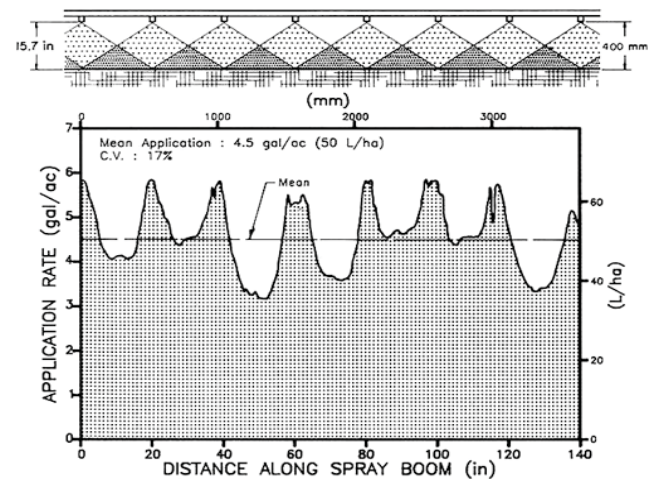

FIGURE 7. Typical Spray Distribution Pattern Along the Boom at a 44 psi (300 kPa) Nozzle Pressure Using Albus Red Ceramic Nozzles, at an 15.7 in (400 mm) Nozzle Height.

**Spray Drift:** A.F.M.R.C. conducted no tests to evaluate spray drift. A spray drift study will be conducted at a later date with the larger Spraymaster model.

**Weed Control:** Weed control was good. General field observations indicated weed control was reduced in and around the wheel tracks, boom leaf spring skids and boom ends. The truck and sprayer wheels created excessive dust. The dust reduced the chemical's effectiveness. FIGURE 8 shows voluntary crop in and around the wheel tracks after spraying the non-selective chemical Sweep on a summerfallow field.



FIGURE 8. Weed Control In and Around Wheel Tracks.

The boom skid and foam discharge hoses interfered with the nozzle spray. The spray interference contributed to the poor weed control in the boom skid and boom end vicinities.

Weed control across the other boom sections were similar to that of conventional sprayers. Some partially affected weeds were found. The partial weed control was attributed to the unacceptable spray distribution patterns produced at 15.7 in (400 mm) spraying height.

**System Pressure:** System pressure variations, losses and nozzle pressure indication accuracy were excessive and rated as fair. Pressures in the plumbing system were measured at the pump, controller and booms using the yellow, orange and red sized nozzles. Nozzle pressures at the left boom were higher than at right boom, resulting in higher application rates (FIGURE 9). The pressure difference was negligible using the low volume yellow nozzles, but significant using the high volume red nozzle tips.

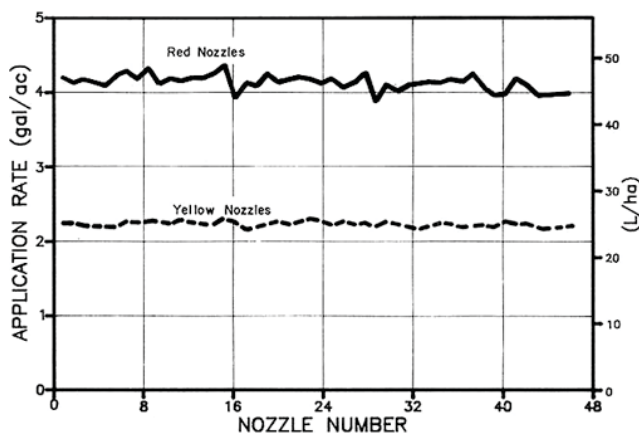

FIGURE 9. Application Rate Along the Boom Using Albus Yellow and Red Nozzle Tips.

The pressure gauge on the sprayer was accurate. The remote control console pressure indicator received with the sprayer was inaccurate and was replaced. The new pressure indicator was accurate and reliable throughout the rest of the test. However, the pressure indicator in the remote control console did not indicate nozzle pressure. This pressure difference affects nozzle spray distribution patterns and droplet size since it was not detected by the sprayer pressure indicator. FIGURES 10 and 11 show actual nozzle pressure and the pressure indicated by the remote control console using the yellow and red nozzles at 2.2 and 4.5 gal/ac (25 and 50 L/ha), respectively. The pressure difference was more significant at the high application rates. For example, at 18.6 mph (30 km/h), the actual nozzle pressure was 30.7 psi (212 kPa) using

the high volume red nozzles. The console pressure indicated 40.6 psi (280 kPa). Therefore the operator had to increase forward speed to operate about 10 psi (70 kPa) higher than indicated to obtain the desired spray nozzle pattern and droplet size. It is recommended the manufacturer make modifications to indicate actual nozzle pressure at the remote console pressure indicator.

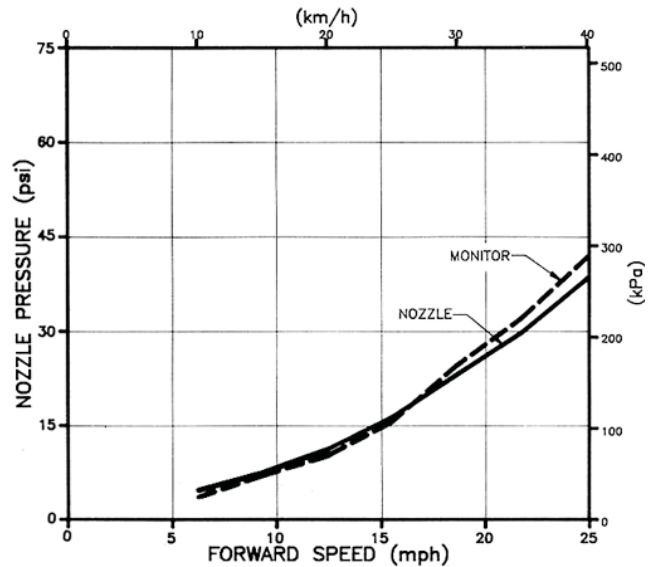

FIGURE 10. Actual Nozzle and Indicated Pressure Using Albus Yellow Nozzles at 2.2 gal/ac (25 L/ha).

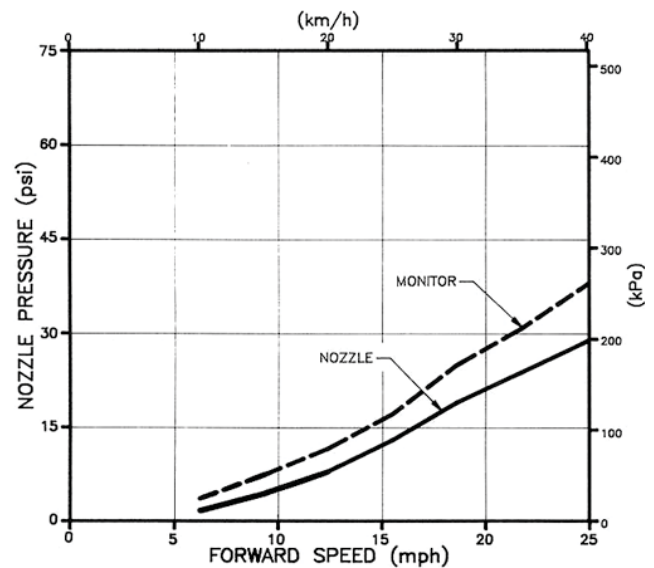

FIGURE 11. Actual Nozzle and Indicated Pressure Using Albus Red Nozzles at 4.5 gal/ac (50 L/ha).

The plumbing system and non-drip nozzle check valve caused a pressure loss. FIGURE 12 shows the system pressure losses using the red nozzles to apply 4.5 gal/ac (50 L/ha). At 18.6 mph (30 km/h) a pressure loss of about 15 psi (100 kPa) occurred from the main boom inlet to the nozzles. The pressure loss did not affect calibration since the application rate was controlled by the automatic rate controller system. However, the pressure loss limited the Spraymaster's capacity to application rates below 4.5 gal/ac (50 L/ha). In addition, the Spraymaster had to be operated at higher speeds than necessary. For example, to obtain 44 psi (300 kPa) the Spraymaster had to be operated at 24 mph (38 km/h) using the red Albus nozzles (Figure 12). This was too fast in the field conditions encountered during the test.

**Use of Optional Nozzles:** Use of optional nozzles was very good. The nozzle assemblies (FIGURE 13) accepted a wide range of Albus nozzle tips, including North American nozzle tips.

**System Strainers:** The Spraymaster strainers were effective and rated as good. The tank filler opening and line strainer were equipped with 18 and 50 mesh strainers, respectively. The 100 mesh nozzle strainers effectively prevented the Albus nozzles

from plugging.

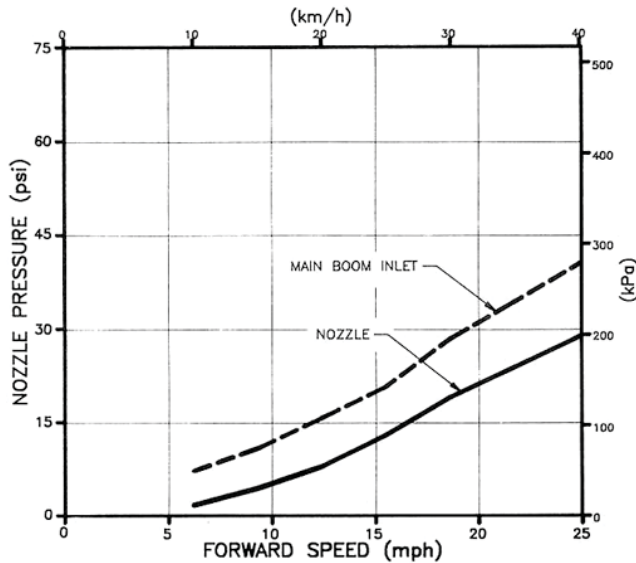

FIGURE 12. Pressure Loss From Boom Line Inlet to Nozzle Tip Using Albuz Red Nozzle Tips at 4.5 gal/ac (50 L/ha).

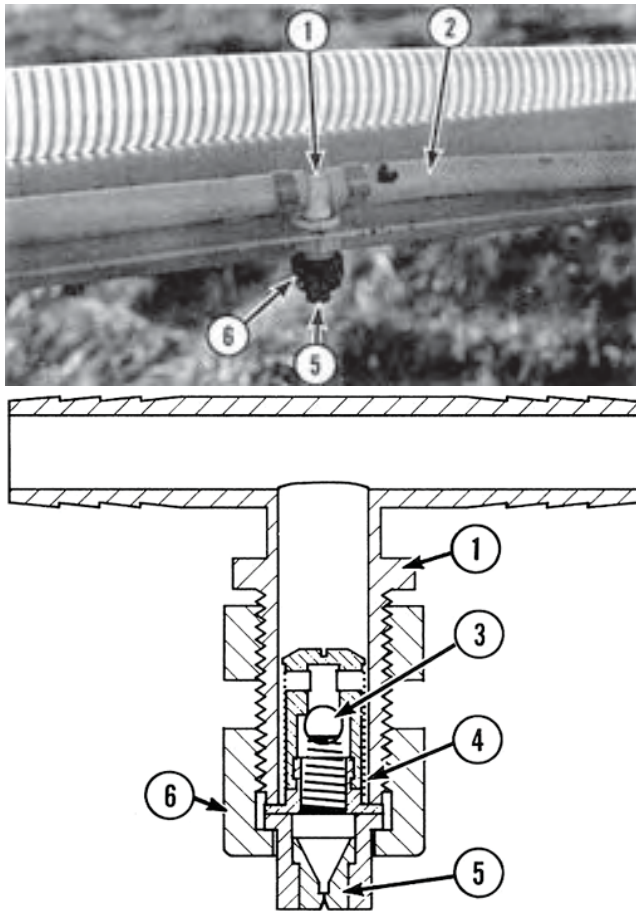

FIGURE 13. Hose Shank Nozzle Assembly: (1) Double Hose Connection (2) Spray Boom, (3) Check Valve, (4) Strainer, (5) Nozzle Tip, and (6) Threaded Nozzle Cap.

The line strainer was self-cleaning and returned the foreign material into the spray tank through the front agitator plumbing. The foreign material usually plugged the front agitator. It is recommended the manufacturer consider modifications to prevent the front agitator from plugging.

**Boom Stability:** The Spraymaster sprayer boom stability was good. Field observations showed the boom spring skid and cable suspension reduced vertical boom movement but not horizontal movement in the field conditions encountered (TABLE 2) during the test. Boom operation across gullies was good.

**Soil Compaction and Crop Damage:** The sprayer trailer

wheels travelled over about 2% of the total field area sprayed. The wheel tread of the trailer was 5.5 ft (1.68 m), matching most large truck wheel treads. Soil contact pressure beneath the trailer wheels was slightly more than the unloaded truck used. The average soil contact pressures under the sprayer and truck wheels with a full tank are given in TABLE 3. Soil contact pressure beneath the rear truck wheels increased 20 psi (138 kPa) with the loaded sprayer. Some crop damage resulted from the rear truck wheels.

TABLE 3. Soil Compaction

	Tire Track Width		*Average Soil Contact Pressure	
	in	mm	psi	kPa
Trailer Wheels	6.7	170	38	262
Truck Wheels				
- front	6.4	163	35	241
- rear	6.7	170	55	379

\*For comparative purposes, the unloaded truck had a soil contact pressure of about 35 psi (241 kPa).

### EASE OF OPERATION AND ADJUSTMENT

**Application Rate:** Ease of adjusting application rate was good. Changing application rate less than 20% was easily done by programming the automatic rate controller. Three different application rates could be programmed and used any time by adjusting the switch. Changing application rates by more than 20% required changing nozzle tips. Changing nozzle tips was time consuming. To prevent operating at excessively high or low speeds and pressures it was important to choose application rates that matched the nozzle tip capacities. The operator's manual provided information on the Albuz yellow and orange nozzle tips.

The Spraymaster sprayer was designed to apply low application rates. Application rates above 5.3 gal/ac (60 L/ha) was the sprayer's limit as shown in FIGURE 2.

**Controls:** Ease of operating the controls was good. The Computronics International remote control and automatic rate controller consoles (FIGURE 14) were designed to operate from the truck seat. The remote control console included a pressure indicator to monitor nozzle pressure and boom solenoid valve switches to control flow to the booms.



FIGURE 14. Computronics International Remote Control (upper) and Automatic Application Rate Controller Consoles (lower).

The Computronic controller was easy to use following the instructions in the operator's manual. The controller displayed application rate, forward speed, tank volume, total area sprayed, trip area and stored five calibration numbers to automatically control application rate. The wheel calibration number was the sprayer wheel circumference. The wheel circumference measurement required another operator to count the wheel revolutions. Once the calibration numbers were entered in the metric mode, readout could be either metric or imperial.

The Computronic controller 4-digit LED display screen was easy to read unless it faced direct sunlight. The push buttons, dials and switches were small and difficult to use in rough field conditions.

The agitator valves and throttle were mounted on the sprayer frame and pump motor, respectively, and could not be operated remotely. The agitator valves were normally fully open during

spraying and only had to be opened once. The motor throttle was used to set the nozzle pressure operating range. A pressure gauge was located near the motor vicinity, which made it easy to adjust operating pressure. The high volume red nozzle tips required the throttle fully open.

Both front and rear tank level indicators had to be read and then averaged to give an indication of liquid level.

**Maneuverability:** Sprayer maneuverability was very good. Ease of towing was very good in both field and transport position. Cornering, backing and transporting with the truck was easy. Turning radius was 32 ft (9.8 m) before the sprayer trailer wheels started skidding. Turning quickly in field position was easy because the skids prevented the booms from striking the ground.

**Boom Positioning:** Ease of boom positioning was good. The Spraymaster booms were folded into transport (FIGURE 15) or placed into field position in about three minutes. Care had to be exercised to prevent getting tangled in the ropes while placing the booms into field position. One boom had to be secured on the boom rest pad before folding or unfolding while placing the other boom. The boom had to be completely lifted off the rest pad to prevent nozzle body damage (FIGURE 16).



FIGURE 15. Spraymaster in Transport Position.



FIGURE 16. Damaged Nozzle Assembly.

The boom ends had a breakaway feature that returned to the normal spraying position after striking an object.

**Nozzle Adjustments:** Ease of adjusting nozzle angle and height was poor. Nozzle angle could not be adjusted. Adjusting nozzle height was difficult and took over half an hour. The boom height adjustment assembly would bind, making it difficult to lower or lift the boom. Heavy tools were necessary.

Adjustment to nozzle height required adjustments to the boom skids and suspension cables. For proper boom stability the boom skids were adjusted to just touch the ground. This also prevented the boom skids from pivoting during spraying. The boom cables and ropes were adjusted to level the booms from end to end, provide proper boom suspension and to set the booms perpendicular to the sprayer trailer.

Nozzle height could be adjusted from about 15 to 22 in (381 to 559 mm). Due to difficulty adjusting boom height, time consumed and limited height range, the adjustment was avoided. It is recommended the manufacturer consider modifications to make it easier to adjust nozzle height.

The Spraymaster was equipped with hose shank nozzle assemblies which made nozzle changing time consuming. Unscrewing 48 nozzle caps and aligning the nozzle tips at the proper angle was inconvenient and time consuming.

**Tank Filling:** Ease of filling the spray tank was good. The operator normally used the reload hose to fill the 483 gal (2196 L) spray tank. A nurse tank equipped with a transfer pump was required. A 2 in (51 mm) supply hose was needed to fit the reload hose quick coupler provided. Reloading through the spray tank filler opening by gravity was difficult since the filler opening was 6.6 ft (2.0 m) above the ground. Time required to fill the spray tank averaged about 20 minutes.

**Chemical Inducting:** Ease of adding chemical to the spray tank was good. The Spraymaster was equipped with a chemical inductor wand. It took about 20 to 50 seconds to empty a 2.2 gal (10 L) chemical container, depending on chemical viscosity and volume of fluid in the spray tank. About 10.6 oz (300 mL) of chemical drained back to the chemical container after the chemical inductor wand valve was closed. Care was exercised to prevent chemical draining on the operator.

Chemical could be added any time and preference depended on operator skill, time and chemical susceptibility to foaming. Inducting chemical during reloading water reduced reloading time, but was inconvenient since the chemical induction wand, main valve and reload plumbing were located away from each other. The chemical induction system did not provide a means of rinsing chemical containers. Rinsing chemical containers consumed the most time during reloading and was considered a hazard.

The chemical induction wand stored high on the foam marker tank and was difficult to remove and insert. In addition, the bottom portion of the wand was handled when removing or inserting the wand, exposing the operator to the chemical residue (FIGURE 17).



FIGURE 17. Operator Using Chemical Inductor Wand.

**Hitching:** Ease of hitching the Spraymaster sprayer to a truck was very good. A Binkley hitch pin and plate assembly had to be installed on the tow truck. The hitch jack provided was safe. The fifth wheel was easy to hitch and was adjustable to level the spray tank trailer. Levelling the trailer was difficult since the entire fifth wheel assembly had to be loosened and supported carefully. Hitching also included the hook-up of three electronic couplers.

**Cleaning:** Ease of cleaning was very good. The main line was equipped with a self-cleaning strainer that flushed into the spray tank. The debris settled on the bottom of the front sump and was removed through the drain line during flushing of the spray tank. Removing nozzle caps from the hose shank nozzle assemblies to clean the strainers was time consuming. The nozzle strainers and plugged nozzle tips were easily cleaned using the compressed air



system hose. The spray tank was easily flushed using the reload line.

**Draining:** Ease of draining the spray tank was very good. The drain line valve located at the side of the spray tank trailer was easily accessible. The spray tank completely drained through the drain line.

The pump cavity drained by removing the bottom screw on the pump housing. Draining the boom lines was easily done by opening the cock valves at the boom ends.

**Servicing:** Ease of servicing the pump motor was good. The oil dip stick, gasoline cap and air filter were easily accessible. Draining the motor oil was inconvenient because an oil pan could not be placed between the oil drain plug and motor base to collect the oil.

Ease of lubricating the sprayer was good. The Spraymaster had 5 pressure grease fittings that were easily accessible. Lubrication frequency was not indicated in the operator's manual. The trailer wheel bearings required repacking each season.

### PUMP PERFORMANCE

**Output:** The Hypro 9203C centrifugal pump output was very good. The Spraymaster was designed to apply low volumes of water, and the pump output was adequate using the low volume Albus yellow and orange nozzle tips.

Pump output was fair at application rates above 3.6 gal/ac (50 L/ha), due to reduced pump speeds. Pump speeds reduced because the motor labored at the high application rates and pressures.

The centrifugal pumps output decreases rapidly with small reductions in pump speed. FIGURE 18 shows how pump speed varied using the red and yellow nozzles at various application rates and forward speeds.

Higher application rates and forward speeds were possible by closing-off the agitation.

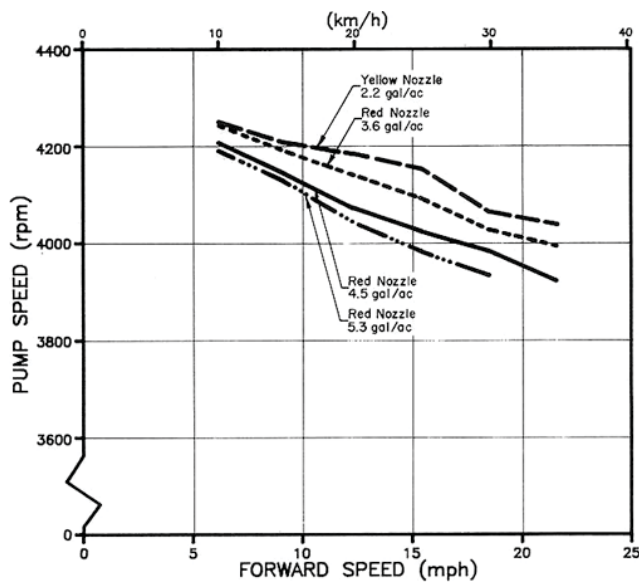

FIGURE 18. Pump Speed at Various Application Rates and Forward Speeds.

**Agitation:** Agitation output was very good. The Spraymaster sprayer was equipped with two vertically mounted, jet agitators. TABLE 4 shows agitator outputs during various operating conditions using the 0.16 in (4 mm) diameter orifices. Agitation rates varied depending on pump speed. During field spraying pump speed varied from 3920 to 4250 rpm. Maximum agitation rates occurred with the agitator valves opened.

TABLE 4. Agitator Outputs

Operating Condition	Pump Speed	Agitator Output	
	rpm	gal/min	L/min
Reloading	4320	18.5	84
Field Spraying	3920	16.3	74
	4250	17.6	80

Agitator output exceeded the recommended agitation rates for emulsifiable concentrates and wetttable powders. Normally

recommended agitation rates for emulsifiable concentrates such as 2,4-D are 1.5 gal/min per 100 gal of tank capacity (1.5 L/min per 100 L of tank capacity). For wetttable powders such as Atrazine, recommended agitation rates are 3.0 gal/min per 100 gal of tank capacity (3.0 L/min per 100 L of tank capacity).

At high agitation rates, foaming may occur with some chemicals. However, the agitation rate could easily be reduced by partially closing the agitator valve.

### MOTOR PERFORMANCE

The Kawasaki Model FA 210 gasoline motor performance was fair. Several pulls of the starter cord were necessary to start the motor. The cord failed once and the motor quit several times during field operation. Though not recommended, the low oil level switch was disconnected to reduce the number of times the motor quit operating. The motor speed decreases at the high application rates and forward speeds, limiting the sprayer to lower volume applications.

Average fuel consumption was about 0.37 gal/h (1.69 L/h). The operator could spray for about 1.6 hours or 153 ac (62 ha) at 16 mph (26 km/h) before refuelling. For convenience, the motor was refuelled each time the spray tank was refilled. Oil consumption was insignificant.

### MARKER PERFORMANCE

**Mark Visibility:** Mark visibility was very good in the field conditions encountered. The Spraymaster foam marker left continuous marks of pink foam (FIGURE 19) that were easy to see and to align with the end of the spray boom. Mark spacing and length could not be controlled or varied. Foam mark spacing and length varied from about 2 to 10 ft (0.6 to 3.0 m) and 3 to 10 in (76 to 254 mm) respectively.

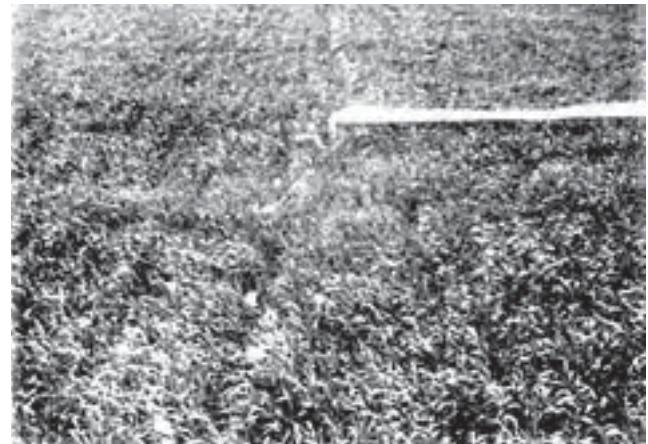

FIGURE 19. Spraymaster Foam Marks.

**Mark Durability:** Mark durability was fair. The foam marks lasted about 30 minutes, but less than 10 minutes in hot windy conditions. This was adequate at the high spraying speeds but the marks were not useful following a brief stop or after reloading.

**Quantity of Foam Used:** About 200 ac (81 ha) could be sprayed at 17 mph (27 km/h) with one tank of soap concentrate and water solution. More acres could be sprayed by completely emptying the foam tank, but foam mark spacing, size and durability deteriorated. Therefore, the foam tank was usually refilled below the 10 gal (45 L) level. This increased the amount of foam concentrate used.

Operating cost for the foam concentrate was about 10 cents/ac (25 cents/ha).

**Filling:** Ease of filling the 38 gal (262 L) foam tank (FIGURE 1) was fair. A hammer was required to remove the foam tank cap. The 2 in (25 mm) diameter nurse tank transfer hose was supposed to be used to fill the tank but was too large and awkward to handle, and filled the foam tank too quickly, causing excessive foaming and spillage. A pail and funnel was used instead but had to be lifted to the sprayer platform and then to the top of the foam tank. The whole procedure was difficult and time consuming.

Adding water or foam concentrate to the foam tank caused foaming and usually spilled on the operator. The colored foam

concentrate left unsightly stains on the sprayer and operator. It is recommended the manufacturer consider modifying the foam marker system to improve operator convenience when filling with water and foam concentrate.

**Controls:** Ease of operating the foam controls was good. The foam tank control valve was normally always opened during spraying. The valve had to be closed when spraying stopped. The control valve was located on the right side of the sprayer and took the operator some time to get there from the left side of the truck. Usually a large quantity of foam was lost before the control valve could be closed.

A toggle switch inside the truck cab controlled foam to the boom end foam hoses. A distance of over 100 ft (30 m) was travelled before foam discharged from the boom end after switching foam sides. As a result, there usually were no marks at the field headlands, were switching occurred the most.

**OPERATOR SAFETY**

The operator’s manual emphasized operator safety. The pump drive system was well shielded. The Spraymaster was equipped with a chemical inductor wand, compressed air system and fresh water container, which reduced operator exposure to chemical.

Care had to be exercised when adjusting the fifth wheel height adjustment to prevent the assembly from moving.

**Caution:** Operators are cautioned to wear suitable eye protection, respirators and clothing to minimize operator contact with chemicals. Although many commonly used agricultural chemicals appear to be relatively harmless to humans, they may be deadly. In addition, little is known about the long-term effects of human exposure to many commonly used chemicals. In some cases, the effects may be cumulative, causing harm after continued exposure over a number of years.

**OPERATOR’S MANUAL**

The operator’s manual was good. It provided useful information on safety, machine components, sprayer operation, maintenance, adjustments, trouble shooting, and parts. Additional information on nozzle size, droplet size, delivery rates and application rates would be beneficial to the operator.

**MECHANICAL PROBLEMS**

TABLE 5 outlines the mechanical history of the Spraymaster during 73 hours of operation while spraying about 4167 ac (1687 ha). The intent of the test was evaluation of functional performance. An extended durability evaluation was not conducted.

TABLE 5. Mechanical History

Item	Hours	Equivalent Field Area	
		ac	(ha)
<b>Plumbing</b>			
-the line strainer relief valves leaked and the caps tightened		throughout the test	
-the left boom solenoid valve leaked and was removed and refitted	9	540	(219)
-the line strainer valve broke and was replaced at	8, 30	540, 1720	(219, 696)
-the line strainer valve leaked and was tightened at	23, 30	1440, 1720	(583, 696)
-the remote control console master switch broke and the console replaced at	13	740	(300)
-the right boom solenoid valve wire broke and was repaired at	22	1440	(583)
-the pump discharge hose came off and was reconnected at	30	1720	(688)
-the chemical inductor wand broke and was repaired at	34	2020	(818)
<b>Motor</b>			
-the motor start rope and bell failed and were replaced at	54	3029	(1226)
-the motor stalled frequently throughout the test and was replaced at	81	3394	(1370)
-the system pressure decreased frequently and the agitator valves were operated closed to increase system pressure using the red nozzles		throughout the test	
<b>Trailer</b>			
-the spray tank vent lid was lost and replaced at	2, 30	100, 1720	(40, 696)
-the right walking beam grease fitting was loose and tightened at	30	1720	(696)
<b>Booms</b>			
-the boom skid collars loosened and were retightened at	11, 61, 381	640, 2340, 3384	(259, 947, 1370)
-the nozzle hose shank assembly broke and was replace at	9, 30	540, 1720	(219, 696)

**DISCUSSION OF MECHANICAL PROBLEMS**

**Plumbing:** The line strainer vents and plumbing components (FIGURE 20) leaked despite frequent attempts of removing and retightening the components. In addition, the light duty valve failed

twice. To prevent delays in spraying the plumbing was modified using galvanized plumbing components. It is recommended the manufacturer modify the line strainer plumbing components to prevent leaking and valve failure.

The chemical inductor wand elbow failed. The chemical inductor wand was difficult to manoeuvre into a chemical container since the hose restricted movement, causing the PVC elbow to fail. It is recommended the manufacturer modify the chemical inductor wand for easier handling and better durability.

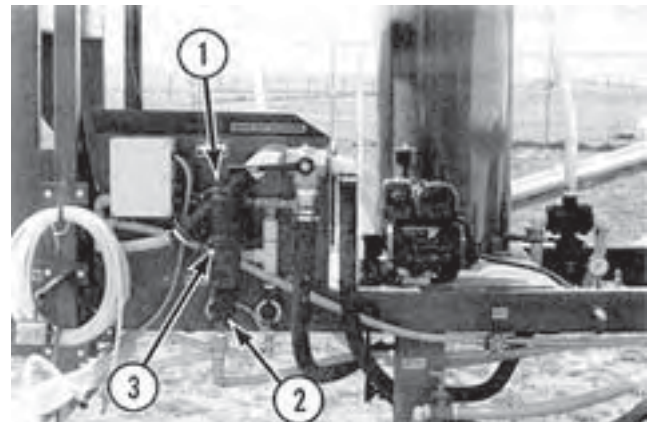

FIGURE 20. Line Strainer Plumbing Components: (1) Vent Caps, (2) Light Duty Valve, (3) Self-Cleaning Strainer.

**Booms:** The boom skid lock collars loosened several times during field testing. During transport the top collar loosened, sheared the pin and resulted in the skid falling off the boom. It is recommended the manufacturer modify the boom skid assembly to prevent the lock collars from loosening.

**Motor:** The motor frequently stalled during spraying, especially during turning, spraying over rough and dusty field surface conditions and applying high rates. The motor air filter was cleaned during each reloading to reduce motor stalling. The motor start cord required several pulls before the motor started, which further frustrated the operator. The start cord failed. It is recommended the manufacturer consider modifying the motor to prevent stalling and improve starting.

**APPENDIX I  
SPECIFICATIONS**

**MAKE:** Spraymaster  
**MODEL:** GN 40-60  
**SERIAL NUMBER:** C035 4 060 88  
**MANUFACTURER:** SPRAYMASTER CANADA INC.  
P. O. Box 100  
Spirit River, Alberta  
T0H 3G0

**OVERALL DIMENSIONS:**  
-- wheel tread 5.54 ft (1.69 m)  
-- wheel base 3.13 ft (0.95 m)  
-- transport height 8.73 ft (2.66 m)  
-- transport length 25.8 ft (7.89 m)  
-- transport width 8.46 ft (2.58 m)  
-- field height 8.73 ft (2.66 m)  
-- field length 22.2 ft (6.8 m)  
-- field width 63.0 ft (19.2 m)  
-- clearance height 12 in (305 mm)  
-- turning radius 32.4 ft (9.9 m)

**TIRES:**  
-- trailer four, 9 - 15LT, 6-ply thread

**WEIGHT:**

	<u>Empty</u>	<u>Loaded</u>
-- left front	470 lb (214 kg)	1660 lb (755 kg)
-- left rear	760 lb (346 kg)	2070 lb (942 kg)
-- right front	490 lb (223 kg)	1560 lb (710 kg)
-- right rear	750 lb (341 kg)	2070 lb (942 kg)
-- hitch	680 lb (309 kg)	1010 lb (460 kg)
<b>TOTAL</b>	<b>3150 lb (1433 kg)</b>	<b>8360 lb (3804 kg)</b>

	<u>Empty</u>	<u>Loaded</u>
-- left front	400 lb (182 kg)	1540 lb (701 kg)
-- left rear	700 lb (319 kg)	2080 lb (946 kg)
-- right front	420 lb (191 kg)	1550 lb (705 kg)
-- right rear	740 lb (337 kg)	1950 lb (887 kg)
-- hitch	890 lb (405 kg)	1240 lb (564 kg)
<b>TOTAL</b>	<b>3150 lb (1433 kg)</b>	<b>8360 lb (3804 kg)</b>

**SPRAY TANK:**  
-- material fiberglass  
-- capacity 483 gal (2196 L)  
-- agitation hydraulic, 0.125 in (3.2 mm) orifices

**FILLER OPENING:**  
-- shape round  
-- size  
--small 4.75 in (121 mm) I.D.  
--large 15.75 in (400 mm) I.D.  
-- location top rear  
-- height above ground 6.6 ft (2.0 m)

**CHEMICAL INDUCTOR:**  
-- type hand held wand  
-- size 1 in (25 mm) PVC pipe

**STRAINERS:**  
-- pump outlet one, 50 mesh  
-- nozzle assembly forty eight, 100 mesh  
-- spray tank one, 18 mesh

**PUMP:**  
-- make Hypro  
-- type centrifugal  
-- operating speed 3900 to 4400 rpm  
-- type of drive belt

**MOTOR:**  
-- make Kawasaki  
-- model FA 210  
-- power 5 hp (3.8 kW)  
-- fuel capacity 0.6 gal (2.7 L)

**CONTROL MONITOR:**  
-- make Computronics International Ltd.  
-- model  
--remote SB 1068  
--controller SB 1096  
-- pressure electronic, 0-73.5 psi (0-500 kPa)

**SOLENOID VALVES:**  
-- make Texas Industrial Remcor Inc.  
-- model 204  
-- size two, 1 in (25.4 mm) NPT 12 VDC

**SPRAY BOOM:**  
-- material reinforced plastic hose  
-- size 0.75 in (19.1 mm) I.D.  
-- height adjustment  
--type manual, sliding assembly  
--range 15 to 22 in (381 to 559 mm)  
-- angle adjustment none  
-- nozzle assembly  
--male Spraying Systems  
--type hose shank  
--number 48  
--spacing 15.75 in (400 mm)  
--cap threaded  
--effective spraying width 63 ft (19.2 m)

**APPENDIX II  
MACHINE RATINGS**

The following rating scale is used in PAMI Evaluation Reports:

Excellent	Very Good
Good	Fair
Poor	Unsatisfactory

## SUMMARY CHART

### SPRAYMASTER MODEL GN 40-60 FIELD SPRAYER

<b>RETAIL PRICE:</b>	\$19,700.00 (Nov. 1989, f.o.b. Lethbridge)
<b>RATE OF WORK:</b>	94 to 168 ac/h (38 to 68 ha/h) @ 12 to 22 mph (20 to 35 km/h)
<b>QUALITY OF WORK:</b>	
Application Rate	<b>very good</b> ; controller compensates for speed
Nozzle Calibration	
-delivery	<b>very good</b> ; within 2% of rated
-wear	<b>excellent</b> ; after 110 hours
Coefficient of variation	<b>very good</b> ; about 1.5%
Spray Distribution	<b>fair</b> ; acceptable above 55 psi (379 kPa)
Weed Control	<b>good</b> ; reduced in wheel and skid tracks
Pressure	
-loss	<b>fair</b> ; reduced sprayer capacity
-indicator	<b>fair</b> ; did not indicate nozzle pressure
Straining	<b>good</b> ; effective, but agitator orifice plugged
Boom Stability	<b>good</b> ; vertical movement reduced
Soil Contact Pressure	
-trailer tires	38 psi (262 kPa)
-truck front tires	35 psi (241 kPa)
-truck rear tires	55 psi (379 kPa), caused some crop damage
<b>EASE OF OPERATION AND ADJUSTMENT:</b>	
Application Rate	<b>good</b> ; programmed in controller
Controls	<b>good</b> ; needed wheel circumference measurement
Maneuverability	<b>very good</b>
Boom Positioning	<b>good</b> ; manual, about 3 minutes
Nozzle Adjustments	<b>poor</b> ; nozzle height assembly binded
Tank Filling	<b>good</b> ; needed transfer pump
Chemical Inducting	<b>good</b> ; valves too far apart
Hitching	<b>very good</b> ; hitch jack was safe and hitching was adjustable
Cleaning	<b>very good</b> ; self-cleaning strainer and compressed air system
Draining	<b>very good</b>
Lubrication	<b>very good</b> ; 5 grease points
<b>PUMP PERFORMANCE</b>	
Output	<b>very good</b> ; below 3.6 gal/ac (40 L/ha)
Agitation	<b>very good</b>
<b>MOTOR PERFORMANCE:</b>	
Power	<b>good</b> ; lacked power at application rates greater than 3.6 gal/ac (40 L/ha)
Fuel Consumption	0.37 gal/h (1.69 L/h)
Service	<b>good</b> ; changing oil was messy
<b>MARKER PERFORMANCE:</b>	
Mark Visibility	<b>very good</b>
Mark Durability	<b>fair</b> ; normally about 30 minutes
Quantity of Foam Used	
-area marked	200 ac (81 ha) per tank
-cost	10 cents/ac (25 cents/ha)
Filling	<b>fair</b> ; excessive foaming
Control	<b>good</b> ; control valve too far from operation
Mark Placement	<b>very good</b> ; in calm winds
<b>OPERATOR SAFETY:</b>	equipped with safety accessories to reduce operator exposure to chemicals
<b>OPERATOR'S MANUAL:</b>	<b>good</b> ; useful information
<b>MECHANICAL HISTORY:</b>	skid collars frequently loosened, motor start cord broke and line strainer valve failed twice



3000 College Drive South  
 Lethbridge, Alberta, Canada T1K 1L6  
 Telephone: (403) 329-1212  
 FAX: (403) 329-5562  
<http://www.agric.gov.ab.ca/navigation/engineering/afmrc/index.html>

### Prairie Agricultural Machinery Institute

Head Office: P.O. Box 1900, Humboldt, Saskatchewan, Canada S0K 2A0  
 Telephone: (306) 682-2555

Test Stations:  
 P.O. Box 1060  
 Portage la Prairie, Manitoba, Canada R1N 3C5  
 Telephone: (204) 239-5445  
 Fax: (204) 239-7124

P.O. Box 1150  
 Humboldt, Saskatchewan, Canada S0K 2A0  
 Telephone: (306) 682-5033  
 Fax: (306) 682-5080