

# Evaluation Report

# 361

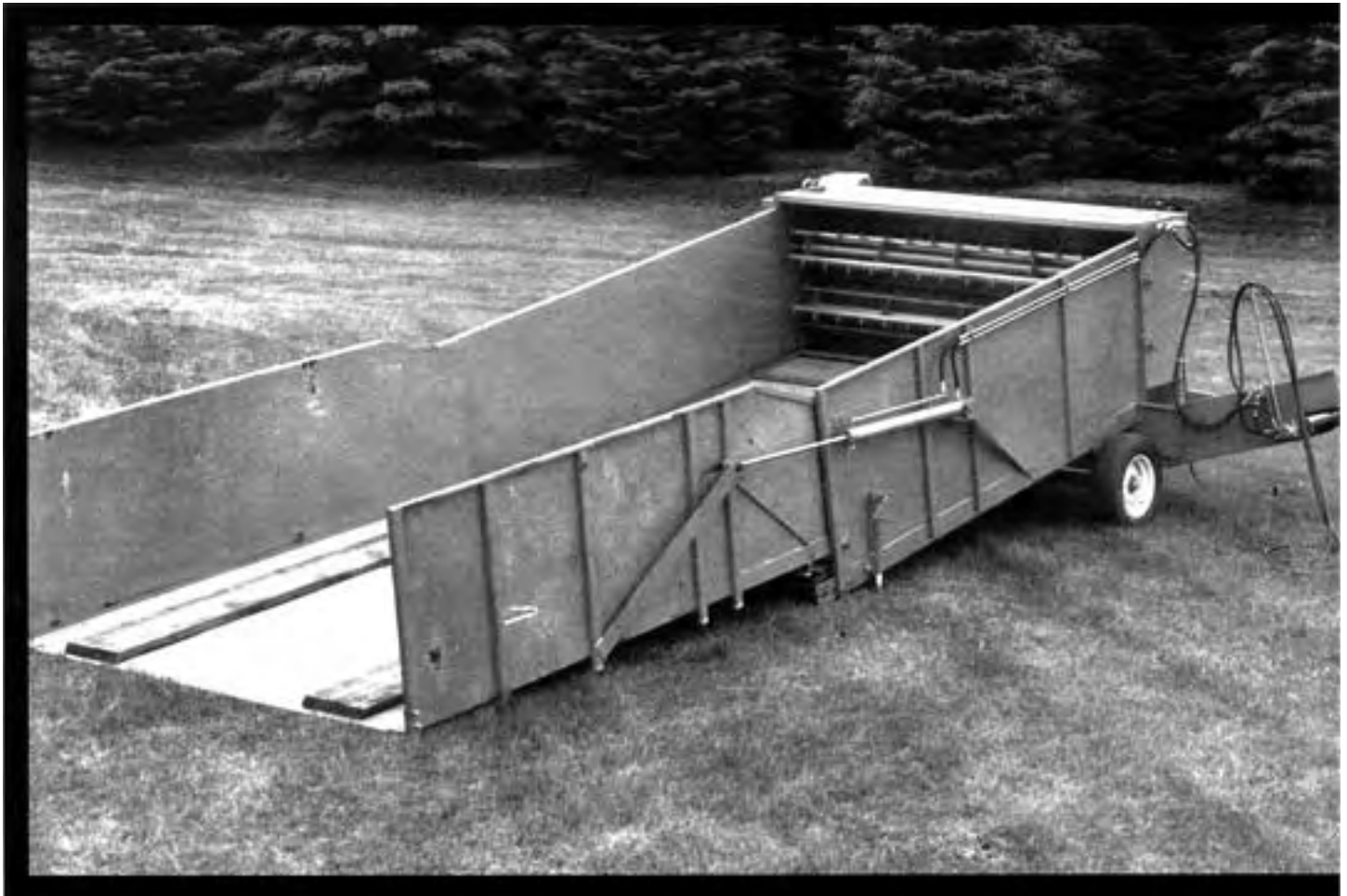

## Jiffy BLD Forage Deck

A Co-operative Program Between



## JIFFY BLD FORAGE DECK

### MANUFACTURER AND DISTRIBUTOR:

Kuelker's Manufacturing  
Box 160  
Didsbury, Alberta

### RETAIL PRICE:

\$10,850 (April 1984, f.o.b. Portage la Prairie, Manitoba)

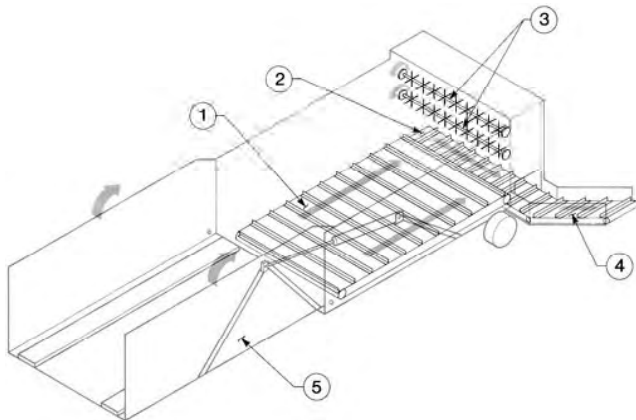

FIGURE 1. Jiffy Forage Deck: (1) Main Deck Conveyor, (2) Cross Conveyor, (3) Beaters, (4) Cross Conveyor Extension, (5) Tilt Ramp.

### SUMMARY AND CONCLUSIONS

**Quality of Work:** Capacity of the forage deck was several times that of the forage blowers used during the tests. The conveyors and beaters were very aggressive in all crops. The forage deck took several minutes to clean with the high speed setting of the main deck conveyor<sup>1</sup>.

The Jiffy was difficult to position at the silo. Some controls were inconveniently located and difficult to use.

**Power Requirements:** The Jiffy was electrically and hydraulically driven. It required a hydraulic flow of 10 gal (US)/min (38 L/min) at 1500 psi (10,000 kPa). The beaters and main deck conveyor were powered with a 5 hp electric motor.

**Safety:** No safety decals were installed on the forage deck and safety recommendations were not included in the operator manual.

**Operator Manual:** A suitable operator manual was not supplied.

**Durability:** Two minor durability problems occurred during the test.

### RECOMMENDATIONS

It is recommended that the manufacturer consider:

1. Modifications to simplify transport and positioning of the forage deck.
2. Relocating the tilt ramp spool valve to allow convenient operation.
3. Improving the design of the main deck conveyor clutch lever to prevent jumping out of position and relocate it to allow convenient operation.
4. Supplying a perforated pipe above the beaters to facilitate the addition of water to legume forage.
5. Modifications to the cross conveyor extension to alleviate spillage.
6. Installing a ladder or step to allow the operator to safely observe the main deck conveyor and beaters.
7. Installing safety decals and including safety instructions in an operator manual.
8. Include an operator manual with information on installation, operation and safety.
9. Supplying tires rated for applied loads.
10. Modifying the hitch and drawpole to prevent bending.

Senior Engineer: G.M. Omichinski

Project Engineer: C.W. Chapman

### THE MANUFACTURER STATES THAT:

With regard to recommendation number:

1. The nature of the machine makes it difficult to transport and position. The machine was not designed to be transported any farther than within the farmstead.
2. We felt that the position of the tilt ramp valve would serve both right hand and left hand delivery units quite well. The operator should be somewhere close by the tractor and in the back of the Bio-Deck, which means that he would be a maximum of 10 feet from the valve.
3. The conveyor clutch has been improved.
4. No changes have been made but it is a good idea. This has never been suggested as a problem.
5. This has been modified.
6. We will consider a ladder.
7. A safety warning is included on the first page of the Operator's Manual, although no decals have been installed on the machine.
8. An operator's manual has been supplied with the machine for 2 years.
9. A 9.25" x 16", 8-ply tire used, is now standard.
10. Again, we do not recommend that the machine be towed on the highway. It is strictly an "on the farm" tool.

### GENERAL DESCRIPTION

The Jiffy is an electrically and hydraulically driven forage deck, which is used to convey forage from dump trucks to forage blowers. Forage, which is dumped from the trucks into the deck is transferred to the main conveyor by a tilting ramp. Two beaters transfer the forage to a cross conveyor.

FIGURE 1 shows the location of the major components and detailed specifications are given in APPENDIX I.

### SCOPE OF TEST<sup>2</sup>

The Jiffy was operated for 45 hours while conveying alfalfa, clover and corn silage. It was evaluated for rate of work, power requirements, ease of operation and adjustment, operator safety and suitability of the operator manual.

### RESULTS AND DISCUSSION

#### RATE OF WORK

The capacity of the forage deck was limited by the conveying rate of the forage blower used for the tests. Capacity of the forage deck and blower system ranged from 27 to 40 ton/h (24 to 36 t/h). The forage deck itself was capable of a conveying rate several times these capacities. The maximum speed of the main deck conveyor was 3.6 ft/min (1.1 m/min) and therefore required several minutes to clear any forage remaining in the deck.

#### POWER REQUIREMENTS

The Jiffy Forage Deck is hydraulically and electrically driven. It requires a hydraulic flow of 10 gal (US)/min (38 L/min) at a pressure of 1500 psi (10,000 kPa) to operate the tilt ramp and cross conveyor.

The tractor should have a minimum hydraulic reserve capacity of 1.0 gal (U.S.) (3.8 L), to meet the requirements of the two double acting cylinders on the tilt ramp.

The beaters and main deck conveyor were driven by a 5 hp (3.75 kW) 220 volt electric motor.

Total power requirement for the forage deck was 14 hp (10.5 kW).

#### EASE OF OPERATION AND ADJUSTMENT

**Positioning:** Proper alignment of the cross conveyor with the blower hopper was necessary to avoid spillage. Two adjustable jacks aided in leveling the forage deck. The wheels, tilt ramp and main deck should be blocked up to reduce movement, keep the deck level, and reduce the load on the hitch jacks.

The Jiffy forage deck was difficult to position at the silo. The

<sup>1</sup>See Machine Ratings APPENDIX II

<sup>2</sup>Prairie Agricultural Machinery Institute Detail Test Procedure for Forage Decks.

tilt ramp must be in the raised position and the drawpole attached before the unit could be moved. The cross conveyor rested on the ground when the drawpole was attached to a tractor drawbar. This required removing the cross conveyor to move the forage deck. The Machinery Institute increased the axle height to facilitate positioning of the forage deck.

It is recommended that the manufacturer consider modifications to simplify positioning of the forage deck.

**Controls:** The operation of the Jiffy was controlled with two hydraulic valves, and a clutch lever.

One hydraulic valve controlled the cross conveyor and a spool valve operated the tilt ramp. The cross conveyor valve was convenient and easy to use. The tilt ramp spool valve, which was located on the rear of the deck was difficult to reach. It is recommended that the manufacturer relocate the spool valve to allow convenient operation.

The main deck conveyor and beaters were powered with an electric motor. A suitable switch was not included with the deck but should be installed in a convenient location to control the motor.

The clutch lever controlled the speed of the main deck conveyors by means of a belt tightening idler pulley and a variable speed sheave. The clutch lever was located at the right rear of the deck and was difficult to reach especially when the deck was assembled to unload to the left.

Several times during the test the clutch lever jumped to the high speed setting. It is recommended that the manufacturer improve the design of the main deck conveyor clutch lever and relocate the lever to allow convenient operation.

**Tilt Ramp:** The tilt ramp operated smoothly and evenly throughout the test and was capable of hoisting an 8 ton (7.2 t) load of forage. Considerable operator vigilance was necessary when backing a truck into the 9.4 ft (2.9 m) wide tilt ramp. Wheel stops were bolted onto the ramp to avoid the truck wheels or end gate from striking the main deck conveyor and that the tilt ramp spool valve was left in float position to eliminate any load on the hydraulic cylinders when backing loaded trucks on to the ramp.

**Beaters:** The Jiffy was equipped with two beaters which fed the forage to the cross conveyor. The beaters were aggressive in all crops. The beater speed was constant. Some gumming occurred on the beaters when conveying legume forage. The addition of water above the beaters alleviated the problem. It is recommended that the manufacturer consider supplying a perforated pipe above the beaters to facilitate the addition of water to legume forage.

It was difficult for the operator to observe the main deck conveyor and beaters when standing beside the forage deck. It is recommended that the manufacturer install a ladder or step to allow the operator to safely observe the main deck conveyor and beaters.

**Cross Conveyor and Extension:** The constant speed cross conveyor effectively moved forage to the blower. Some spillage occurred at the joint between the cross conveyor and cross conveyor extension. It is recommended that the manufacturer consider modifications to alleviate spillage problems.

**Adjustments:** Few adjustments were needed during the 50 hour test. The conveyor chains were easily adjusted.

**Lubrication:** The Jiffy had ten pressure grease fittings, six drive chains and six conveyor chains which required lubrication.

**Transporting:** The Jiffy trailed well at speeds below 10 mph (16 km/h). It was necessary to remove the cross conveyor when transporting because of ground clearance.

Extreme caution had to be exercised when transporting due to a transport width of 14.1 ft (4.3 m) and height of 13.3 ft (4.1 m) (FIGURE 2).

The tires supplied with the Jiffy forage deck were overloaded by 30 and 39%<sup>3</sup>. It is recommended that the manufacturer supply tires, which are rated for the applied loads.

The deck had to be emptied of all material and a suitable safety chain attached. A pick-up truck with a minimum gross vehicle weight of 7500 lbs (3400 kg) was required to transport the Jiffy due to a hitch weight of 1637 lbs (744 kg).

During transport, the drawpole was permanently bent at the clevis hitch. It is recommended that the manufacturer modify the hitch and drawpole to prevent bending.



FIGURE 2. Transport Position.

## OPERATOR SAFETY

Safety decals were not installed on the Jiffy to warn of hazardous areas, and safety recommendations were not included in the operator manual. It is recommended that the manufacturer consider installing safety decals and include safety recommendations in an operator manual.

## OPERATOR MANUAL

A suitable operator manual was not available. It is recommended that the manufacturer include an operator manual with information regarding installation, operation and safety.

## DURABILITY RESULTS

TABLE 1 outlines the mechanical history of the Jiffy forage deck. The intent of the test was evaluation of functional performance. An extended durability test was not conducted.

TABLE 1. Mechanical History

Item	Operating Hours
The drawpole bent and was repaired at	Beginning of test 10
The skid shoes on the main deck bent and were reinforced at	

<sup>3</sup>Tire & Rim Association 1982 Yearbook

**APPENDIX I  
SPECIFICATIONS**

**MAKE:** Jiffy  
**MODEL:** BLD  
**SERIAL NUMBER:** 666-82

**WEIGHTS:**  
 -- left rear wheel 2077 lbs (944 kg)  
 -- right rear wheel 2222 lbs (1010 kg)  
 -- hitch point 1637 lbs (744 kg)  
 total 5936 lbs (2698 kg)

**TRANSPORT POSITION DIMENSIONS:**  
 -- maximum length 19.1 ft (5.8 m)  
 -- maximum width with cross conveyor up 14.1 ft (4.3 m)  
 -- maximum height 13.3 ft (4.1 m)  
 -- ground clearance 0 in (0 mm)  
 -- hitch height 18 in (460 mm)

**FIELD POSITION DIMENSIONS:**  
 -- maximum length 26.6 ft (8.1 m)  
 -- maximum width with cross conveyor down 15.3 ft (4.7 m)  
 -- maximum height 7.0 ft (2.1 m)

**TIRES:** two, P225 R70-15, 4-ply

**COMPONENT SPEEDS:** (at hydraulic flow of 17.1 gal (US)/min (65 L/min))  
 -- Beaters  
 -upper 220 rpm  
 -lower 280 rpm  
 -- Conveyors  
 -cross conveyor 4.3 ft/sec (1.32 m/sec)  
 -main deck conveyor 0.04 to 0.06 ft/sec (0.0109 to 0.0186 m/sec)  
 2.1 to 3.6 ft/min (0.7 to 1.1 m/min)

**BEATER DIAMETER:**  
 -- upper 8.5 in (215 mm) lower 8.5 in (215 mm)

**MAIN DECK CONVEYOR:**  
 -- width two, 4.6 ft (1.4 m) type Pintle chain

**CROSS CONVEYOR:**  
 -- width 23 in (585 mm) type Pintle chain

**MAIN DECK DIMENSIONS:**  
 -- height 3.7 ft (1.1 m)  
 -- width 9.6 ft (2.9 m)  
 -- length 12.0 ft (3.7 m)

**TILT RAMP DIMENSIONS:**  
 -- height 3.7 ft (1.1 m)  
 -- width 9.5 ft (2.9 m)  
 -- length 12.0 ft (3.7 m)

**APPENDIX II  
MACHINE RATINGS**

The following rating scale is used in Machinery Institute Evaluation Reports:  
 Excellent Fair  
 Very Good Poor  
 Good Unsatisfactory

**APPENDIX III  
CONVERSION TABLE**

Acre (ac) x 0.405	= Hectare (ha)
Foot (ft) x 0.305	= Metre (m)
Inches (in) x 25.4	= Millimetres (mm)
Horsepower (hp) x 0.746	= Kilowatt (kW)
Miles Hour (mph) x 1.61	= Kilometre/Hour (km/h)
Pounds Force (lb) x 4.45	= Newton (N)
Pounds Force/Foot (lb/ft) x 14.6	= Newton Metre (Nm)
Pounds Force-Feet (lb ft) x 1.36	= Newton Metre (N-m)
Pounds Force/Square Inch (psi) x 6.89	= Kilopascal (kPa)
Pounds Mass (lb) x 0.454	= Kilogram (kg)
Tons Mass (ton) x 0.91	= Tonnes (t)
Gallon (US) (gal (US)) x 3.8	= Litre (L)
Gallon (US)/minute (gal (US)/min) x 3.8	= Litre/Minute (L/min)

## SUMMARY CHART

### JIFFY FORAGE DECK

<b>RETAIL PRICE:</b>		\$10,850.00 (April 1984, f.o.b. Portage la Prairie, Man.)
	<b>Rating</b>	<b>Comments</b>
<b>QUALITY OF WORK</b>		
Capacity	<b>Very Good</b>	limited by capacity of forage blower used in the tests.
Cleaning	<b>Good</b>	high speed setting took several minutes to clean deck.
<b>EASE OF OPERATION AND ADJUSTMENT</b>		
Positioning	<b>Fair</b>	tilt ramp must be raised to position. limited ground clearance.
Controls	<b>Fair</b>	some controls difficult to reach.
Cross Conveyor	<b>Good</b>	some spillage between cross conveyor & cross conveyor extension.
<b>OPERATOR SAFETY</b>	<b>Fair</b>	no caution decals were provided.
<b>OPERATOR MANUAL</b>	<b>Fair</b>	a suitable operator manual was not supplied.
<b>POWER REQUIREMENTS</b>		14 hp (10.5 kW) hydraulically & electrically driven.

#### CAUTION

This summary chart is not intended to represent all of the final conclusions of the evaluation report. The relevance of the ratings is secondary to the information provided in the full text of the report. It is not recommended that a purchase decision be based only on the summary chart.



3000 College Drive South  
Lethbridge, Alberta, Canada T1K 1L6  
Telephone: (403) 329-1212  
FAX: (403) 329-5562  
<http://www.agric.gov.ab.ca/navigation/engineering/afmrc/index.html>

#### Prairie Agricultural Machinery Institute

Head Office: P.O. Box 1900, Humboldt, Saskatchewan, Canada S0K 2A0  
Telephone: (306) 682-2555

Test Stations:  
P.O. Box 1060  
Portage la Prairie, Manitoba, Canada R1N 3C5  
Telephone: (204) 239-5445  
Fax: (204) 239-7124

P.O. Box 1150  
Humboldt, Saskatchewan, Canada S0K 2A0  
Telephone: (306) 682-5033  
Fax: (306) 682-5080