

Evaluation Report

439

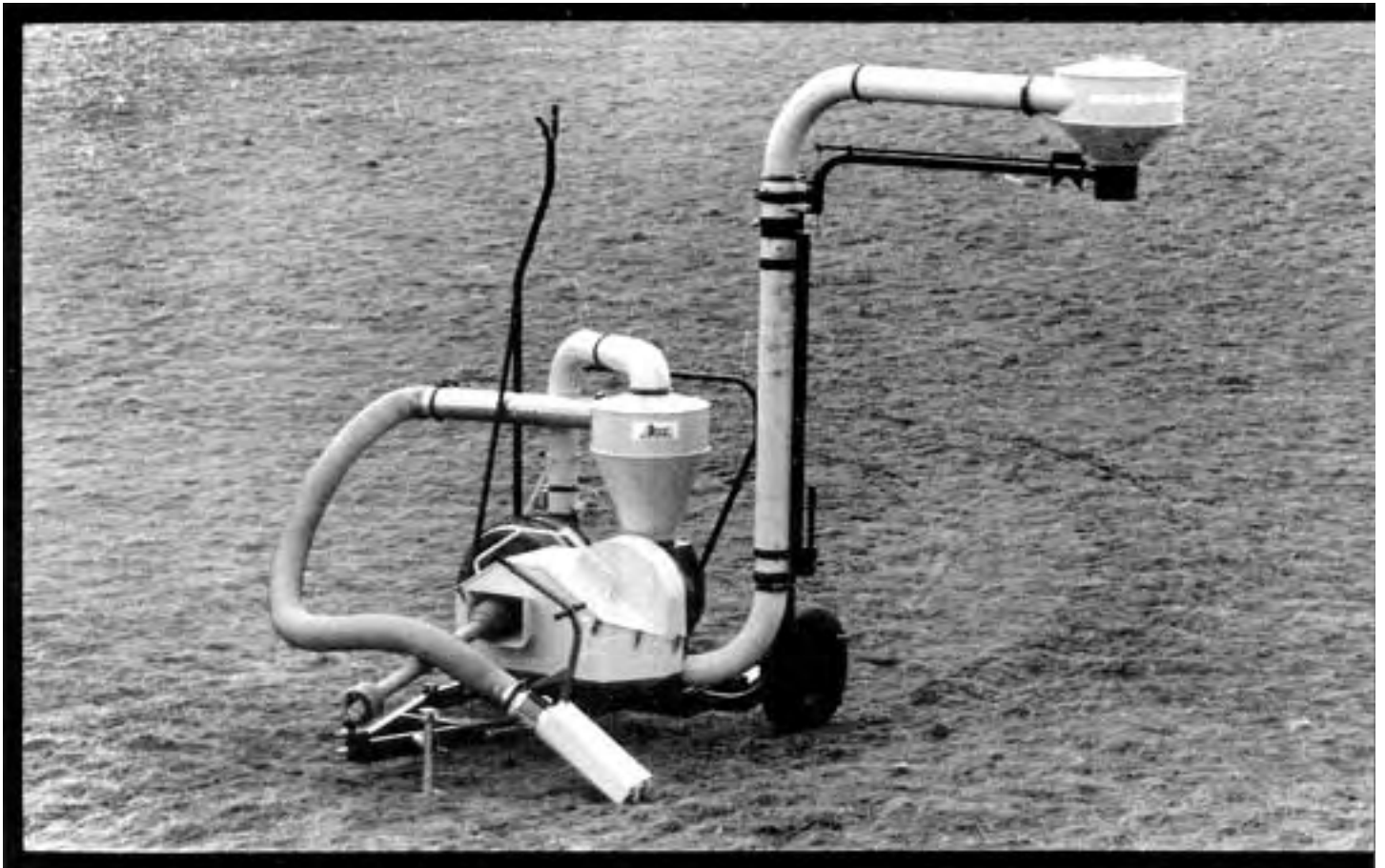

Kongsilde Suc 500 TR2 Suction Blower

A Co-operative Program Between



KONGSKILDE SUC 500 TR2 SUCTION BLOWER

MANUFACTURER:

Kongskilde Limited
P.O. Box 880
Thames Road East
Exeter, Ontario
N0M 1S0

DISTRIBUTOR:

Alteen Distributors Limited
P.O. Box 6450 Wetaskiwin, Alberta
T9A 2G2

RETAIL PRICE:

\$11,632.00 (June, 1985, f.o.b. Lethbridge, Alberta).

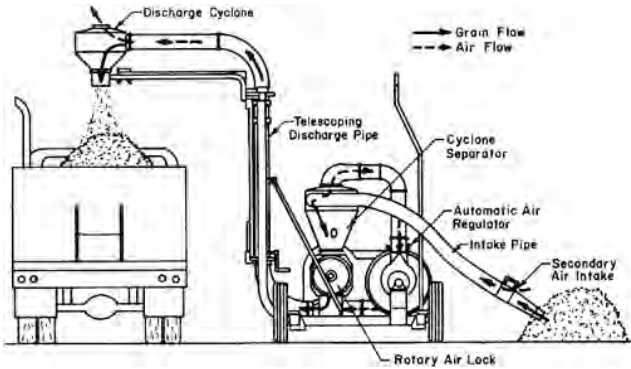

FIGURE 1. Schematic View Showing Air and Grain Flow.

SUMMARY AND CONCLUSIONS

The maximum conveying rates obtained with the Kongskilde SUC 500 TR2 were 1370 bu/h (37.2 t/h) for wheat, 1740 bu/h (37.9 t/h) for barley and 2460 bu/h (55.8 t/h) for canola. Conveying rates were reduced when intake or discharge pipe lengths were increased.

Power requirements while conveying grain varied from 47 to 50 hp (35 to 37.5 kW). A tractor with maximum power take-off output of at least 70 hp (52 kW) was required due to high starting torques.

The specific capacity of an average 8 in (200 mm) diameter grain auger was six times greater than that of the Kongskilde SUC 500 TR2 in wheat and two times greater in canola. This indicates that pneumatic conveying of grain is inefficient in terms of power required for the amount of grain moved when compared to a grain auger. However, pneumatic conveyors have advantages a grain auger doesn't have. For example, they are capable of conveying grain over longer distances, both vertically and horizontally, than is possible with a grain auger.

Crackage in dry wheat was about 0.1% for each pass through the Kongskilde SUC 500 TR2. This is similar to damage caused by grain augers. However, observations indicated that crackage was high in dry canola. Passes through the machine should therefore be kept to a minimum.

The intake nozzle was fairly easy to maneuver during bin clean-out when using the flexible vinyl clean-out hose. Complete clean-out could be accomplished with the intake nozzle but it was found easier to sweep or push the grain towards the spout laying in its horizontal position.

The jack assembly and telescoping discharge pipe allowed the discharge cyclone to be conveniently placed into transport position onto the support bar provided.

The Kongskilde SUC 500 TR2 was much safer to use than a grain auger, especially for cleaning grain bins. Working near the inlet nozzle was clean as most dust was conveyed into the inlet. It was also safer than an auger since the operator was exposed to fewer moving parts. Noise levels adjacent to the conveyor varied from 94 to 96 dBA when operating in open areas. When operating close to metal bins the noise level was loud and irritating. It is recommended that an operator wear suitable ear protection when working near the Kongskilde SUC 500 TR2.

No mechanical failures occurred during the test.

RECOMMENDATIONS

It is recommended that the manufacturer consider:

1. Modifying the detachable handle to make connection to the intake nozzle easier.
2. Modifying the intake nozzle to provide for improved maneuverability during bin clean-out.
3. Supplying a slow moving vehicle sign as standard equipment.
4. Supplying a more complete operator's manual containing information on safety, operation, and adjustments.

Senior Engineer: E. H. Wiens

Project Engineer: L. W. Papworth

THE MANUFACTURER STATES THAT

With regard to recommendation number:

1. & 2. The existing "universal suction head" will be replaced by two more efficient nozzles. One will be designed for maximum capacity and the other for optimum convenience during clean-up activities.
3. A slow moving vehicle sign will be standard equipment in the future.
4. A new operators manual is currently being compiled and will contain more explicit information regarding operation, adjustment and safety aspects of the machine.

GENERAL DESCRIPTION

The Kongskilde SUC 500 TR2 is a 540 rpm, power take-off driven pneumatic grain conveyor, mounted on a two wheel trailer. The three stage centrifugal blower (FIGURE 1) provides both suction and discharge air to convey grain without passing it through the blower. Grain is conveyed by the intake airstream through the intake nozzle through the cyclone separator and into the rotary air lock. It then passes through the air lock into the discharge airstream, which delivers it to the discharge cyclone.

The blower is driven from the power take-off shaft by a multi V-belt pulley arrangement. The rotary air lock is driven from the power take-off by two V-belts.

Intake and discharge locations can be varied by adding elbows and sections of 6.3 in (160 mm) diameter rigid pipe and 6.0 in (150 mm) or 6.3 (160 mm) diameter flexible pipe. The rigid pipe is galvanized metal tubing while the flexible pipe is available in steel, vinyl or polyethylene.

FIGURE 1 shows the location of major components while detailed specifications are given in APPENDIX 1.

SCOPE OF TEST

The Kongskilde SUC 500 TR2 was used for 21.5 hours to convey the various grains shown in TABLE 1. It was evaluated for ease of operation and adjustment, rate of work, power requirements, quality of work, operator safety and suitability of the operator's manual.

TABLE 1. Operating Conditions

Material	Quantity Conveyed		Hours
	bu	t	
Spring Wheat	8267	225	9.0
Canola	4762	108	7.0
Barley	6568	143	5.5
TOTAL	19597	476	21.5

RESULTS AND DISCUSSION

EASE OF OPERATION AND ADJUSTMENT

Standard Discharge: The standard discharge assembly (FIGURE 2) was a truck loading kit and consisted of two 90° elbows, a 3.3 ft (1 m) length of pipe and a telescoping pipe mounted on a jack assembly. The assembly allowed the discharge cyclone to rotate 280 degrees around the vertical discharge pipe and the discharge height to vary from 9.3 to 13.8 ft (2.8 to 4.2 m). This discharge height and the 5.3 ft (1.6 m) reach would easily accommodate all common truck box sizes but was insufficient for filling grain bins.

Conveying Pipes: Rigid pipe sections were available in 1, 3.3 and 6.6 ft (0.3, 1.0 and 2.0 m) lengths. The flexible steel pipe was

available in 6.8 ft (2.1 m) lengths. A 12.5 (3.8 m) length of polyethylene hose and a 5.4 ft (1.6 m) length of flexible vinyl hose were supplied for use in bin clean-out. The flexible vinyl hose was for use in connecting directly to the intake spout to increase maneuverability during bin floor clean-up. Adjacent pipes and elbows were joined with quick couplers. Flow directions could be changed by using 90°, 45°, 30° and 15° elbows.

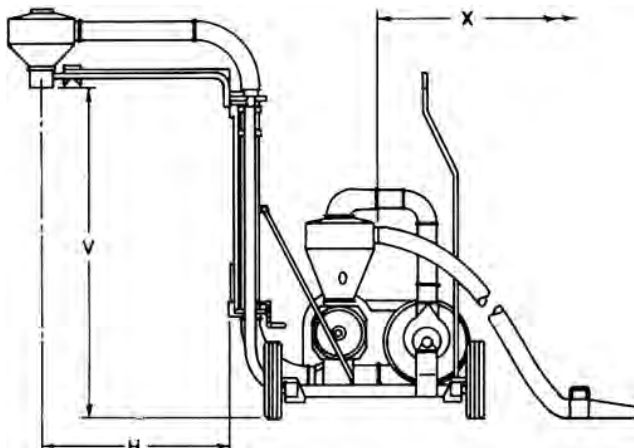

FIGURE 2. Standard Discharge Assembly: V = 13.8 ft (4.2 m), H = 5.3 ft (1.6 m).

Intake Nozzle: Only one type of intake nozzle was available. The flat steel 12 lb (5.4 kg) nozzle (FIGURE 3) was used for normal grain conveying as well as bin clean-out. An adjustable sleeve was provided to conveniently vary the amount of intake air. A detachable handle (FIGURE 4) was provided to aid in bin clean-out. The same clamp was used to hold both the handle in place and the pipes together. This made attaching the handle awkward. It is recommended that the manufacturer consider modifying the detachable handle to make connection to the intake nozzle easier.

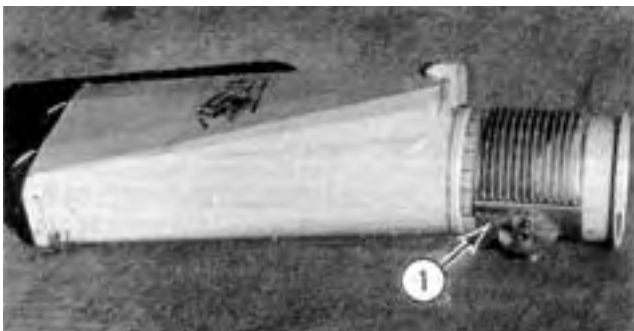

FIGURE 3. Intake Nozzle: (1) Adjustable Sleeve.

The intake nozzle was designed to lay flat on the floor. However, to clean a bin floor completely the spout had to be tilted downwards (FIGURE 4). Due to the weight and design of the handle, this was hard to do for extended periods of time. It was found easier to sweep or push the grain towards the spout in its flat position. Additionally, the flexible intake pipe was rigidly fastened to the intake nozzle,

making it difficult to maneuver in a bin. It is recommended that the manufacturer consider modifications to provide for improved maneuverability during bin clean-out.



FIGURE 4. Position of Intake Nozzle to Clean Bin Floor Completely: (1) Flexible Vinyl Hose, (2) Clamp, (3) Detachable Handle.

Transporting: The Kongskilde SUC 500 TR2 could be easily placed in transport position (FIGURE 5). The telescoping discharge pipe and jack assembly allowed the discharge cyclone to be conveniently swung over the conveyor and lowered onto the support bar for transporting. A locking brake (FIGURE 6) secured the discharge assembly in position. The Kongskilde was very stable in transport position and could be safely towed at speeds up to 40 mph (60 km/h).

The Kongskilde SUC 500 TR2 was also supplied with a frame (FIGURE 6) made specifically for holding four, 6.6 ft (2 m) sections of pipe. The sections of pipe could not be secured to the pipe frame, so this method of transporting pipe could only be used when transporting at slow speeds over short distances.



FIGURE 5. Kongskilde SUC 500 TR2 in Transport Position: (1) Support Bar, (2) Jack Assembly.

Hitching: The Kongskilde SUC 500 TR2 was easily hitched to tractors with a 540 rpm power take-off. The hitch jack was convenient. The hitch clevis was not adjustable to suit varying tractor drawbar heights. Consequently, the conveyor could not be adjusted to operate level with all tractors used.

Adjustments: All belts could be easily tightened and all pulleys easily aligned with the available adjusting rods. Belts were tightened according to manufacturer's specifications using the tension tester supplied.



FIGURE 6. (1) Frame for Holding Pipe, (2) Locking Brake.

Secondary air flow into the intake nozzle could be easily varied with the adjustable sleeve provided (FIGURE 3). The sleeve was easily rotated to vary the secondary air opening. The size of opening was conveniently indicated by a scale from 1 to 8 on the intake nozzle.

Servicing: The Kongskilde SUC 500 TR2 had five grease fittings on the power take-off shaft and two seals on the air lock that had to be oiled. The Kongskilde could be serviced in less than 10 minutes.

RATE OF WORK

Maximum Conveying Rates: Conveying rates for the Kongskilde SUC 500 TR2 depended on the type of grain being conveyed, the secondary air setting on the intake nozzle and the length of intake and discharge pipe.

The conveying rate was very dependent on maintaining a steady flow rate. Highest conveying rates were obtained when the intake nozzle was completely submerged in grain, using one length of steel flexible pipe on the intake and the standard discharge assembly (FIGURE 2). As shown in TABLE 2, the maximum conveying rates were 1370 bu/h (37.2 t/h) in wheat, 1740 bu/h (37.9 t/h) in barley and 2460 bu/h (55.8 t/h) in canola. The wide range of conveying rates in TABLE 2 indicates the difficulty in adjusting the intake nozzle air opening to obtain maximum conveying rates.

Secondary Air Setting: The amount of secondary air introduced at the intake nozzle was important in obtaining maximum conveying rates. Too little secondary air caused the conveyor to surge. Too much secondary air resulted in inefficient conveying due to reduced suction at the intake. The secondary air setting depended on the density of the material being conveyed and length of conveying pipe. For example, FIGURE 7 indicates the effect of secondary air setting on the conveying rate in wheat, using the standard intake and discharge assembly. The optimum scale setting was 3.25, which resulted in a conveying rate of 1370 bu/h (37.2 t/h). Maximum conveying rates obtained at optimum secondary air settings coincided closely with maximum conveying rates indicated by the automatic air regulator (FIGURE 1). Therefore, the operator could conveniently adjust the secondary air setting by using the indicator on the automatic air regulator.

Effect of Pipe Length: Conveying rates decreased with increased intake pipe length. For example, increasing the intake pipe length from 10 to 100 ft. (3.0 to 30.5 m) (FIGURE 8) reduced the maximum conveying rate from 1370 to 1090 bu/h (37.2 to 29.6 t/h) in wheat, from 1740 to 1310 bu/h (37.9 to 28.6 t/h) in barley and from 2460 to 1240 bu/h (55.8 to 28.2 t/h) in canola.

Increasing the discharge pipe length also reduced the conveying rate. The standard discharge assembly had a reach of 5.1 ft (1.55 m). Increasing the discharge pipe length to 100 ft (30.5 m) (FIGURE 9) reduced the conveying rate from 1370 to 1030 bu/h (37.2 to 28.1 t/h) in wheat, from 1740 to 1370 bu/h

(37.9 to 30.0 t/h) in barley and from 2460 to 1450 bu/h (55.8 to 32.8 t/h) in canola.

TABLE 2. Conveying Rates at 540 rpm Power Take-Off Speed

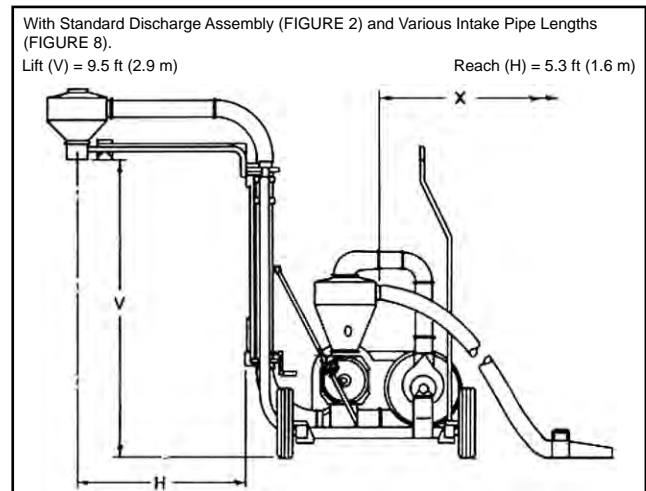

One Length of Flexible Intake Pipe and Various Discharge Pipe Lengths (FIGURE 9). Lift (V) = 9.5 ft (2.9 m)

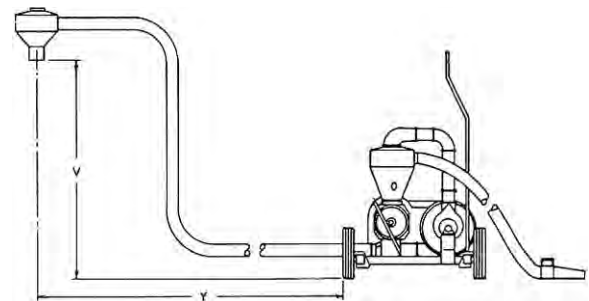

Grain	Intake Pipe Length (X)			Discharge Pipe Length (Y)	
	10.0 ft (3.1 m)	50.0 ft (15.2 m)	100 ft (30.5 m)	50.0 ft (15.2 m)	100 ft (30.5 m)
Wheat	1200-1370 bu/h (32.7-37.2 t/h)	1080-1170 bu/h (29.3-31.7 t/h)	940-1090 bu/h (25.6-29.6 t/h)	1050-1220 bu/h (28.6-33.1 t/h)	940-1030 bu/h (25.6-28.1 t/h)
Barley	1480-1740 bu/h (32.3-37.9 t/h)		1175-1310 bu/h (25.6-28.6 t/h)		1160-1370 bu/h (25.2-30.0 t/h)
Canola	2160-2460 bu/h (49.1-55.8 t/h)		970-1240 bu/h (22.0-28.2 t/h)		1150-1450 bu/h (26.1-32.8 t/h)

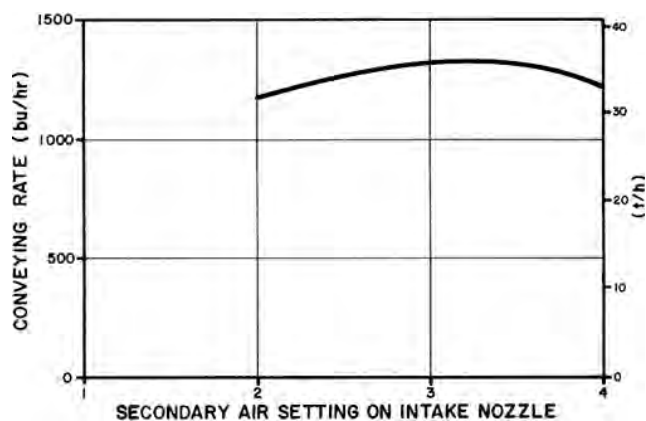

FIGURE 7. Conveying Rates in Wheat for Various Secondary Air Settings.

Effect of Pipe Type: Conveying rates were greater when using rigid pipe and elbows (FIGURE 10) instead of the standard steel flexible inlet pipe (FIGURE 2). The maximum conveying rate in wheat increased from 1370 to 1605 bu/h (37.2 to 43.7 t/h) when using the rigid pipe intake assembly.

Conveying rates decreased when the polyethylene hose was attached for bin clean-out. The maximum conveying rate in wheat decreased from 1370 to 950 bu/h (37.2 to 25.9 t/h) when using the 12.5 ft (3.8 m) polyethylene hose. Conveying rates for the

polyethylene hose in other grains are given in TABLE 3.



FIGURE 8. Increased Intake Pipe Length.



FIGURE 9. Increased Discharge Pipe Length.



FIGURE 10. Rigid Pipe Intake Assembly.

Effect of Pipe Couplers: During trial capacity runs it was noticed that the quick pipe couplers supplied were, in some cases, not completely air tight. This was because the pipe ends were out of round and the edges did not line up. When connecting two pipes, the operator had to make sure the pipe ends were round so the fit was air tight. Leaks on the suction side could decrease the capacity

significantly while leaks on the pressure side did not significantly decrease capacity.

TABLE 3. Conveying Rates with Polyethylene Hose Attached to Standard Intake

Grain	Wheat	Barley	Canola
	740 to 950 bu/h (20.1 to 25.9 t/h)	930 to 1300 bu/h (20.3 to 28.3 t/h)	940 to 1070 bu/h (21.4 to 24.3 t/h)

Comparison to a Grain Auger: TABLE 4 compares the performance of the Kongskilde SUC 500 TR2 to that of an average 8 in (200 mm) diameter, 50 ft (15.2 m) long grain auger at 30° inclination with a lift of 24 ft (7.3 m). Data for the Kongskilde SUC 500 TR2 was obtained with the standard discharge and 10 ft (3.0 m) standard intake. The maximum conveying rate for the Kongskilde SUC 500 TR2 was 43% less than the grain auger in spring wheat and 18% more than the grain auger in canola.

TABLE 4. Comparison of the Kongskilde SUC 500 TR2 to an Average 8 in (200 mm) Diameter Grain Auger¹

Grain Type	Maximum Conveying Rates				Specific Capacities			
	Kongskilde		Grain Auger		Kongskilde		Grain Auger	
	bu/h	t/h	bu/h	t/h	ton/hph	t/kWh	ton/hph	t/kWh
Wheat	1370	37.2	2393	65.3	0.87	1.06	5.1	6.2
Canola	2460	55.8	2087	47.3	1.24	1.51	2.9	3.4

Specific capacity (the amount of grain moved per unit of power in a specific period of time) can be used to compare the two methods of grain handling. A high specific capacity indicates an efficient use of energy while a low specific capacity indicates inefficient energy usage. The specific capacity for the grain auger was six times greater than that of the Kongskilde SUC 500 TR2 in wheat and two times greater in canola. This indicates that pneumatic conveying is inefficient as compared to augering grain. However, pneumatic conveyors have advantages that grain augers do not have. They are capable of conveying grain over longer distances, both vertically and horizontally, than is possible with a grain auger. Pneumatic conveyors are also safer to operate than grain augers.

POWER REQUIREMENTS

The maximum power take-off input for the Kongskilde SUC 500 TR2 was from 47 to 50 hp (35 to 37.5 kW). The highest power requirement occurred when conveying air only. As grain was conveyed, less air was pumped, slightly reducing the power requirement.

Start-up torques for the Kongskilde SUC 500 TR2 were very high. Engaging the power take-off slowly at the lowest possible idle speed reduced initial power requirements. Because of high starting torques and peak requirements during plugging, a minimum tractor size of 70 hp is recommended.

QUALITY OF WORK

Grain Damage: FIGURE 11 shows the increase in grain crackage each time a sample of dry wheat (12.5% moisture content) was conveyed. In these tests, the Kongskilde SUC 500 TR2 was equipped with the standard discharge assembly (FIGURE 2) and one length of steel flexible pipe. The wheat initially contained 0.7% cracks. Each pass through the Kongskilde caused an average of 0.1% increase in crackage. This indicates that if the number of passes is kept to a minimum, grain damage should not be a problem. Test results from grain augers in dry wheat have shown that each pass through an auger causes less than 0.2% crackage.

Laboratory tests were not performed on the crackage caused by the Kongskilde SUC 500 TR2 in canola. However, field observations indicate that the damage was considerable if the sample was dry. When using the Kongskilde to convey dry canola, the number of passes through the machine should be kept to a minimum.

Plugging: Plugging occurred when insufficient air entered the inlet to carry the material being conveyed. Proper adjustment of the secondary air inlet was essential to prevent plugging.

Plugging could also occur if too much material was introduced during bin clean-out. The Kongskilde SUC 500 TR2 could be

¹Grain auger data represents average data results from Machinery Institute Test Reports 319, 320, 321.

unplugged by discontinuing grain intake and allowing air to clear the blockage.

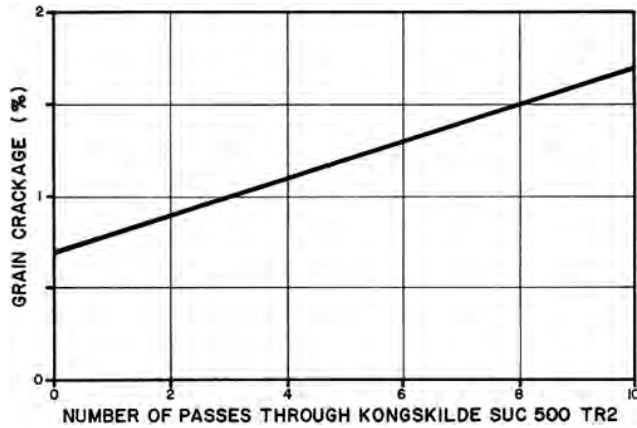

FIGURE 11. Grain Crackage in Dry Wheat.

OPERATOR SAFETY

The Kongskilde SUC 500 TR2 was safe to operate as all rotating parts were well shielded. The intake nozzle was much safer to operate than a grain auger since there was no exposed flighting or rotating parts. Working near the intake nozzle was virtually dust-free since most dust was conveyed into the inlet. Working near the discharge cyclone was, however, very dusty.

Noise levels near the Kongskilde SUC 500 TR2 when powered with a 110 hp (82 kw) tractor varied from 94 to 96 dBA when operating on flat open fields. Noise levels when operating near metal bins, or in enclosed areas, became very loud and irritating. It is recommended that an operator wear suitable ear protection when working near the Kongskilde SUC 500 TR2.

The Kongskilde SUC 500 TR2 in transport position was low enough to pass safely under power lines. Its 7.3 ft (2.2 m) transport width allowed for safe road transport.

No slow moving vehicle sign was provided on the Kongskilde SUC 500 TR2. It is recommended that the manufacturer supply a slow moving vehicle sign as standard equipment.

OPERATOR'S MANUAL

Assembly instructions and a complete parts list were provided. The operator's manual was, however, lacking in detailed information on operation, adjustments and safety. For example, there were no detailed directions in the manual for preparing the conveyor for transport. These directions were only given on a sticker attached to the machine. It is recommended that the manufacturer supply a more complete operator's manual containing information on safety, operation, and adjustments of the Kongskilde SUC 500 TR2.

MECHANICAL PROBLEMS

The Kongskilde SUC 500 TR2 was operated for 21.5 hours. The intent of the test was evaluation of functional performance, and an extended durability evaluation was not conducted. No mechanical problems were encountered during the test.

**APPENDIX I
SPECIFICATIONS**

MAKE:	Kongskilde	
MODEL:	SUC 500 TR2	
SERIAL NUMBER:	1001545	
MANUFACTURER:	Kongskilde Limited P.O. Box 880 Thames Road East Exeter, Ontario N0M 1S0	
DIMENSIONS:	<u>Field Position</u>	<u>Transport Position</u>
-- overall length	9.7 ft (2.9 m)	9.7 ft (2.9 m)
-- overall width	13.5 ft (4.1 m)	7.3 ft (2.2 m)
-- overall height	11.6 ft (3.5 m)	11.6 ft (3.5 m)
-- wheel tread	5.7 ft (1.7 m)	5.7 ft (1.7 m)
INTAKE & DISCHARGE PIPES:	6.0 in (150 mm) diameter 6.3 in (160 mm) diameter flexible hose 6.3 in (160 mm) diameter rigid pipe	
FLEXIBLE PIPE:	<u>Length</u>	<u>Weight</u>
-- vinyl	5.3 ft (1.6 m)	9.3 lb (4.2 kg)
-- polyhose	12.5 ft (3.8 m)	24.0 lb (10.9 kg)
-- steel	6.9 ft (2.1 m)	28.0 lb (12.7 kg)
RIGID PIPE:	6.6 ft (2.0 m)	16.1 lb (7.3 kg)
	3.3 ft (1.0 m)	7.9 lb (3.6 kg)
	1.0 ft (0.3 m)	2.9 lb (1.3 kg)
INTAKE NOZZLE:	31 in (775 mm)	12 lb (5.5 kg)
Discharge Height:	<u>Maximum</u>	<u>Minimum</u>
Reach:	13.8 ft (4.2 m)	9.3 ft (2.8 m)
	5.3 ft (1.6 m)	
NUMBER OF LUBRICATION POINTS:	5 grease fittings 2 seals	
DRIVES:	540 rpm multi V-belt multi V-belt	
DISCHARGE CYCLONE:	39 lb (17.7 kg)	
TIRES:	2, tubeless, 185 SR14	
WEIGHT:	<u>Field Position</u>	<u>Transport Position</u>
-- right wheel	410 lb (185 kg)	540 lb (245 kg)
-- left wheel	915 lb (415 kg)	785 lb (355 kg)
-- hitch	495 lb (225 kg)	495 lb (225 kg)
TOTAL	1820 lb (825 kg)	1820 lb (825 kg)
CENTRE OF GRAVITY:	29.6 in (741 mm)	28.9 in (723 mm)
-- above ground	27.6 in (689 mm)	27.2 in (680 mm)
-- forward of trailer axle	23.4 in (586 mm)	27.9 in (697 mm)
-- in from left wheel		

**APPENDIX II
MACHINE RATINGS**

The following rating scale is used in PAMI Evaluation Reports:
 Excellent Very Good
 Good Fair
 Poor Unsatisfactory

**APPENDIX III
CONVERSION TABLE**

1 meter (m)	= 3.3 feet (ft)
1 millimetre (mm)	= 0.04 inches (in)
1 tonne (t) = 1000 kilograms (kg)	= 2204.6 pounds (lb)
1 tonne per hour (t/h)	= 2204.6 pounds per hour (lb/h)
	= 36.74 bushel per hour (bu/h) for 60 lb/bu wheat
	= 45.93 bushel per hour (bu/h) for 48 lb/bu barley
	= 68.84 bushel per hour (bu/h) for 34 lb/bu oats
	= 44.09 bushel per hour (bu/h) for 50 lb/bu canola
1 kilowatt (kW)	= 1.34 horsepower (hp)
1 tonne per kilowatt hour (t/kWh)	= 27.42 bushel per horsepower hour (bu/hph) for 60 lb/bu wheat
	= 34.28 bushel per horsepower hour (bu/hph) for 48 lb/bu barley
	= 48.38 bushel per horsepower hour (bu/hph) for 34 lb/bu oats
	= 32.90 bushel per horsepower hour (bu/hph) for 50 lb/bu canola
1 kilometre/hour (km/h)	= 0.6 miles/hour (mph)

SUMMARY CHART

KONGSKILDE SUC 500 TR2 SUCTION BLOWER

RETAIL PRICE:	\$11,632.00 (June, 1985, f.o.b.Lethbridge)
EASE OF OPERATION AND ADJUSTMENT:	
Intake Nozzle	Good , difficult to maneuver.
Transporting	Very good , easily placed into transport position
Adjustments	
- secondary air setting	Easily adjustable sleeve.
	Convenient automatic air regulator indicator.
RATE OF WORK:	
Maximum Capacity	
- wheat	1370 bu/h (37.2 t/h)
- canola	2460 bu/h (55.8 t/h)
- barley	1740 bu/h (37.9 t/h)
Specific Capacity	
- wheat	0.87 ton/hph (1.06 t/kWh)
- canola	1.24 ton/hph (1.51 t/kWh)
POWER REQUIREMENTS:	
- empty	50 hp (37.5 kw)
- wheat, barley and canola	47 to 49 hp (35 to 36.6 kw)
QUALITY OF WORK:	
- grain damage	Similar to a grain auger in cereal grains, high in dry canola.
OPERATOR SAFETY:	
	Dust free. Ear protection required.
OPERATOR'S MANUAL:	
	Parts list provided - more detailed operating, adjustment and safety information required.



3000 College Drive South
 Lethbridge, Alberta, Canada T1K 1L6
 Telephone: (403) 329-1212
 FAX: (403) 329-5562
<http://www.agric.gov.ab.ca/navigation/engineering/afmrc/index.html>

Prairie Agricultural Machinery Institute

Head Office: P.O. Box 1900, Humboldt, Saskatchewan, Canada S0K 2A0
 Telephone: (306) 682-2555

Test Stations:

P.O. Box 1060
 Portage la Prairie, Manitoba, Canada R1N 3C5
 Telephone: (204) 239-5445
 Fax: (204) 239-7124

P.O. Box 1150
 Humboldt, Saskatchewan, Canada S0K 2A0
 Telephone: (306) 682-5033
 Fax: (306) 682-5080