

# Evaluation Report

# 283



## F.N. Pneumatic Model 2050 Grain Conveyor (Power Take-off Drive)

A Co-operative Program Between



# F.N. PNEUMATIC MODEL 2050 GRAIN CONVEYOR

## MANUFACTURER AND DISTRIBUTOR:

F.N. Pneumatic Manufacturing Ltd.  
101 Fisher Street  
Okotoks, Alberta  
T0J 1T0

## RETAIL PRICE:

(July, 1982, f.o.b. Lethbridge, complete with standard package which includes 6.1 m (20 ft) of 127 mm (5 in) flexible intake pipe, intake nozzle, 3.05 m (10 ft) of flexible discharge pipe and discharge cyclone.)

a. With optional automatic Filter Flushing System (as tested) \$17,900.00

b. With standard manual Filter Flushing System \$14,900.00

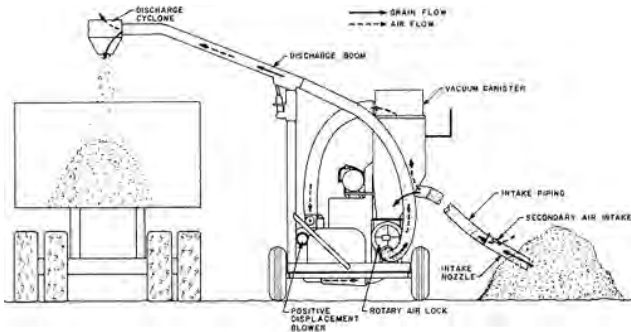

FIGURE 1. Schematic View Showing Air and Grain Flow.

## SUMMARY AND CONCLUSIONS

The functional performance of the F.N. Pneumatic Model 2050 grain conveyor was very good for conveying wheat, barley, oats and canola. Functional performance was lowered by high power consumption.

The maximum conveying rates obtained were 56.0 t/h (2060 bu/h) for wheat, 62.8 t/h (2880 bu/h) for barley, 57.6 t/h (3735 bu/h) for oats and 62.2 t/h (2740 bu/h) for canola. Conveying rates were reduced when intake or discharge pipe lengths were increased.

Power requirements while conveying grain varied from 63.9 to 74.5 kW (86 to 100 hp). A tractor with maximum power takeoff output of at least 80 kW (107 hp) was required due to high starting torques and peak loading requirements.

The specific capacity of an average 178 mm (7 in) diameter grain auger was six times greater than that of the F.N. Pneumatic 2050 in wheat and oats and four and one-half times greater in canola. This indicates that pneumatic conveying of grain is inefficient in terms of power required for the amount of grain moved when compared to a grain auger. However, pneumatic conveyors have advantages a grain auger doesn't have. For example, they are capable of conveying grain over longer distances, both vertically and horizontally, than is possible with a grain auger.

Crackage in dry wheat was less than 0.2% for each pass through the F.N. Pneumatic 2050. This is similar to damage caused by grain augers.

The intake nozzle and flexible hose were fairly easy to maneuver during bin clean-out. The discharge cyclone could be conveniently attached by lowering the discharge boom.

The F.N. Pneumatic was much safer to use than a grain auger, especially for cleaning grain bins. Working near the inlet nozzle was clean as most dust was conveyed into the inlet. It was also safer than an auger since the operator was exposed to fewer moving parts. Noise levels adjacent to the conveyor varied from 96 to 109 dBA when operating in open areas. When operating close to metal bins the noise level was loud and irritating. It is recommended that an operator wear suitable ear protection when working near the F.N. Pneumatic 2050.

Several mechanical failures occurred during the test. The air distributor for the filtering system was replaced because of a bent shaft and two flexible hose couplers pulled apart.

## RECOMMENDATIONS

It is recommended that the manufacturer consider:

1. Modifying the discharge boom so it can be placed into transport position by one man while standing on the ground.
2. Modifications to adequately secure the discharge boom in operating position.
3. Relocating the control valve for the air lock to provide for safer operation.
4. Supplying guidelines for secondary air settings for various grains.
5. Increasing the size of the discharge cyclone to reduce noise and velocity of the grain being discharged.
6. Re-examining the cost benefit of the optional, automatic filter flushing system or consider modifying the flushing system to make filter cleaning more effective.
7. Modifying the connection between the coupler and flexible pipe to prevent failure and unravelling.

Senior Engineer: E. H. Wiens

Project Engineer: R. P. Atkins

Project Technologist: G. A. Magyar

## THE MANUFACTURER STATES THAT

With regard to recommendation number:

1. A handle to swing the discharge boom into transport is standard on all new units.
2. To secure the discharge boom in operating position a heavier bolt and bigger handle has been provided.
3. All new units use tractor hydraulics to drive the airlock and the flow control valve is located next to the airlock. Self contained hydraulic airlock drives are also still available, but on the new models, the blower is turned 180 degrees so the hydraulic pump and control valve are at the back of the machine so the operator doesn't have to reach over the power take-off shaft.
4. Our new operator's manual will include secondary air settings for various grains.
5. The discharge cyclone has been increased in size. A new muffler has also been developed to reduce the noise level.
6. On our self cleaning filter systems, the compressor pressure has been increased for better cleaning of the filter bags. Most of the units are sold with manual filter flushing systems.
7. We now use a 45 degree steel elbow at the airlock, resulting in a smoother bend and eliminating unravelling.

**NOTE:** This report has been prepared using SI units of measurement. A conversion table is given in APPENDIX III.

## GENERAL DESCRIPTION

The F.N. Pneumatic Model 2050 is a 1000 rpm, power take-off driven grain conveyor, mounted on a two wheel trailer. The positive displacement blower (FIGURE 1) provides both suction and discharge air to convey grain without passing it through the blower. Grain is conveyed by the intake airstream through the intake nozzle where it is drawn into the vacuum canister. The grain is then separated from the air and the air is drawn through a filtering system to the blower. The grain passes through the rotary air lock into the discharge airstream of the blower, which delivers it to the discharge cyclone.

Incorporated in the F.N. Pneumatic 2050 filtering system is an optional, automatic flushing unit to clean the eighteen nylon mesh filter bags located in the vacuum canister. The flushing unit consists of a compressor, a storage tank, a distributor and a distribution system. The distributor regulates the amount of air released and which three filter bags are to be flushed at one time.

The blower is driven from the power take-off shaft by 6 V-belts. The rotary airlock is driven by a hydraulic motor. The hydraulic motor is driven by a pump located on the end of the positive displacement blower. The air compressor is V-belt driven off the power take-off shaft.

Intake and discharge locations can be varied by adding sections of rigid and flexible 127 mm (5 in) diameter pipe.

FIGURE 1 shows the location of major components while

detailed specifications are given in APPENDIX I.

## SCOPE OF TEST

The F.N. Pneumatic 2050 was used for 22.5 hours to convey the various grains shown in TABLE 1. It was evaluated for ease of operation and adjustment, rate of work, power requirements, quality of work, operator safety and suitability of the operator's manual.

TABLE 1. Operating Conditions

Material	Quantity Conveyed (t)	Hours
Spring Wheat	245	10.4
Durum Wheat	41	2.0
Barley	216	8.0
Oats	15	0.8
Canola	21	1.3
TOTAL	538	22.5

## RESULTS AND DISCUSSION

### EASE OF OPERATION AND ADJUSTMENT

**Standard Discharge:** The standard discharge assembly (FIGURE 2) consisted of one 3.05 m (10 ft) section of 127 mm (5 in) double wall flexible galvanized steel pipe. This, in turn, was attached to a swing boom to which the discharge cyclone was attached. The swing boom was adjustable laterally and vertically with the aid of a hydraulic jack. The 3.5 m (11.5 ft) discharge height and 2.7 m (8.8 ft) reach were insufficient for filling grain bins but easily accommodated all common truck box heights. The 22 kg (48 lb) discharge cyclone was easily attached by one person to the discharge boom when it was lowered to its minimum height of 1.3 m (4.3 ft).

The discharge boom was also used to lift the top off the vacuum canister to service the filtering system.

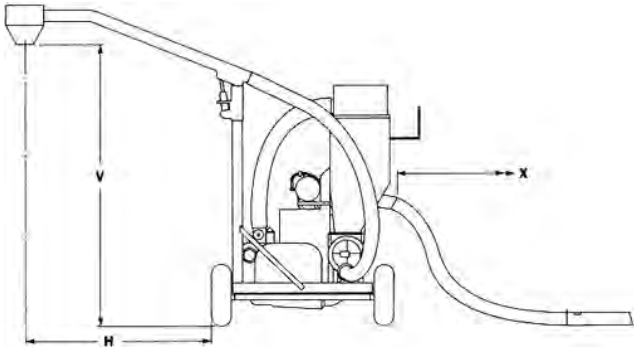

FIGURE 2. Standard Discharge Assembly (V = 3.5 m, H = 2.7 m).

**Conveying Pipes:** Rigid steel pipe sections were available in 3.05 m (10 ft) and 6.1 m (20 ft) lengths while 3.05 m (10 ft) lengths of flexible steel pipe were available to vary inlet and discharge distances. Adjacent pipes were easily joined using quick couplers. The mating surfaces were machined and no gaskets were required for air tight joints.

**Intake Nozzle:** Only one type of intake nozzle was available. The round light weight aluminium nozzle (FIGURE 3) was used for normal grain conveying as well as bin clean-out. A flexible pipe handle was available to aid in bin clean-out. The nozzle and flexible pipe were easy to maneuver so that complete clean-out of a bin could be accomplished. A flat nozzle, however, would have resulted in quicker and more complete bin clean-out.

**Filtering System:** Because of close tolerances, positive

displacement blowers require a complete filtering of the conveying air after it has been separated from the grain in the separator cyclone and before it enters the blower. To prevent dust and finely cracked grain from entering the blower, the upper portion of the vacuum canister was equipped with eighteen, 120 mm (4.7 in) diameter nylon mesh filters (FIGURE 4). The filters were very effective in preventing particles from going through the blower.



FIGURE 3. Intake Nozzle: (A) Adjustable Slide.



FIGURE 4. Air Filters.

The F.N. Pneumatic 2050 was equipped with an optional, automatic flushing system which provided periodic bursts of air to the inside of each filter to blow off accumulated dust. The flushing system did not effectively remove dust from the filters. A 5 to 10 mm (0.2 to 0.4 in) layer of dust accumulated on each filter (FIGURE 5) after 3 hours of operation. A thorough cleaning of the filters required removing the top of the canister with the discharge boom and then blowing, vacuuming or washing the individual filter bags. It took about two hours to remove and thoroughly clean the filtering system. It is recommended that the manufacturer re-examine the cost benefit of the optional automatic filter flushing system or consider modifying the flushing system to make filter cleaning more effective.

Care should be exercised if the F.N. Pneumatic 2050 is used for conveying treated grain. Contamination of other grains could occur if the filter bags were not thoroughly cleaned following use in treated grain.



FIGURE 5. Dust Accumulation on Filters.

**Transporting:** It was difficult for one person to swing the

discharge boom into transport position. To swing the boom into transport, it was necessary to stand on either the blower or shielding over the main drive. The flexible discharge pipe did not have to be disconnected, but it was stiff and heavy, making it difficult to swing the boom into place. Brackets were provided for convenient storage of the flexible intake pipe and nozzle (FIGURE 6). Two men could prepare the conveyor for transport in about two minutes. It is recommended that the manufacturer consider modifications so the boom can be swung into transport position by one person while standing on the ground.



FIGURE 6. Transport Position.

During operation, vibration caused the setscrew provided to secure the boom in the desired position, to loosen. It is recommended that the manufacturer consider modifications to adequately secure the boom in field position.

The F.N. 2050 was very compact and stable in transport position and could be safely towed at speeds up to 60 km/h (38 mph). The 107 mm (4.2 in) ground clearance necessitated caution when transporting over rough ground.

**Hitching:** The F.N. Pneumatic 2050 was easily hitched to tractors with a 1000 rpm power take-off. The hitch jack was convenient. The hitch clevis was not adjustable to suit varying tractor drawbar heights. Consequently, the conveyor could not be adjusted to operate level with all tractors used.

**Adjustments:** All belt drives were easily adjusted and aligned. Belts had to be tightened according to the manufacturer's specifications to ensure proper pulley speeds and belt life.

The speed of the rotary air lock could be conveniently adjusted from 0 to 77 rpm with the needle valve (FIGURE 7). Readjustment was often necessary because the valve would creep. Adjusting the valve presented a hazard to the operator since it was necessary to reach across the power take-off shaft. It is recommended that the manufacturer relocate the control valve to provide for safer operation.

Secondary air flow into the intake nozzle could be easily varied with the adjustable slide provided (FIGURE 3).



FIGURE 7. Flow Control Valve.

**Servicing:** The F.N. Pneumatic had 8 grease fittings and could be serviced in about 10 minutes. Oil levels in the blower gearbox, the distributor, the air compressor and the hydraulic motor reservoir all had to be checked periodically. It was difficult to service the air compressor and several of the grease fittings due to the location of guards and shields.

## RATE OF WORK

**Maximum Conveying Rates:** Conveying rates for the F.N. Pneumatic 2050 depended on the type of grain being conveyed, speed of the rotary air lock, the secondary air setting and the length of intake and discharge pipe.

The conveying rate was very dependent on maintaining a steady flow rate. Highest conveying rates were obtained when the intake nozzle was completely submerged in grain, using one length of flexible intake pipe and the standard discharge assembly (FIGURE 2). As shown in TABLE 2 the maximum conveying rates were 56.0 t/h (2050 bu/h) in wheat, 57.6 t/h (3735 bu/h) in oats, 62.2 t/h (2740 bu/h) in canola and 62.8 t/h (2880 bu/h) in barley. The wide range of conveying rates in TABLE 2 indicates the difficulty in adjusting the intake nozzle air opening and rotary air lock speed to obtain maximum conveying rates.

TABLE 2. Conveying Rates at 1000 rpm Power Take-off Speed

Grain	Intake Pipe Length (X)			Discharge Pipe Length (Y)	
	3.05 m	15.2 m	30.5 m	15.2 m	30.5 m
Wheat	37.3 to 56.0 t/h	30.5 to 35.8 t/h	19.8 to 22.2 t/h	25.1 to 39.5 t/h	19.9 to 34.4 t/h
Barley	46.7 to 62.8 t/h		23.3 to 26.5 t/h		34.3 to 39.2 t/h
Oats	38.6 to 57.6 t/h		28.2 to 32.3 t/h		13.2 to 31.6 t/h
Canola	57.6 to 62.2 t/h		21.0 to 24.2 t/h		28.2 to 32.7 t/h

**Secondary Air Setting:** The amount of secondary air introduced at the intake nozzle was important in obtaining maximum conveying rates. Too little secondary air caused the conveyor to surge. Too much secondary air resulted in inefficient conveying due to reduced suction at the intake. The secondary air setting depended on the density of the material being conveyed and length of conveying pipe. Optimum secondary air settings had to be established by trial and error for each grain conveyed. For example, the optimum setting for wheat, using the standard intake and discharge assembly was determined to be 6.5 mm (FIGURE 8), which resulted in a conveying rate of 56.0 t/h (2060 bu/h). It is recommended that the manufacturer provide similar guidelines for secondary air settings for all grains.

**Air Lock Speed:** Too slow an air lock speed resulted in the vacuum canister plugging. Too fast an air lock speed reduced capacity and could also cause vacuum canister plugging due to improper feeding of the air lock. As recommended by the manufacturer, optimum air lock speed for each grain was obtained by adjusting air lock speed until grain starts to build up in the canister and then open

the valve a quarter turn.

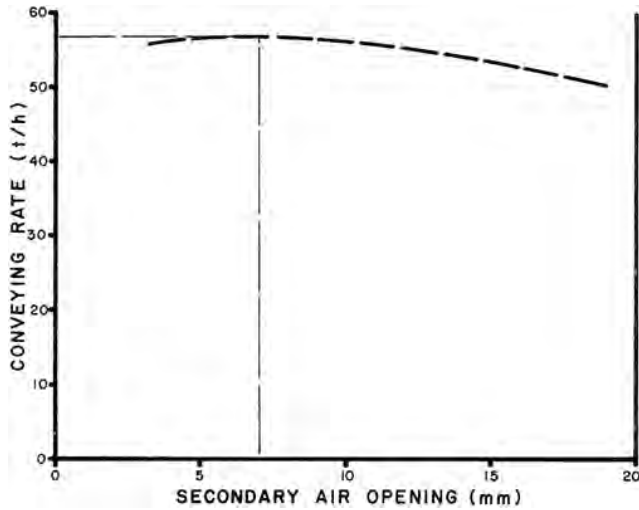

FIGURE 8. Conveying Rates in Wheat for Various Secondary Air Openings.

**Discharge Cyclone:** When operating at less than one-third capacity, the air and grain left the discharge cyclone at high velocities. If the truck was nearly loaded, velocities were high enough to blow grain off the top of the load. It is recommended that the manufacturer consider increasing the size of the discharge cyclone to reduce the velocity of grain being discharged. A larger discharge cyclone would also result in reduced noise levels at the discharge cyclone.

**Effect of Pipe Length:** Conveying rates decreased with increased intake pipe length. For example, increasing the intake pipe length from 3.05 m (10 ft) to 30.5 m (100 ft) (FIGURE 9) reduced the maximum conveying rate from 56.0 to 22.2 t/h (2060 to 816 bu/h) in wheat, from 57.6 to 32.3 t/h (3735 to 2090 bu/h) in oats, from 62.2 to 24.2 t/h (2740 to 1070 bu/h) in canola and from 62.8 to 26.5 t/h (2880 to 1220 bu/h) in barley.



FIGURE 9. Increased Intake Pipe Length.

Increasing the discharge length also reduced the conveying rate. The standard discharge boom had a reach of 2.7 m (8.8 ft). Increasing the discharge length to 30.5 m (100 ft) (FIGURE 10) reduced the conveying capacity in wheat from 56.0 to 34.4 t/h (2060 to 1260 bu/h), in oats from 57.6 to 31.6 t/h (3735 to 2050 bu/h), in canola from 62.2 to 32.7 t/h (2740 to 1440 bu/h) and in barley from 62.8 to 39.2 t/h (2880 to 1800 bu/h).



FIGURE 10. Increased Discharge Pipe Length.

**Filtering System:** The filtering system was very effective in removing dust and fine cracked grain from the air and offered complete protection to the positive displacement blower. However, the optional, automatic flushing system was not completely effective and a layer of dust was allowed to accumulate on the filter bags. Capacity trials showed that dirty filters reduced capacity rates by as much as 14%.

**Comparison to a Grain Auger:** TABLE 3 compares the performance of the F.N. Pneumatic 2050 to that of an average 178 mm (7 in) diameter, 12.5 m (41 ft) long grain auger, at 30° inclination with a lift of 6.4 m (21 ft). Data for the F.N. Pneumatic 2050 was obtained with the standard discharge at a 3.5 m (11.5 ft) lift and 3.05 m (10 ft) of 127 mm (5 in) diameter flexible intake pipe. The maximum conveying rate of the F.N. Pneumatic was 37% greater than the grain auger in spring wheat, 104% greater than the grain auger in oats and 58% greater than the grain auger in canola.

TABLE 3. Comparison of the F.N. Pneumatic to an Average 178 mm Diameter Grain Auger.<sup>1</sup>

Grain Type	Maximum Conveying Rates (t/h)		Specific Capacities/Meter Vertical Lift (tkWh)	
	F.N. Pneumatic	Grain Auger	F.N. Pneumatic	Grain Auger
Wheat	56.0	41.0	0.21	1.25
Oats	57.6	28.2	0.25	1.53
Canola	62.2	39.4	0.23	1.03

Specific capacity can be used to compare the conveying efficiency of the two methods of grain handling. A high specific capacity indicates efficient energy use while a low specific capacity indicates inefficient conveying. The specific capacity per meter of vertical lift for the grain auger was six times greater than that of the F.N. Pneumatic in wheat and oats, and four and one-half times greater in canola. This indicates that pneumatic conveying is inefficient as compared to a grain auger. However, pneumatic conveyors have advantages that grain augers do not have. They are capable of conveying grain over longer distances, both vertically and horizontally, than is possible with a grain auger. Pneumatic conveyors are also safer to operate than grain augers.

**POWER REQUIREMENTS**

FIGURE 11 shows that the maximum power take-off input was 74.5 kW (100 hp) when the F.N. Pneumatic was operating at maximum capacity in wheat. This compared to a power requirement of 30.1 kW (40 hp) when moving air only with the positive displacement blower equipped F.N. Pneumatic. Power input depended on the type of material being conveyed. The heavier the material, the more resistance to flow the material had and the greater the power input required. At maximum conveying rates, power requirements were 74.5, 74.2, 64.2 and 63.9 kW (100, 99, 86 and 86 hp) for wheat, canola, barley and oats, respectively.

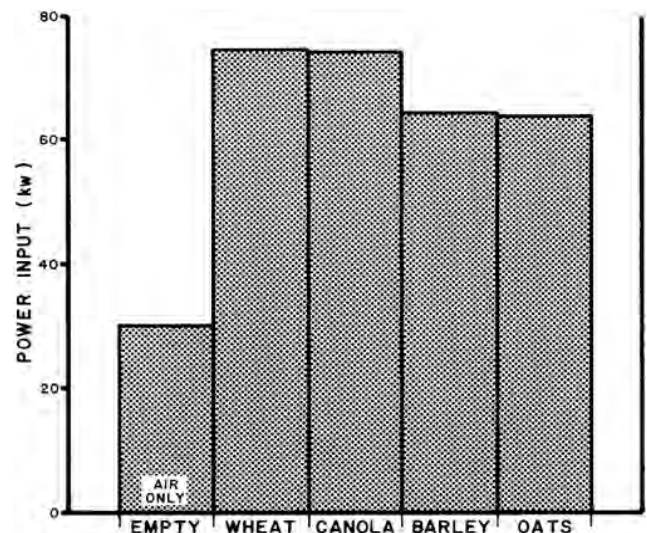

FIGURE 11. Power Requirements at Maximum Conveying Rates.

<sup>1</sup>Grain auger data represents average data results from Machinery Institute test reports 89, 90 and 92.

A minimum tractor size of 80 kW (107 hp) was required for the F.N. Pneumatic 2050 to overcome high starting torques and peak requirements during overloading.

### QUALITY OF WORK

**Grain Damage:** FIGURE 12 shows the increase in grain crackage each time a sample of dry wheat (11.3% moisture content) was conveyed. In these tests the F.N. Pneumatic 2050 was equipped with the standard discharge assembly (FIGURE 2) and a 3.05 m (10 ft) flexible intake pipe. The wheat initially contained 3.6% cracks. Each pass through the F.N. Pneumatic 2050 caused an average of 0.2% increase in crackage. This indicates that if the number of passes is kept to a minimum, grain damage should not be a problem. Test results from grain augers in dry wheat<sup>1</sup> have shown that each pass through an auger causes about 0.2% crackage.

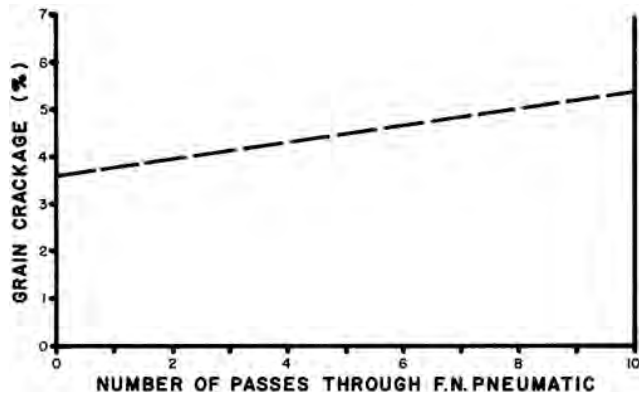

FIGURE 12. Grain Crackage in Dry Wheat.

**Plugging:** Plugging was not a problem when using the standard discharge and 3.05 m (10 ft) of intake pipe, providing the tractor had enough power. Plugging did occur when using longer lengths of intake and discharge pipe because of insufficient air entering the inlet to carry the material being conveyed. Unplugging required discontinuing grain intake and allowing air to clear the blockage. The F.N. Pneumatic 2050 was equipped with a pressure and vacuum relief valve to prevent damage to the blower and drive train (FIGURE 13).

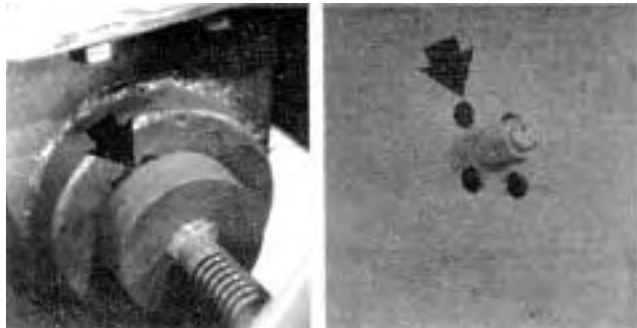

FIGURE 13. Relief Valves (Left: Pressure Relief Valve, Right: Vacuum Relief Valve).

### OPERATOR SAFETY

The F.N. Pneumatic 2050 was safe to operate as all rotating parts were well shielded. The intake nozzle was much safer to operate than a grain auger since there was no exposed flighting or rotating parts. Working near the intake nozzle was virtually dust-free since most dust was conveyed into the inlet. Working near the discharge cyclone was, however, extremely dusty.

Peak noise levels<sup>2</sup> near the F.N. Pneumatic 2050 when powered with an 80 kW (107 hp) tractor varied from 96 to 109 dBA when operating on flat open fields. Noise levels when operating near metal bins and enclosed areas, became very loud and irritating. The noise level was also very high when working near the discharge cyclone, especially when operating at or near empty. It is recommended that an operator wear ear protection when working near the F.N. Pneumatic 2050. It has already been recommended

that the manufacturer consider redesigning the discharge cyclone to reduce noise levels.

The F.N. Pneumatic 2050 was low enough in transport position to pass safely under power lines. Its 2.7 m (8.9 ft) transport width allowed for safe road transport.

A slow moving vehicle sign and warning decals were provided.

### OPERATOR'S MANUAL

The operator's manual was clearly written and contained useful information on operation, servicing, adjustments and safety. A complete parts list was supplied.

### MECHANICAL PROBLEMS

TABLE 4 outlines the mechanical history of the F.N. Pneumatic 2050 during 22.5 hours of operation. The intent of the test was functional evaluation. The following failures represent those, which occurred during functional testing. An extended durability evaluation was not conducted.

TABLE 4. Mechanical History

Item	Operating Hours
<b>Flushing Unit Distributor</b> -A main shaft within the distributor failed and the entire distributor was replaced at	9
<b>Pipe Couplers</b> -The flexible pipe pulled away from the coupler and was repaired at	12, end of test

### DISCUSSION OF MECHANICAL PROBLEMS

**Flushing Unit Distributor:** A shaft within the distributor was bent and the keyway was worn (FIGURE 14). The manufacturer replaced the entire distributor and no further problems occurred for the duration of the test.

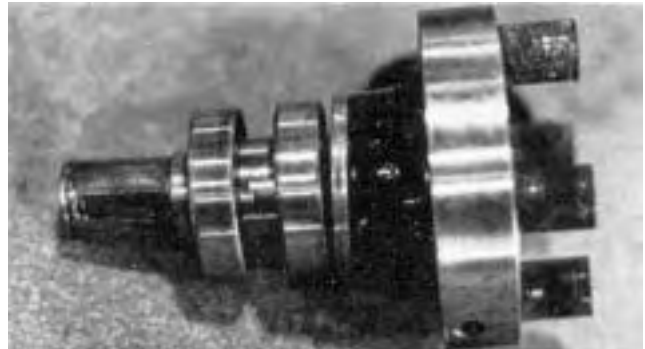

FIGURE 14. Bent Shaft and Worn Keyway in Flushing Unit Distributor.

**Couplers:** On two occasions the flexible pipe pulled away from the four carriage bolts fastening it to the coupler (FIGURE 15) and started to unravel. It is recommended that the manufacturer consider modifying the connection between the coupler and flexible pipe to prevent failure and unravelling.



FIGURE 15. Coupler Failure.

<sup>2</sup>PAMI T791, "Detailed Test Procedures for Determination of Noise Levels from Stationary Processing Equipment".

**APPENDIX I  
SPECIFICATIONS**

**MAKE:** F.N. Pneumatic Grain Conveyor  
**MODEL:** 2050  
**SERIAL NUMBER:** S81 204  
**MANUFACTURER:** F.N. Pneumatic  
 Box 85  
 Carseland, Alberta  
 TOJ 0M0

<b>DIMENSIONS:</b>	<u>Field Position</u>	<u>Transport Position</u>
-- overall length	2900 mm	1900 mm
-- overall height	4690 mm	2130 mm
-- overall width	3960 mm	2710 mm
-- wheel tread	1700 mm	1700 mm

**INTAKE AND DISCHARGE PIPES:** 127 mm diameter

	<u>Length</u>	<u>Weight</u>
<b>FLEXIBLE PIPE:</b>	3050 mm	15 kg
<b>RIGID PIPE:</b>	3050 mm	18 kg
	6096 mm	35 kg

**ROUND NOZZLE:** 4.7 kg

<b>DISCHARGE HEIGHT:</b>	<u>Maximum</u>	<u>Minimum</u>
	3545 mm	1290 mm

**REACH:** 2660 mm

**NUMBER OF LUBRICATION POINTS:** 8 grease fittings, 10 hour service  
 2 wheel bearings, annual service  
 1 gear box, 100 hour service  
 1 flushing unit distributor, 50 hour service  
 1 compressor, 50 hour service  
 1 hydraulic system, 50 hour service

**DRIVES:**

- power take-off 1000 rpm
- blower drive 6 V-belts
- air lock and distributor hydraulic motor
- hydraulic pump direct off blower shaft
- air compressor V-belt

**DISCHARGE CYCLONE:**  
 -- weight 22 kg

**TIRES:** 2, tubeless radial, FR 78-15

<b>WEIGHT:</b>	<u>Field Position</u>	<u>Transport Position</u>
-- right wheel	437 kg	523 kg
-- left wheel	439 kg	339 kg
-- hitch	209 kg	223 kg
Total	1085 kg	1085 kg

<b>CENTRE OF GRAVITY:</b>	<u>Field Position</u>	<u>Transport Position</u>
-- above ground	1525 mm	1428 mm
-- forward of trailer axle	320 mm	349 mm
-- in from left wheel	849 mm	995 mm

**OPTIONAL EQUIPMENT:**  
 -- 6.1 m length of 127 mm rigid pipe\*  
 -- 3 m length of 127 mm rigid pipe\*  
 \*supplied on test machine

**APPENDIX II  
MACHINE RATINGS**

The following rating scale is used in PAMI Evaluation Reports:

(a) excellent	(d) fair
(b) very good	(e) poor
(c) good	(f) unsatisfactory

**APPENDIX III  
CONVERSION TABLE**

1 meter (m)	= 3.3 feet (ft)
1 millimetre (mm)	= 0.04 inches (in)
1 tonne (t) = 1000 kilograms (kg)	= 2204.6 pounds (lb)
1 tonne per hour (t/h)	= 2204.6 pounds per hour (lb/h)
	= 36.74 bushel per hour (bu/h) for 60 lb/bu wheat
	= 45.93 bushel per hour (bu/h) for 48 lb/bu barley
	= 64.84 bushel per hour (bu/h) for 34 lb/bu oats
	= 44.09 bushel per hour (bu/h) for 50 lb/bu canola
1 kilowatt (kW)	= 1.34 horsepower (hp)
1 tonne per kilowatt hour (t/kWh)	= 27.42 bushel per horsepower hour (bu/hph) for 60 lb/bu wheat
	= 34.28 bushel per horsepower hour (bu/hph) for 48 lb/bu barley
	= 48.38 bushel per horsepower hour (bu/hph) for 34 lb/bu oats
	= 32.90 bushel per horsepower hour (bu/hph) for 50 lb/bu canola
1 kilometre/hour (km/h)	= 0.6 miles/hour (mph)



**ALBERTA  
FARM  
MACHINERY  
RESEARCH  
CENTRE**

3000 College Drive South  
 Lethbridge, Alberta, Canada T1K 1L6  
 Telephone: (403) 329-1212  
 FAX: (403) 329-5562  
<http://www.agric.gov.ab.ca/navigation/engineering/afmrc/index.html>

**Prairie Agricultural Machinery Institute**

Head Office: P.O. Box 1900, Humboldt, Saskatchewan, Canada S0K 2A0  
 Telephone: (306) 682-2555

Test Stations:  
 P.O. Box 1060  
 Portage la Prairie, Manitoba, Canada R1N 3C5  
 Telephone: (204) 239-5445  
 Fax: (204) 239-7124

P.O. Box 1150  
 Humboldt, Saskatchewan, Canada S0K 2A0  
 Telephone: (306) 682-5033  
 Fax: (306) 682-5080