

Evaluation Report

324

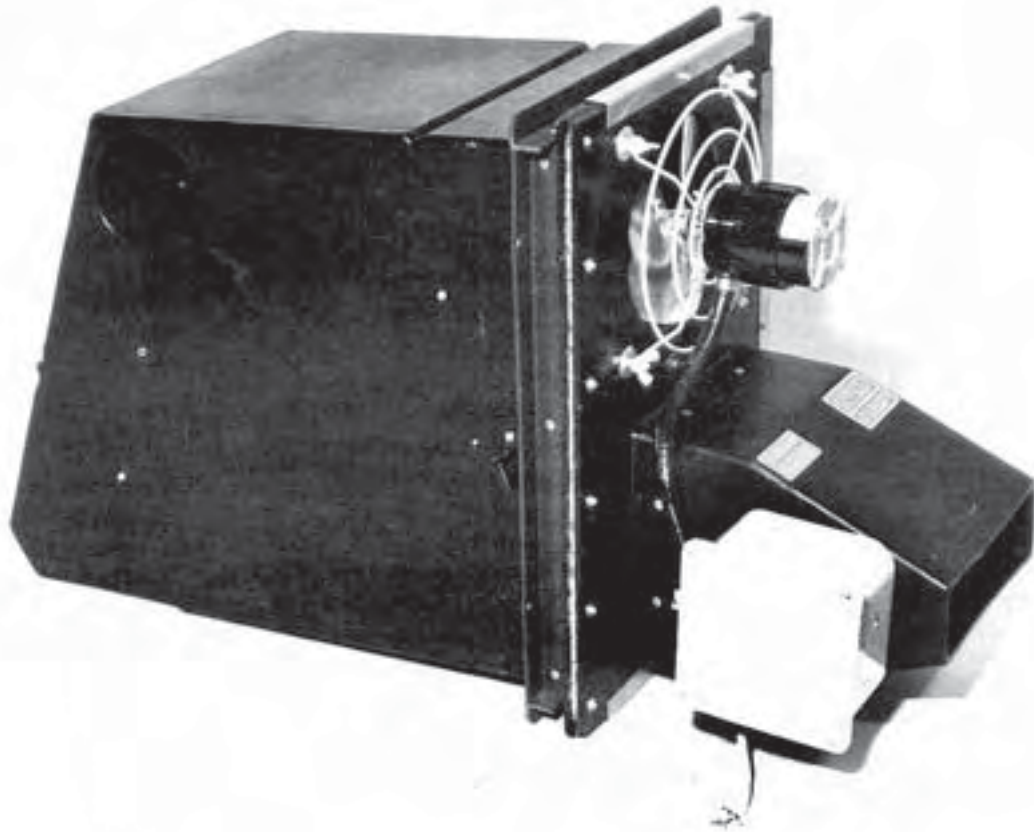

Del-Air A350 Heat Exchanger

A Co-operative Program Between



DEL-AIR A350 HEAT EXCHANGER

MANUFACTURER:

Del-Air Systems Ltd.
P.O. Box 2500
Humboldt, Saskatchewan
S0K 2A0

DISTRIBUTORS:

Feed-Rite Ltd.
17 Speers Road
Winnipeg, Manitoba
R2J 1M1

Besteman Sales Agency
Sub P.O. 24
Saskatoon, Saskatchewan
S7M 0V0

Del-Air Distributors Ltd.
5615 - 103rd Street
Edmonton, Alberta
T6H 2H3

RETAIL PRICE:

\$1295.00 (August, 1983, f.o.b. Humboldt).

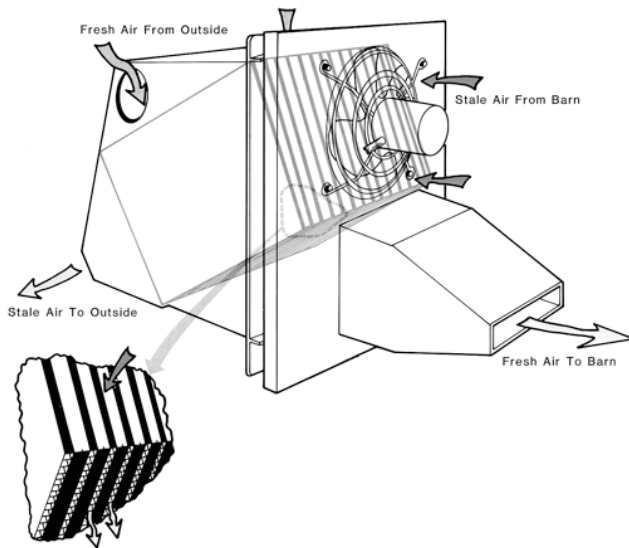

FIGURE 1. Del-Air A350 Heat Exchanger.

SUMMARY AND CONCLUSIONS

Functional Performances: Overall functional performance of the Del-Air A350 heat exchanger was very good.

Fan Performance: Standard airflow while operating at the manufacturer's recommended settings was 385 cfm (182 L/s) exhaust and 298 cfm (141 L/s) supply in the normal mode, and 612 cfm (289 L/s) exhaust in the defrost mode.

Heat Recovery: At Machinery Institute standard test conditions of 65°F (18°C) barn air temperature and 70% relative humidity, the average heat recovered by the Del-Air A350 varied with outside temperature as follows: 15,900 Btu/h (4.7 kW) at -22°F (-33°C), 11,400 Btu/h (3.3 kW) at +5°F (-15°C), and 6000 Btu/h (1.8 kW) at +32°F (0°C). The heat recovery ratio¹ (the percentage of heat recovered from the exhaust air removed from the barn) at the above three outside temperatures was 41%, 42% and 41% respectively.

Leakage: During the Machinery Institute leakage test, 25 cfm (12 L/s) or 6% of the normal exhaust airflow leaked into the supply air passages.

Ease of Operation and Adjustment: Ease of installation

¹The heat recovery ratio is not the same as effectiveness. The Machinery Institute recommends that the heat recovery ratio be used rather than effectiveness to compare the heat recovery performance of different heat exchangers.

was very good. In the moderately dusty environment of a grower/finisher hog barn, the core of the Del-Air A350 required washing once every 3 or 4 weeks. Ease of cleaning was very good. The core of the Del-Air A350 did not freeze up during the tests. Water condensing in the core of the Del-Air A350 drained outside the barn. During midwinter months, a large pile of ice formed beneath the heat exchanger and had to be removed weekly.

Power Requirements: The Del-Air A350 drew a maximum current of 2.12 A when plugged into a standard 120 V, 3 pin outlet. Average power required was 240 W.

Safety: The Del-Air A350 was safe to operate as long as the manufacturer's safety instructions were followed.

Operator Manual: The operator manual was clearly written, contained much useful information, but was poorly illustrated.

Mechanical History: No mechanical problems occurred during the tests.

RECOMMENDATIONS

It is recommended that the manufacturer consider:

1. Lengthening the electrical cord to provide greater flexibility in positioning the heat exchanger.
2. Revising the operator manual to indicate that washing the core through the exhaust air inlet is ineffective.
3. Including more photographs or illustrations in the operator manual, especially for installation and maintenance.

Senior Engineer: G. E. Frehlich

Project Engineer: J. C. Begin

Project Technologist: M. W. Garrod

THE MANUFACTURER STATES THAT

With regard to recommendation number:

1. To be certified to meet the requirements of the Canadian Electrical Code, the Canadian Standards Association requires that the electrical cord not exceed 3 ft (1.4 m) in length.
2. All of our agricultural heat exchangers now have a hinged front face, which opens for full access to the core when cleaning. Reference to cleaning the unit through the exhaust air inlet has been deleted from the operator manual.
3. The operator manual is currently being revised. When completed, it will be better organized and will include more pictures.

GENERAL DESCRIPTION

The Del-Air A350 (FIGURE 1) is a cross-flow air-to-air heat exchanger, designed to recover waste heat from ventilation air in livestock buildings. It consists of a moulded plastic shell enclosing a plastic core and supporting two axial fans and two air distribution nozzles. The heat exchanger core is constructed from corrugated plastic sheets separated by narrow spacers and cemented together with resinous epoxy.

During normal operation, the exhaust fan draws stale barn air into the exhaust passages of the core, and forces it outside through a nozzle. The supply fan draws fresh outside air into the supply passages of the core and forces it through a nozzle into the barn. The stale exhaust air does not mix with the fresh supply air in the core. However, heat from the exhaust air is transferred through the passage walls to the supply air.

During defrost operation, the supply fan is reversed and exhaust air is blown through both the supply and exhaust passages to melt ice that may have built up in the exhaust passages. The heat exchanger is automatically switched into defrost once every hour for 8 minutes. The Del-Air A350 is designed for operation on a 120 V AC outlet.

Detailed specifications are given in APPENDIX I.

SCOPE OF TEST

The Del-Air A350 was operated in a grower/finisher hog barn in the conditions shown in TABLE 1 for 143 days during the winter of 1982-83. During this time, it was evaluated² for ease of operation and adjustment, safety, and suitability of the operator manual. In

addition, the Del-Air A350 was tested in the laboratory to determine fan performance, heat recovery, power requirements and leakage.

TABLE 1. Operating Conditions.

Type of barn:	grower/finisher hog barn
Number of animals:	400
Construction:	wood frame
Insulation levels:	walls R20; ceiling R32
Layout:	centre manure pit with outside feed alleys, 32% slatted floor overhead auger to self feeders
Feeding system:	overhead auger to self feeders
Feed type:	pelletized
Frequency of feeding:	twice per day
Average barn temperature:	69°F (21°C)
Average barn humidity:	65%
Outside temperature:	°F (°C)

	NOV.	DEC.	JAN.	FEB.	MARCH
Monthly Min:	-24 (-31)	-31 (-35)	-38 (-38)	-39 (-40)	-13 (-25)
Mean:	+12 (-11)	+8 (-13)	+7 (-14)	+9 (-13)	+18 (-8)

RESULTS AND DISCUSSION

EASE OF OPERATION AND ADJUSTMENT

Installation: The Del-Air A350 was very easy to install, and took one man two hours. It is designed to mount between 2 studs at 16 in (406 mm) centres (FIGURE 2). Extra materials needed were 7 ft (2.1 m) of weather strip and an 8 ft (2.5 m) length of 2 x 6 in (100 x150 mm) wood. Ducting was not required.

The operator manual indicated that the heat exchanger must be plugged directly into a 110 V outlet without using an extension cord. The 34 in (864 mm) electrical cord was too short to allow flexibility in locating the heat exchanger. It is recommended that the manufacturer lengthen the electrical cord.



FIGURE 2. The Del-Air A350 Installed.

Cleaning: In the moderately dusty environment of a grower/finisher hog barn, the Del-Air A350 had to be washed once every 3 or 4 weeks to remove dirt, which had built up in the exhaust passages.

Washing was very easy and effective. The Del-Air A350 was equipped with a hinged faceplate, which could easily be swung open (FIGURE 3) to provide complete access to the core with a pressure washer (FIGURE 4).



FIGURE 3. Access to the Core.

²Tests were conducted as outlined in the Machinery Institute Detailed Test Procedures for Air-to-Air Heat Exchangers.



FIGURE 4. Washing with a Pressure Washer.

The operator manual indicated that the core could also be washed through the exhaust inlet with the exhaust fan removed. Although washing this way was easier, it did not clean all the dirt from the corners of the core. It is recommended that the operator manual be revised to indicate that washing through the exhaust inlet is not effective.

Condensation and Freeze-Up: Water condensing in the exhaust passages of the Del-Air A350 was drained outside the building through the exhaust outlet nozzle and bottom drainage hole. At outside temperatures below freezing, the condensate formed an ice pile below the exhaust nozzle (FIGURE 5). During midwinter months, the ice had to be chipped away once each week, to prevent it from deforming the nozzle.



FIGURE 5. Outside Ice Formation.

During Machinery Institute standard tests, the Del-Air A350 did not freeze up when operated continuously at an outside temperature of -22°F (-30°C). Under less favourable conditions such as lower exhaust or outside air temperatures, or lower exhaust air humidity, the heat exchanger core may freeze up. The operator manual listed recommended operating conditions to prevent freeze-up.

FAN PERFORMANCE

The performance³ of the Del-Air A350 exhaust and supply fans for a typical installation⁴ is shown in FIGURE 6. The flow of standard air at the manufacturer's recommended operating static pressure of -0.10 in-wg (inches water gage) (-25 Pa) was 385 cfm (182 L/s) exhaust and 298 cfm (141 L/s) supply. The exhaust flow during defrost with both fans exhausting air was 612 cfm (289 L/s).

HEAT RECOVERY

Standard Test Conditions: The amount of heat recovered by a heat exchanger depends on many factors, including the design of the heat exchanger; the supply and exhaust air temperatures; the barn relative humidity; the method of defrost used; and the amount of dirt, water and ice in the heat exchanger core. Therefore, to compare

³Fan performance is given for standard air at a temperature of 59°F (15°C) and a barometric pressure of 29.9 in Hg (101.3 kPa) at sea level.

⁴Typical Installation: Since the Del-Air A350 does not use additional ducts for air distribution, airflow through the heat exchanger depends mostly on the barn static pressure (difference between inside and outside static pressures).

TABLE 2. Heat Recovery Test Results at Standard Conditions.**

STANDARD TEST CONDITIONS										
	Units	1	2	3	4	5	6	7	8	9
Barn Air Temperature (70% Relative Humidity)	°F °C	75 24	65 18	50 10	75 24	65 18	50 10	75 24	65 18	50 10
Outside Air Temperature	°F °C	-22 -30	-22 -30	-22 -30	+5 -15	+5 -15	+5 -15	+32 0	+32 0	+32 0
Temperature of Air Entering Barn	°F °C	41 8	35 2	31 -1	52 11	46 8	40 4	59 16	54 12	47 8
Exhaust Airflow	cfm L/s	400 189	400 189	400 189	400 189	400 189	400 189	400 189	400 189	400 189
Supply Airflow	cfm L/s	610 146	310 146	310 145	310 146	310 146	310 146	310 146	310 146	310 146
Exhaust Heat Loss	Btu/h kW	41800 12.3	38500 11.3	32300 9.5	30800 9.0	26800 7.9	20700 6.1	18700 5.5	14600 4.3	8200 2.4
Average Heat Recovery	Btu/h kW	17300 5.1	15900 4.7	14400 4.2	12900 3.8	11400 3.3	9600 2.9	7300 2.1	6000 1.8	4100 1.2
Heat Recovery Ratio*	%	41	41	45	42	42	47	39	41	50

*The heat recovery ratio is not the same as effectiveness, The Machinery Institute recommends that the heat recovery ratio be used rather than effectiveness to compare the heat recovery performance of different heat exchangers.

**Barometric Pressure during the tests was: mean = 27.9 in-Hg (94.2 kPa); CV = 0.8%.

the performance of different heat exchangers, they must be tested under the same operating conditions. The Machinery Institute has selected the nine operating conditions listed in TABLE 2 as standard test conditions for heat exchangers.

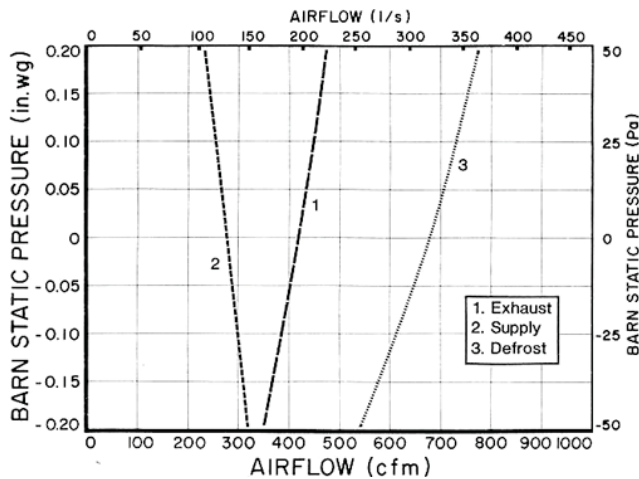

FIGURE 6. Heat Exchanger Airflow.

Average Heat Recovery: This is the average rate at which sensible heat is recovered from the exhaust air at each standard test condition. It takes into consideration the defrost operation, during which no heat is recovered because air is exhausted by both the supply and exhaust fans.

The average heat recovery gives a true indication of how much heat can be recovered by a heat exchanger at each standard test condition. It should not be used to compare the performance of different heat exchangers unless they have the same exhaust airflow.

The average heat recovery of the Del-Air A350 varied from 4100 Btu/h (1.2 kW) to 17,300 Btu/h (5.1 kW) as shown in TABLE 2 and in FIGURE 7.

Heat Recovery Ratio: When air is exhausted from a barn, it is cooled to the outside air temperature. The sensible heat lost by this air as it is cooled, is referred to as the exhaust heat loss. When the exhausted air passes through a heat exchanger, part of this heat is recovered and returned to the barn. It is impossible for a heat exchanger to recover 100% of the exhaust heat loss. However, expressing the average heat recovered as a percentage of the exhaust heat loss gives a good indication of heat exchanger performance. This expression is called the heat recovery ratio. The higher the heat recovery ratio, the better is the performance of the heat exchanger.

The heat recovery ratio of the Del-Air A350 varied from 41% to 50% as shown in TABLE 2.

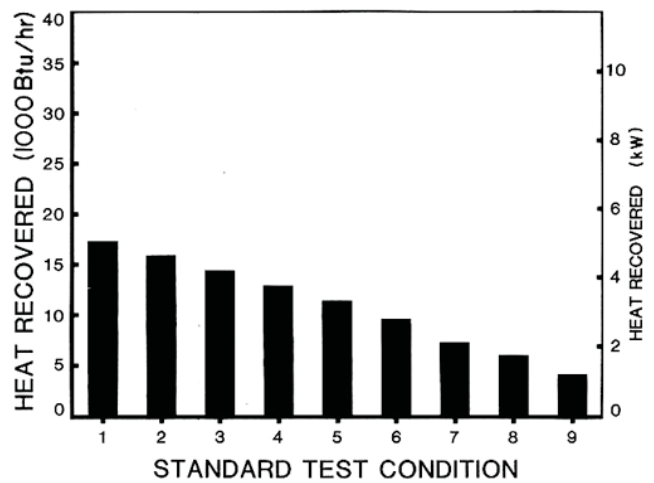

FIGURE 7. Average Heat Recovery of the Del-Air A350.

POWER REQUIREMENTS

The Del-Air A350 drew a maximum current of 2.12 A when plugged into a standard 120 V, 3 pin outlet. Average power required was 240 W.

SAFETY

The Del-Air A350 was safe to operate if the manufacturer's instructions for servicing were followed.

The heat exchanger is CSA (Canadian Standards Association) certified to meet the requirements of the Canadian Electrical Code.

OPERATOR MANUAL

The operator manual consisted of loose-leaf pages without page numbers. Although clearly written, it was poorly illustrated. It is recommended that more photographs be included, particularly in the sections on installation and maintenance.

The manual contained useful information on placement, installation, and maintenance of the heat exchanger. Information included for overcoming core freeze-up was very useful.

The manual indicated that the barn static pressure should be kept below 0.10 in-wg (25 Pa) vacuum. Most farmers do not have the means to measure this.

DURABILITY RESULTS

No electrical or mechanical failures occurred during the 143 days of operation in a grower/finisher hog barn. The intent of the test was to evaluate the functional performance of the machine. An extended durability test was not conducted.

Effectiveness: Effectiveness is one measure of heat exchanger performance often stated in manufacturers' literature. Although useful for design purposes, effectiveness can often be misleading

as an indicator of heat exchanger performance. In particular, when the supply airflow is less than the exhaust airflow, a heat exchanger may have a high effectiveness, but may recover only a small amount of the exhaust heat loss.

In addition, effectiveness is not an average value and does not account for the defrost operation which can vary considerably among heat exchangers. The Machinery Institute therefore recommends that the heat recovery ratio be used, rather than effectiveness, to compare the heat recovery performance of heat exchangers.

LEAKAGE

The amount of air that leaked from the exhaust to the supply airstream during the Machinery Institute leakage test⁶ was 25 cfm (12 L/s). This was 6% of the normal exhaust airflow. The test gives a relative indication of the amount of leakage occurring and may not equal the leakage across the core during normal operation.

APPENDIX I SPECIFICATIONS		
MAKE:	Del-Air	
MODEL:	A350	
SERIAL NO.:	CV1555B	
OVERALL DIMENSIONS:		
-- length	42.8 in (1086 mm)	
-- width	17.8 in (451 mm)	
-- height	25.0 in (635 mm)	
OVERALL WEIGHT:	53.5 lb (24.3 kg)	
CONSTRUCTION MATERIAL:		
-- external shell	polyethylene	
-- internal core	polypropylene	
-- bonding	3M epoxy	
DEFROST SYSTEM:		
-- method	supply fan automatically reversed for 8 minutes every hour	
-- controls	no adjustments	
EXHAUST SUPPLY INLET PORT AREA:	54.5 in ² (0.352 m ²) 39.7 in ² (0.256 m ²)	
OUTLET NOZZLE AREA:	33.6 in ² (0.217 m ²) 26.3 in ² (0.169 m ²)	
FLOW AREA OF CORE (INLET & OUTLET):	98.6 in ² (0.636 m ²) 74.4 in ² (0.480 m ²)	
PASSAGE SIZE:		
-- width	0.13 to 0.31 in (3.3 to 7.9 mm) 0.125 in (3.2 mm)	
-- height	0.21 to 5.25 in (5.3 to 133 mm) 0.20 in (5.2 mm)	
-- length	22.0 in (559 mm) 12.0 in (305 mm)	
FANS:		
-- type	propeller	propeller
-- fan size	8 in (202 mm)	8 in (202 mm)
-- number of blades	5	4
-- blade pitch	26°	32°
-- motor voltage	120 volts	120 volts

APPENDIX II MACHINE RATINGS	
The following rating scale is used in Machinery Institute Evaluation Reports:	
excellent	fair
very good	poor
good	unsatisfactory

APPENDIX IV CONVERSION TABLE		
IMPERIAL UNITS	MULTIPLY BY	SI UNITS
Inches (in)	25.4	Millimetres (mm)
Feet (ft)	0.305	Metres (m)
Pounds Mass (lb)	0.454	Kilograms (kg)
Cubic Feet/Minute (cfm)	0.472	Litres/Second (L/s)
Pounds/Square Inch (psi)	6.89	Kilopascals (kPa)
Inches Mercury (in Hg)	3.39	Kilopascals (kPa)
Inches of Water Gage (in-wg)	0.25	Kilopascals (kPa)
1000 Btu/hour (Btu/h)	0.293	Kilowatts (kW)

APPENDIX V			
HEAT RECOVERY EQUATIONS			
Average Heat Recovery:	$q_r = W_s C_p (t_2 - t_1) f$		
Exhaust Heat Loss:	$q_e = W_e C_p (t_3 - t_1)$		
Heat Recovery Ratio:	$R_q = 100 (q_r/q_e)$		
DEFINITION OF SYMBOLS USED			
Symbol	Description	UNITS Imperial	S.I.
C_p	specific heat of air	Btu/lb°F	kJ/kg°C
f	fraction of time during which heat is recovered		
W_s	mass flow rate of supply air	lb/h	kg/s
W_e	average mass flow rate of exhaust air	lb/h	kg/s
t_1	outside air temperature	°F	°C
t_2	average temperature of fresh air entering barn	°F	°C
t_3	barn air temperature	°F	°C
q_e	exhaust heat loss	Btu/h	kW
q_r	average heat recovery	Btu/h	kW
R_q	heat recovery ratio	%	%

⁶See Machinery Institute Detailed Test Procedures for Air-to-Air Heat Exchangers.

SUMMARY CHART

DEL-AIR A350 HEAT EXCHANGER

RETAIL PRICE: \$1295.00 (August, 1983, f.o.b. Humboldt)

	<u>EVALUATION</u>	<u>COMMENTS</u>
FAN PERFORMANCE		
Airflow in a Typical Installation		
Exhaust	385 cfm (182 L/s)	-- standard air
Supply	298 cfm (141 L/s)	
HEAT RECOVERY		
Average Heat Recovered at Outside		
Temperature of:		
-22°F (-30°C)	15,900 Btu/h (4.7 kW)	-- at exhaust air condition of +65°F (18°C) and 70% relative humidity.
+5°F (-15°C)	11,400 Btu/h (3.3 kW)	
+32°F (0°C)	6,000 Btu/h (1.8 kW)	
Heat Recovery Ratio at Outside		
Temperature of:		
-22°F (-30°C)	41%	-- The heat recovery ratio is not the same as effectiveness. The Machinery Institute recommends that the heat recovery ratio be used rather than effectiveness to compare the heat recovery performance of different heat exchangers.
+5°F (-15°C)	42%	
+32°F (0°C)	41%	
LEAKAGE		
	25 cfm (12 L/s)	
	6% exhaust airflow	
EASE OF OPERATION AND ADJUSTMENT		
Installation	Very Good	-- about 2 hours for 1 man
Cleaning	Very Good	-- effective cleaning with pressure washer
Adjustment	Not Applicable	
POWER REQUIREMENTS		
Voltage	120 V	
Average Power Consumption	240 W	
OPERATOR SAFETY		
	Good	-- CSA approval to Canadian Electrical Code
OPERATOR MANUAL		
	Fair	-- much useful information -- poorly organized and illustrated

CAUTION:

This summary chart is not intended to represent the final conclusions of the evaluation reports. The relevance of the ratings is secondary to the information provided in the full text of the report. It is not recommended that a purchase decision be based only on the summary chart.



3000 College Drive South
Lethbridge, Alberta, Canada T1K 1L6
Telephone: (403) 329-1212
FAX: (403) 329-5562
<http://www.agric.gov.ab.ca/navigation/engineering/afmrc/index.html>

Prairie Agricultural Machinery Institute

Head Office: P.O. Box 1900, Humboldt, Saskatchewan, Canada S0K 2A0
Telephone: (306) 682-2555

Test Stations:

P.O. Box 1060
Portage la Prairie, Manitoba, Canada R1N 3C5
Telephone: (204) 239-5445
Fax: (204) 239-7124

P.O. Box 1150
Humboldt, Saskatchewan, Canada S0K 2A0
Telephone: (306) 682-5033
Fax: (306) 682-5080