

Evaluation Report

500

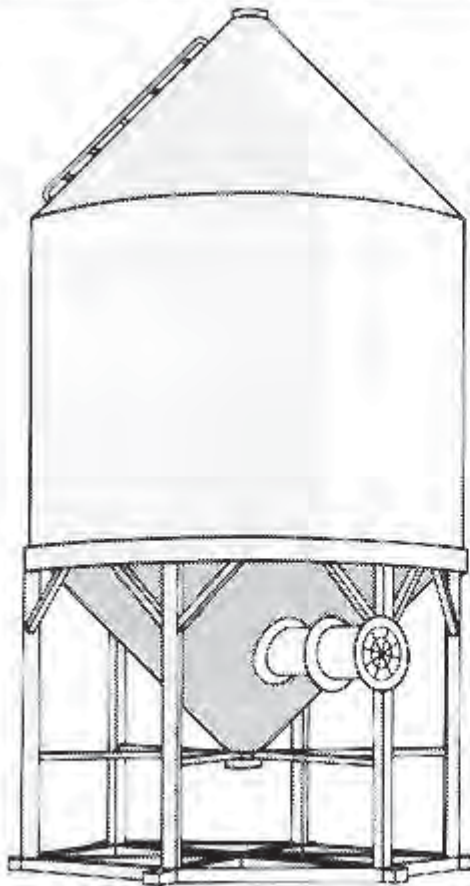

Bader
Grain Guard GG 7000
Keho Diamond
Lode-King High Flow
Trail Rite Mark IV
Weninger Horizontal
Weninger Rocket

Hopper Bottom Bin Natural Air Drying Systems

A Co-operative Program Between



HOPPER BOTTOM BIN NATURAL AIR DRYING SYSTEMS

TERMINOLOGY

DRYING UNIFORMITY

Drying uniformity in a natural air drying system depends on the uniformity of the airflow through the bin. Ideally, the natural air drying system should provide uniform airflow through all parts of the bin. If the air flow is uniform throughout the bin, the top layer of grain through which the air passes will dry all at the same time. If the airflow is not uniform, parts of this top layer of grain will take longer to dry than other parts. While the last part is being dried, the air passing through the top layer that is already dry is being wasted.

Drying uniformity, however, is less important if the operator is "average drying" the grain. When average drying the grain, the wet grain at the top of the bin is mixed with the over dried grain at the bottom of the bin to obtain an average dry grain moisture content. Since the top layer is mixed before it starts to dry, none of the air passing through the grain is wasted.

PAMI rates the drying uniformity of natural air drying systems by comparing them to an ideal system. The time required for all the top layer of grain to dry for the system is compared to the time required for the top layer to dry if airflow was ideal. The smaller the difference between these two times, the better the rating.

As an example, FIGURE 1 compares two distribution systems A and B. The bars on the graph represent the time it took to dry the top layer of grain at various points across the diameter of the bin as shown in the bin diagram below the graph. The high bars represent longer drying times and the line across the graph represents the ideal drying time. From FIGURE 1, it can be seen that system B provides more uniform drying than system A, since the difference between the longest drying time and ideal drying time is less. Therefore, system B would receive a higher rating for drying uniformity.

SYSTEM PRESSURE LOSS

System pressure loss is a measure of how efficiently a natural air drying system directs the air from the fan to the grain. An inefficient drying system will have a high system pressure loss.

The system pressure loss given by PAMI includes the pressure loss as the air passes along the ducts as well as the loss as the air enters the grain.

Assigning an exact pressure loss to a natural air drying system is usually unrealistic, because of the large variations in static pressure that occur with different grain conditions. In this report, only the range of pressure loss that can be expected in wheat is given for each system.

SCOPE OF TEST

Each hopper bin natural air drying system was operated in a hopper bin for about 25 hours. It was evaluated for quality of work, ease of operation, operator safety, and suitability of the operator's manual.

Senior Engineer: G.E. Frehlich
Project Engineer: D.E. Lischynski
Project Technologist: W.F. Stock

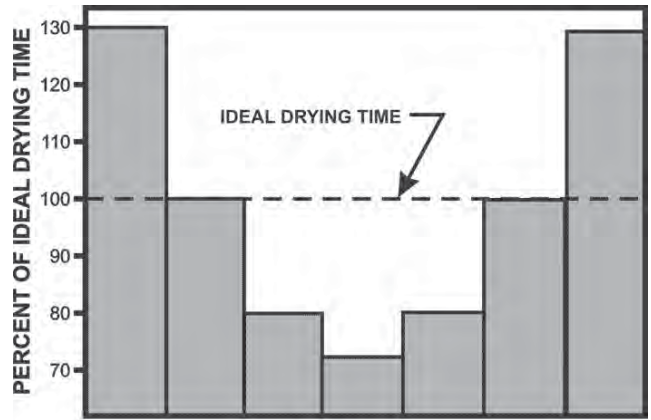

SYSTEM "A"

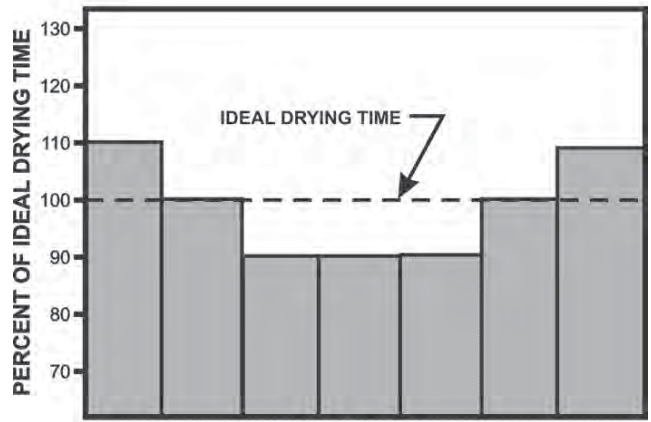

SYSTEM "B"

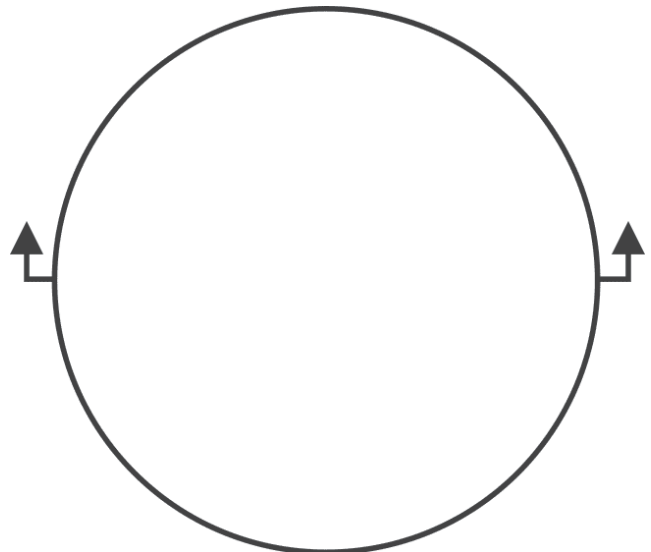

FIGURE 1. Drying Uniformity Example.

Bader

MANUFACTURER AND DISTRIBUTOR:

Gus Bader & Son Agri Products Inc.
 P.O. Box 1614
 Swift Current, Saskatchewan
 S9H 4G5
 1-800-667-7422

SUMMARY AND CONCLUSIONS

Drying uniformity was very good. System pressure loss was 0.5 to 1.5 in wg (125 to 375 Pa) at an airflow of 2000 cfm (940 L/s) in wheat. The natural air drying system could be factory installed only in Bader bins and could not be field installed.

Ease of cleaning the natural air drying system was very good.

No operator's manual was provided and no mechanical problems were encountered. The bin and air distribution system were epoxy coated for storing fertilizer.

RECOMMENDATIONS

It is recommended that the manufacturer consider:

1. Providing natural air drying guidelines with each system.

THE MANUFACTURER STATES THAT:

With regard to recommendation number:

1. Natural air drying guidelines will be provided for future systems.

GENERAL DESCRIPTION

The Bader hopper bin natural air drying system (FIGURE 2) is a factory installed permanent air distribution system. A triangular double wall support at the top of the hopper forms the plenum to direct the air around the circumference of the bin. Thirty-six oval holes in the hopper allow air to enter the bin from the plenum. Triangular ducts of varying lengths are installed over the holes and extend down the hopper to distribute the air to different parts of the bin.

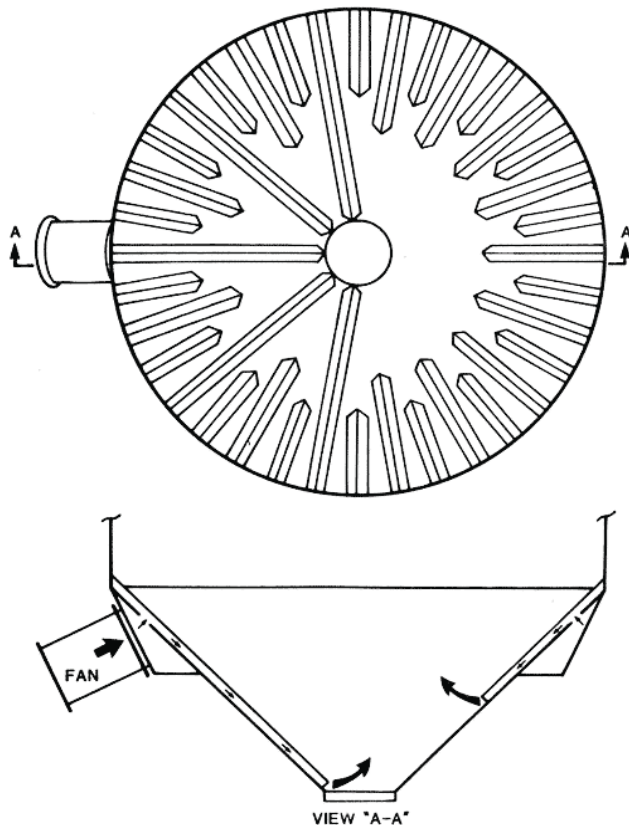

FIGURE 2. Bader Hopper Bin Natural Air Drying System.

RESULTS AND DISCUSSION

QUALITY OF WORK

Drying Uniformity: Drying uniformity with the Bader hopper bin natural air drying system was very good. Airflow was higher at the outside edges of the bin than in the centre of the bin. This resulted in parts of the top layer taking 5 to 15% longer to dry completely than if the air flow uniformity throughout the bin was ideal (FIGURE 3). Drying uniformity was improved by filling and leveling the bin to the eaves.

System Pressure Loss: System pressure loss with the Bader natural air drying system was 0.5 to 1.5 in wg (125 to 375 Pa) when operating with an airflow of 2000 cfm (940 L/s) in wheat. This was within acceptable limits.

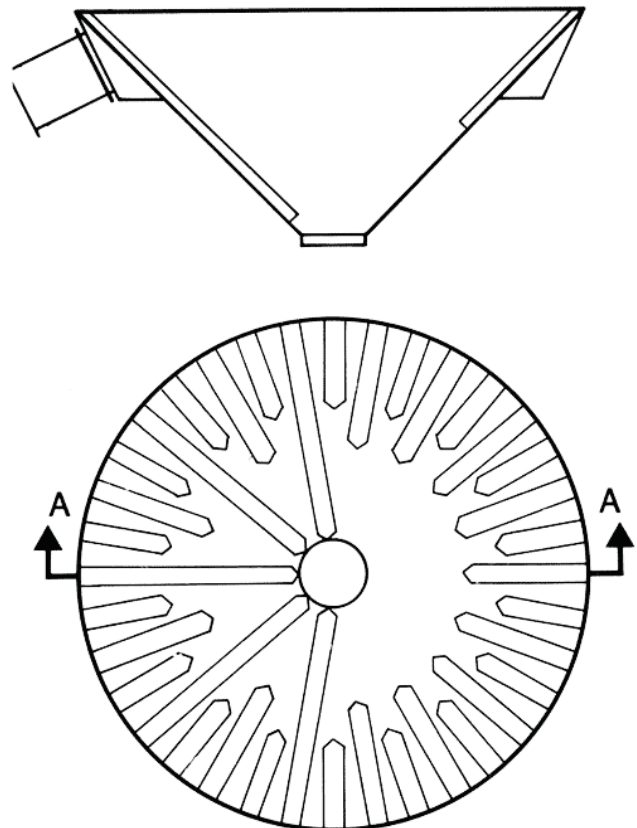
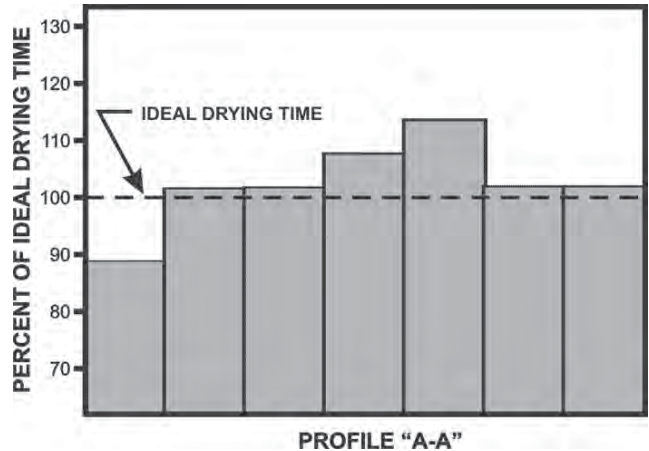

FIGURE 3. Bader Drying Uniformity.

EASE OF INSTALLATION AND OPERATION

Installation: The Bader was permanently factory installed in a Bader 1200E hopper bin. This system can be factory installed in other sizes of Bader bins, but cannot be used in any other makes of bins.

Cleaning: Ease of cleaning the Bader natural air drying system was very good. The ducts did not plug when operating with wheat and did not prevent the bin from emptying completely.

OPERATOR SAFETY

No safety hazards were present when normal precautions were observed.

OPERATOR'S MANUAL

No operator's manual was provided. It is recommended that the manufacturer provide natural air drying guidelines with each system.

MECHANICAL HISTORY

No mechanical problems were encountered during testing. Loading the bin off-centre with wheat did not cause any mechanical damage. The bin and air distribution system were epoxy coated for storing fertilizer. An extended durability test was not performed.

SPECIFICATIONS	
MAKE:	Bader
AIR DISTRIBUTION SYSTEM:	
-- plenum	
-height	18 in (457 mm)
-base width	6 in (152 mm)
-shape	triangular
-- plenum holes	
-shape	oval
-size	5 x 3 in (127 x 76 mm)
-number	36
-air/grain interface area	3.59 ft ² (0.33 m ²)
-- air distribution ducts	
-shape	triangular
-size	7.7 x 5, 3 x 5, 3 in (195 x 135 x 135 mm)
-length	18 at 2.8 ft (0.84 m) 13 at 4.2 ft (1.27 m) 5 at 8.3 ft (2.54 m)
TRANSITION:	
-- inlet size	18 in (457 mm) diameter
-- outlet size	20 x 20 in (508 x 508 mm)
-- length	N/A

Grain Guard GG 7000

MANUFACTURER AND DISTRIBUTOR:

Grain Guard Manufacturing & Sales Ltd
9230 - 27 Avenue
Edmonton, Alberta
T6N 1B2
(403) 462-1172

SUMMARY AND CONCLUSIONS

Drying uniformity was very good. System pressure loss was 0.5 to 1.5 in wg (125 to 375 Pa) at an airflow of 2000 cfm (940L/s) in wheat. The natural air drying system was factory installed by the bin manufacturer and could be field installed in some bins.

Ease of cleaning the natural air drying system was good. No operator's manual was provided and no mechanical problems were encountered. The system could be epoxy coated as an option for storing fertilizer.

RECOMMENDATIONS

It is recommended that the manufacturer consider:

1. Providing natural air drying guidelines with each system.

THE MANUFACTURER STATES THAT:

With regard to recommendation number:

1. Guidelines are always provided when a blower is supplied and will soon be available with each system.

GENERAL DESCRIPTION

The Grain Guard GG 7000 hopper bin natural air drying system

(FIGURE 4) consists of a hollow cylinder positioned vertically at the bottom centre of the bin. Louvered screens on the inside and outside of the cylinder allow air to enter the grain from the cylinder. A rectangular transition enters the side of the hopper to direct air from the fan to the air distribution system.

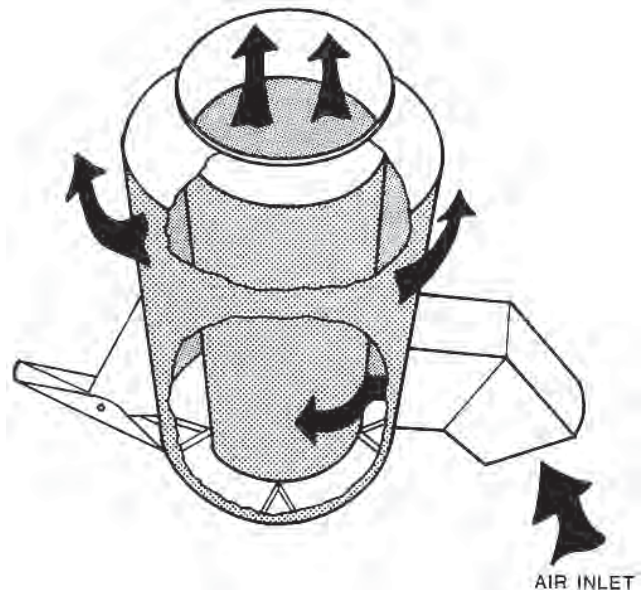

FIGURE 4. Grain Guard GG 7000 Hopper Bin Natural Air Drying System.

RESULTS AND DISCUSSION

QUALITY OF WORK

Drying Uniformity: Drying uniformity with the Grain Guard GG 7000 hopper bin natural air drying system was very good. Airflow was higher in the centre of the bin than at the outside edges of the bin. This resulted in parts of the top layer taking 5 to 15% longer to dry completely than if the airflow uniformity throughout the bin was ideal (FIGURE 5).

System Pressure Loss: System pressure loss with the Grain Guard GG 7000 natural air drying system was 0.5 to 1.5 in wg (125 to 375 Pa) when operating with an airflow of 2000 cfm (940 L/s) in wheat. This was within acceptable limits.

EASE OF INSTALLATION AND OPERATION

Installation: The Grain Guard GG 7000 was factory installed in a Lux model LHB-514 bin. This system could not be disassembled, but could be installed in any bin with an opening of 30 in (762 mm) or more. A mounting platform for the fan had to be built, which took one man about 1 hour.

Cleaning: Ease of cleaning the Grain Guard natural air drying system was good. The screen did not plug when operating with wheat in the bin. The natural air drying system did not affect bin unloading, but some grain remained on top of the transition after emptying. Optional deflector plates are available for the transition to allow complete self-emptying.

OPERATOR SAFETY

No safety hazards were present when normal precautions were observed.

OPERATOR'S MANUAL

No operator's manual was provided. It is recommended that the manufacturer provide natural air drying guidelines with each system.

MECHANICAL HISTORY

No mechanical problems were encountered during testing. Loading the bin off-centre with wheat did not result in any mechanical damage. An optional epoxy coating was available for storing fertilizer. An extended durability test was not performed.

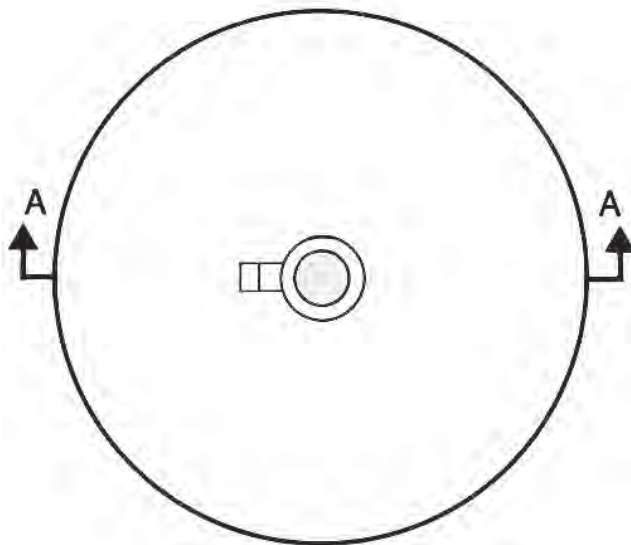
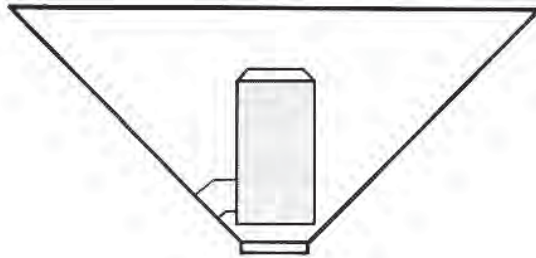
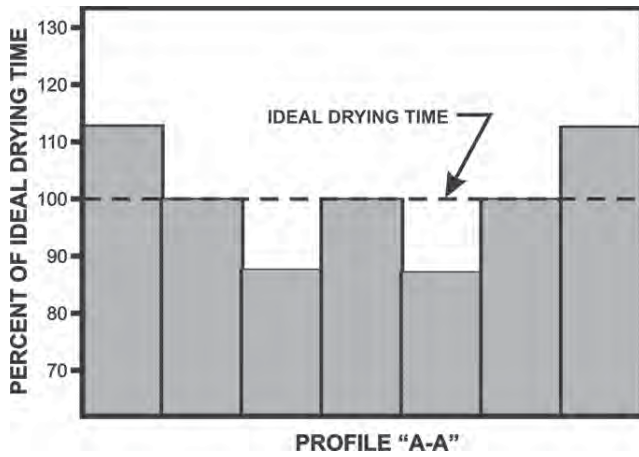

FIGURE 5. Grain Guard GG 7000 Drying Uniformity.

SPECIFICATIONS	
MAKE:	Grain Guard
MODEL:	GG 7000
AIR DISTRIBUTION SYSTEM:	
-- air transfer to grain	louvered screen
-- porosity	5.3 holes/in ² (83 holes/cm ²)
-- hole shape	oval
-- hole size	0.315 x 0.078 in (8 x 2 mm)
-- surface area	46.3 ft ² (4.3 m ²)
TRANSITION:	
-- inlet size	13.8 x 9 in (351 x 229 mm)
-- outlet size	13.8 x 9 in (351 x 229 mm)
-- length	39.5 in (1.0 m)

Keho Diamond

MANUFACTURER AND DISTRIBUTOR:

Keho Alta Products Ltd.
P.O. Box 70
Barons, Alberta
TOL 0G0
(403) 757-2444

SUMMARY AND CONCLUSIONS

Drying uniformity was good. System pressure loss was 0.5 to 1.5 in wg (125 to 375 Pa) at an airflow of 2000 cfm (940 L/s) in wheat. The natural air drying system was field installed by two men in about 4 hours. It could be installed in any bin.

Ease of cleaning the natural air drying system was very good.

The operator's manual was very good, although installation instructions were not clear. No mechanical problems were encountered. The system had to be removed for storing fertilizer.

RECOMMENDATIONS

It is recommended that the manufacturer consider:

1. Clarifying installation instructions for base angle mounting.

THE MANUFACTURER STATES THAT:

With regard to recommendation number:

1. The mounting instructions will be clarified.

GENERAL DESCRIPTION

The Keho Diamond hopper bin natural air drying system (FIGURE 6) consists of two triangular louvered screens placed side by side along the bottom of the hopper. A rectangular transition enters the side of the hopper directly under these screens to direct air from the fan to the air distribution system.

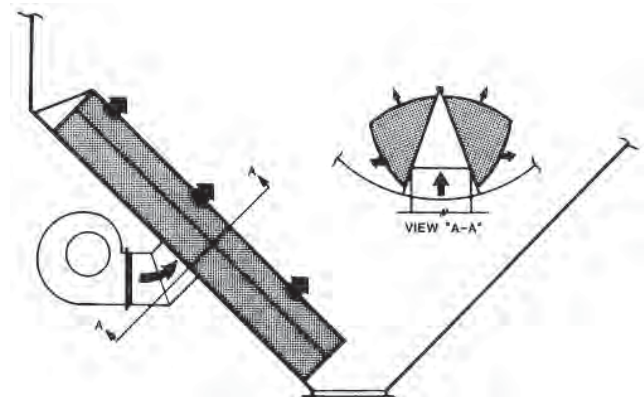

FIGURE 6. Keho Diamond Hopper Bin Natural Air Drying System.

RESULTS AND DISCUSSION

QUALITY OF WORK

Drying Uniformity: Drying uniformity with the Keho Diamond hopper bin natural air drying system was good. Airflow was higher directly above the duct than directly opposite the duct. This resulted in parts of the top layer taking 15 to 25% longer to dry completely than if the airflow uniformity throughout the bin was ideal (FIGURE 7).

System Pressure Loss: System pressure loss with the Keho Diamond natural air drying system was 0.5 to 1.5 in wg (125 to 375 Pa) when operating with an airflow of 2000 cfm (940 L/s) in wheat. This was within acceptable limits.

EASE OF INSTALLATION AND OPERATION

Installation: The Keho was installed in a Bader 1200E bin by two men in about 4 hours. The upper cap of the natural air drying system had to be modified to fit the upper ducts properly. Installing the ducts was uncomfortable as the operator had to work on the sloped surface of the hopper. The bin inlet was not predrilled, which made it possible to drill the bin inlet mounting holes in a location that would interfere with the base angles. The angle adaptor had

to be modified to fit the fan outlet, and had to be sealed to prevent air leakage during fan operation. The Keho can be installed in any hopper bin.

Cleaning: Ease of cleaning the Keho natural air drying system was very good. The screen did not plug when operating with wheat in the bin. The natural air drying system did not affect bin unloading.

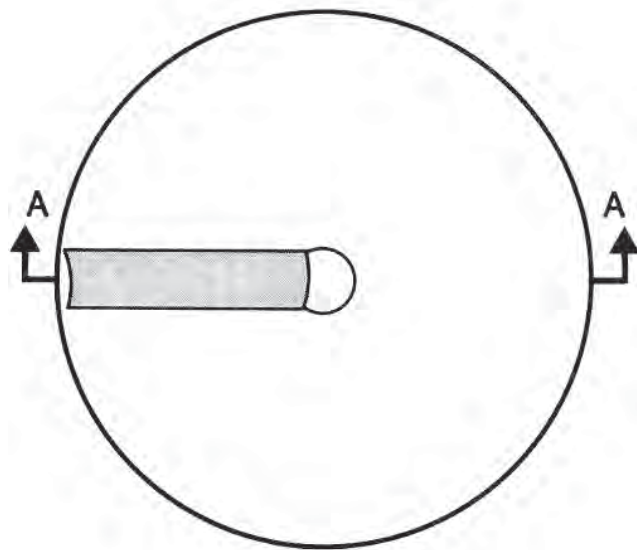
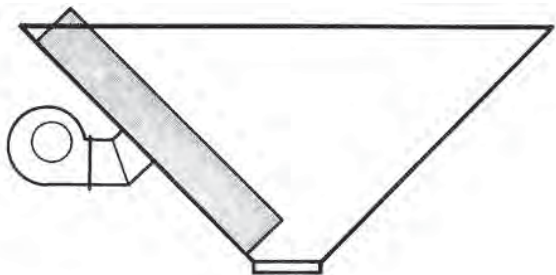
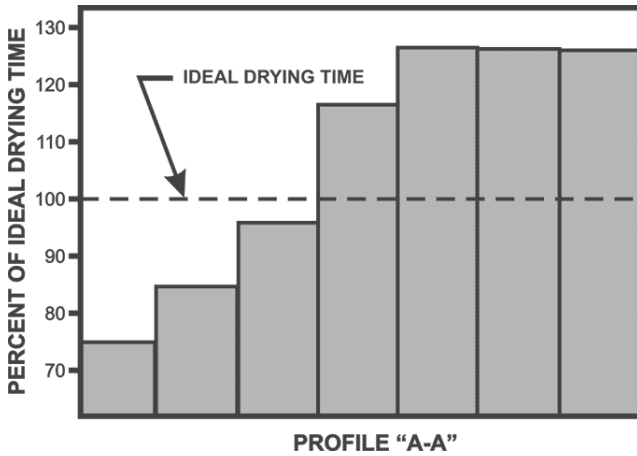

FIGURE 7. Keho Diamond Drying Uniformity.

OPERATOR SAFETY

No safety hazards were present when normal precautions were observed.

OPERATOR'S MANUAL

The instructions included with the system were very good. The installation instructions were organized and included useful illustrations, but were unclear concerning base angle mounting. It is recommended that the installation instructions be clarified. Complete natural air drying recommendations were provided.

MECHANICAL HISTORY

No mechanical problems were encountered during testing. Loading the bin off-centre with wheat did not result in any mechanical damage. The air distribution system had to be removed for storing fertilizer. An extended durability test was not performed.

SPECIFICATIONS	
MAKE:	Keho
MODEL:	15 in (38 cm) Diamond
AIR DISTRIBUTION SYSTEM:	
-- air transfer to grain	louvered screen
-- porosity	5.4 holes/in ² (0.84 holes/cm ²)
-- hole shape	oval
-- hole size	3.88 x 0.058 in (99 x 15 mm)
-- surface area	26.9 ft ² (2.5 m ²)
TRANSITION:	
-- inlet size	13.8 x 9 in (351 x 229 mm)
-- outlet size	13.8 x 9 in (351 x 229 mm)
-- length	23.2 in (590 mm)

Lode-King High Flow

MANUFACTURER AND DISTRIBUTOR:

Lode-King Industries Ltd.
P.O. Box 1146
Winkler, Manitoba
R0G 2X0
(204) 325-4345

SUMMARY AND CONCLUSIONS

Drying uniformity was very good. System pressure loss was 0.5 to 1.5 in wg (125 to 375 Pa) at an airflow of 2000 cfm (940 L/s) in wheat. The natural, air drying system was factory installed and could be field installed in some bins.

Ease of cleaning the natural air drying system was very good. No operator's manual was provided and no mechanical problems were encountered. The system had to be removed for storing fertilizer.

RECOMMENDATIONS

It is recommended that the manufacturer consider:
1. Providing natural air drying guidelines with each system.

THE MANUFACTURER STATES THAT:

With regard to recommendation number:
1. Natural air drying guidelines will be provided for future systems.

GENERAL DESCRIPTION

The Lode-King High Flow hopper bin natural air drying system (FIGURE 8) consists of three triangular louvered screens equally spaced around the hopper, and joined in the centre of the bin. A round transition enters the side of the hopper directly under one screen to deliver air to all parts of the air distribution system.

RESULTS AND DISCUSSION

QUALITY OF WORK

Drying Uniformity: Drying uniformity with the Lode-King High Flow hopper bin natural air drying system was very good. Airflow was higher directly above the air distribution screens than between the screens. This resulted in parts of the top layer taking 5 to 15% longer to dry completely than if the airflow uniformity throughout the bin was ideal (FIGURE 9).

System Pressure Loss: System pressure loss with the Lode-King High Flow natural air drying system was 0.5 to 1.5 in wg (125 to 375 Pa) when operating with an airflow of 2000 cfm (940 L/s) in wheat. This was within acceptable limits.

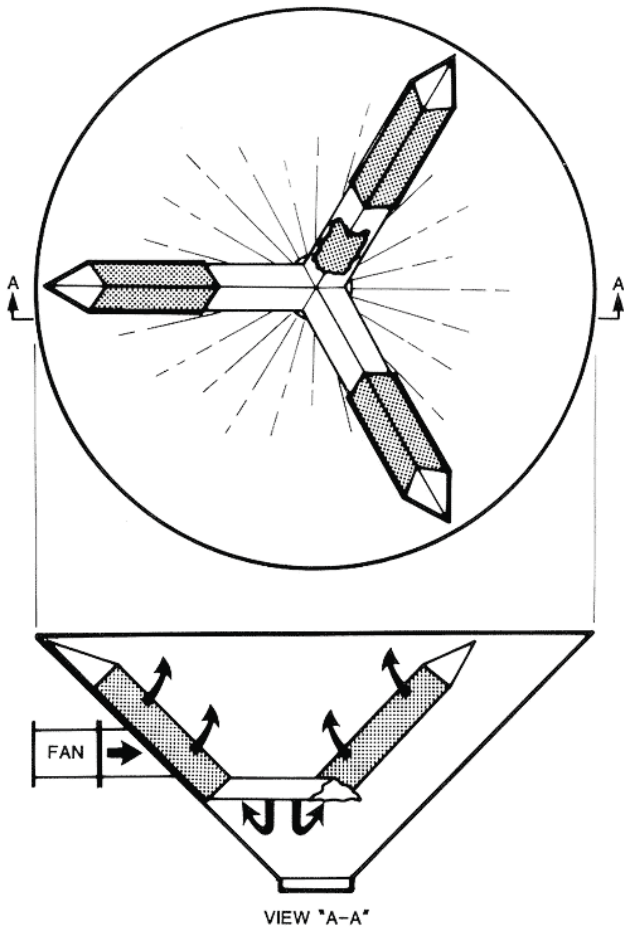

FIGURE 8. Lode-King High Flow Natural Air Drying System.

EASE OF INSTALLATION AND OPERATION

Installation: The Lode-King was factory installed in a Lode-King 14-74 bin. The system could be field installed in other makes of hopper bins with a 45 degree hopper slope.

Cleaning: Ease of cleaning the Lode-King natural air drying system was very good. The screens did not plug when operating with wheat in the bin. The natural air drying system did not affect bin unloading

OPERATOR SAFETY

No safety hazards were present when normal precautions were observed.

OPERATOR'S MANUAL

No operator's manual was provided. It is recommended that the manufacturer provide natural air drying guidelines with each system.

MECHANICAL HISTORY

No mechanical problems were encountered during testing. Loading the bin off-centre with wheat did not result in any mechanical damage. The air distribution system had to be removed for storing fertilizer. An extended durability test was not performed.

SPECIFICATIONS	
MAKE:	Lode-King
MODEL:	High Flow
AIR DISTRIBUTION SYSTEM:	
-- air transfer to grain	louvered screen
-- porosity	4.5 holes/in ² (0.7 holes/cm ²)
-- hole shape	oval
-- hole size	0.433 x 0.079 in (11 x 2 mm)
-- surface area	30.6 ft ² (2.85 m ²)
TRANSITION:	
-- inlet size	18 in (457 mm) diameter
-- outlet size	28 x 18 in (711 x 457 mm) ellipse
-- length	22 in (0.56 m)

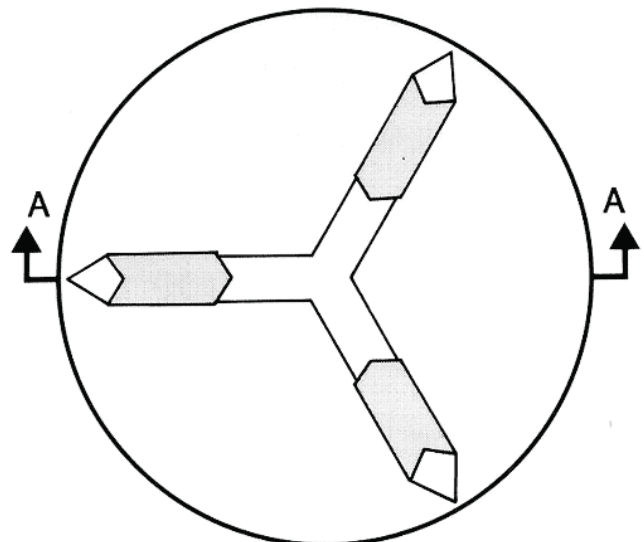
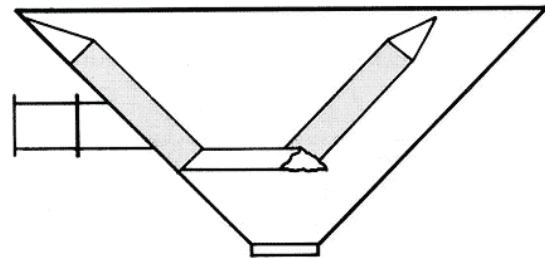
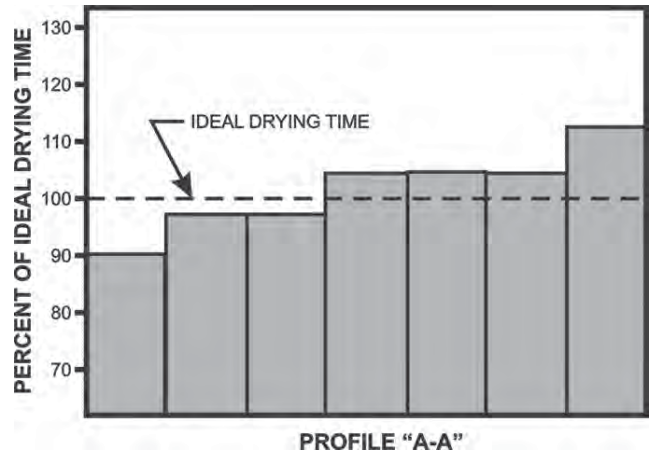

FIGURE 9. Lode-King High Flow Drying Uniformity.

Trail Rite Mark IV

MANUFACTURER AND DISTRIBUTOR:

Trail Rite Flatdecks Ltd.
 P.O. Box 1718
 Tisdale, Saskatchewan
 S0E 1T0
 (306) 873-4531

RETAIL OUTLETS:

Saskatchewan Wheat Pool Farm Service Centres

SUMMARY AND CONCLUSIONS

Drying uniformity was good. System pressure loss was 1.0 to 2.0 in wg (250 to 500 Pa) at an airflow of 2000 cfm (940 L/s) in wheat. The distribution duct was factory installed and could be field installed in some bins.

Ease of cleaning the natural air drying system was very good. The short slide-gate crank handle was potentially unsafe to operate when unloading. No operators manual was provided and no mechanical problems were encountered. The system had to be removed for storing fertilizer.

RECOMMENDATIONS

It is recommended that the manufacturer consider:

1. Lengthening the slide-gate hand crank to improve operator safety while unloading.

THE MANUFACTURER STATES THAT:

With regard to recommendation number:

1. The slide-gate hand crank will be lengthened.
2. Natural air drying guidelines will be provided for future systems.

GENERAL DESCRIPTION

The Trail Rite Mark IV hopper bin natural air drying system (FIGURE 10) consists of a cylindrical louvered screen positioned vertically at the bottom centre of the bin. A removable canvas duct is used as a transition between the fan and the air distribution screen. A vertical slide-gate with a hand crank regulates the grain flowrate during emptying.

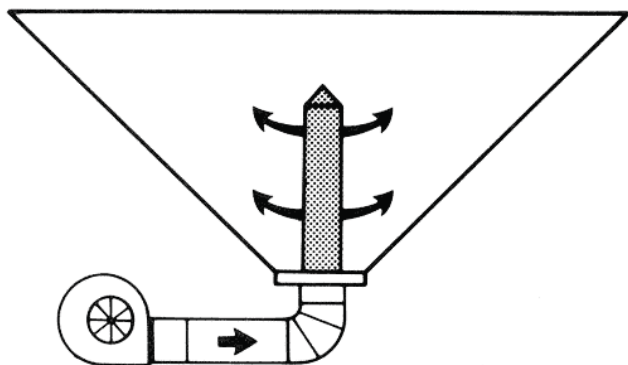

FIGURE 10. Trail Rite Mark IV Hopper Bin Natural Air Drying System.

RESULTS AND DISCUSSION

QUALITY OF WORK

Drying Uniformity: Drying uniformity with the Trail Rite Mark IV hopper bin natural air drying system was good. Airflow was higher in the centre of the bin than at the outside edges of the bin. This resulted in parts of the top layer taking 15 to 25% longer to dry completely than if the airflow uniformity throughout the bin was ideal (FIGURE 11).

System Pressure Loss: System pressure loss with the Trail Rite Mark IV natural air drying system was 1.0 to 2.0 in wg (250 to 500 Pa) when operating with an airflow of 2000 cfm (940L/s) in wheat. This was slightly above recommended limits.

EASE OF INSTALLATION AND OPERATION

Installation: The Trail Rite was factory installed in a Trail Rite FB73 hopper bin. This system can be installed in other sizes of Trail Rite bins, and can be adapted to installation in other makes of bins with 18 in (460 mm) diameter grain discharge chutes.

Cleaning: Ease of cleaning the Trail Rite natural air drying system was very good. The screen did not plug when operating with wheat in the bin, and the bin emptied completely when unloaded. The hand crank for the vertical slide-gate had to be rotated many times to fully open or close the slide-gate. The direction the crank had to be rotated for opening and closing the gate was not shown. This was inconvenient. The canvas transition was easily removed each time the bin was unloaded.

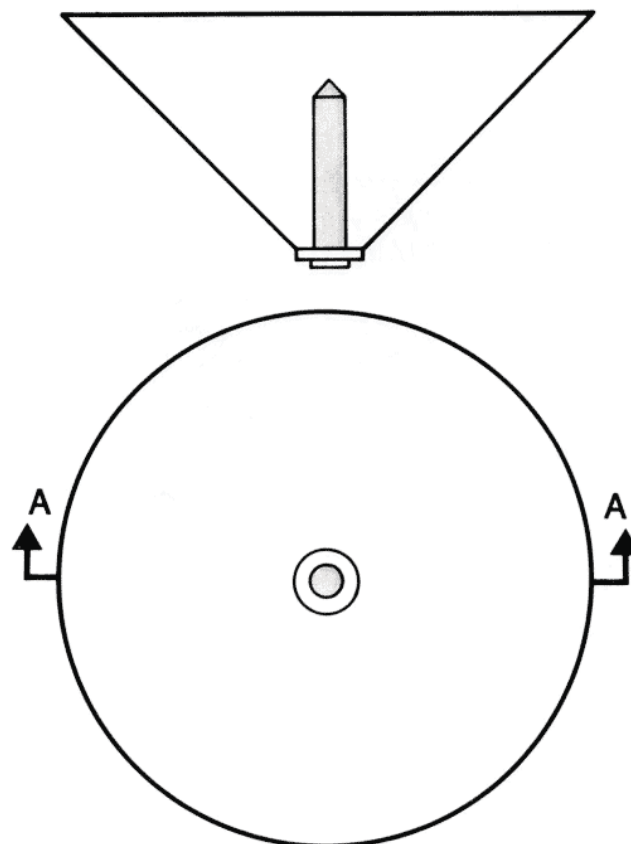
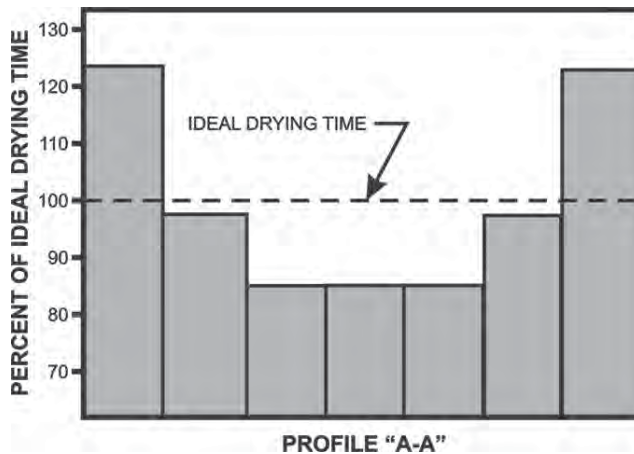

FIGURE 11. Trail Rite Mark IV Drying Uniformity.

OPERATOR SAFETY

Because the slide-gate hand crank was fairly short, the operator's hand came within 2 ft (0.6 m) of the auger intake when adjusting the slide-gate while unloading into a grain auger. It is recommended that the crank handle be lengthened to improve operator safety while unloading. No other safety hazards were present.

OPERATOR'S MANUAL

No operator's manual was provided. It is recommended that the manufacturer provide natural air drying guidelines with each system.

MECHANICAL HISTORY

No mechanical problems were encountered during testing. Loading the bin off-centre in wheat did not result in any mechanical damage. The distribution duct had to be removed for storing fertilizer. An extended durability test was not performed.

SPECIFICATIONS	
MAKE:	Trail Rite
MODEL:	Mark IV
AIR DISTRIBUTION SYSTEM:	
-- air transfer to grain	louvered screen
-- porosity	7.7 holes/in ² (1.2 holes cm ²)
-- hole shape	oval
-- hole size	0.375 x 0.060 in (9.5 x 1.5 mm)
-- surface area	18.2 ft ² (6.9 m ²)
TRANSITION:	
-- inlet size	13.8 x 9 in (351 x 229 mm)
-- outlet size	13.8 in (351 mm) diameter
-- length	60 in (152 m)

Weninger Horizontal

MANUFACTURER AND DISTRIBUTOR:

Weninger Industries Ltd.
P.O. Box 7949
Saskatoon, Saskatchewan
S7K 4R6
(306) 931-2855

RETAIL OUTLETS:

Saskatchewan Wheat Pool Farm Service Centres

SUMMARY AND CONCLUSIONS

Drying uniformity was good. System pressure loss was 0.5 to 1.5 in wg (125 to 375 Pa) at an airflow of 2000 cfm (940L/s) in wheat. Installing the natural air drying system took two men about 2 hours. It could be field installed in some bins.

Ease of cleaning the natural air drying system was good. Instructions were good, but did not include complete natural air drying guidelines. No mechanical problems were encountered. The system had to be removed for storing fertilizer.

RECOMMENDATIONS

It is recommended that the manufacturer consider:

1. Modifying the end cap to allow easy installation.
2. Clarifying the installation instructions and providing improved natural air drying guidelines with each system.

THE MANUFACTURER STATES THAT:

1. The end cap is being obtained from a different supplier and is now easier to install.
2. Better installation instructions and improved natural air drying guidelines will be supplied with future systems.

Manufacturer's Additional Comments

Since the Weninger Horizontal natural air drying system was tested, the screen length has been increased from 3.3 ft (1.0 m) to 5.5 ft (1.7 m). This may reduce system pressure loss and result in better drying uniformity than the test model.

GENERAL DESCRIPTION

The Weninger Horizontal hopper bin natural air drying system (FIGURE 12) consists of a cylindrical perforated screen positioned horizontally part way up the hopper of the bin. A round transition enters the side of the hopper to direct air from the fan to the air distribution system.

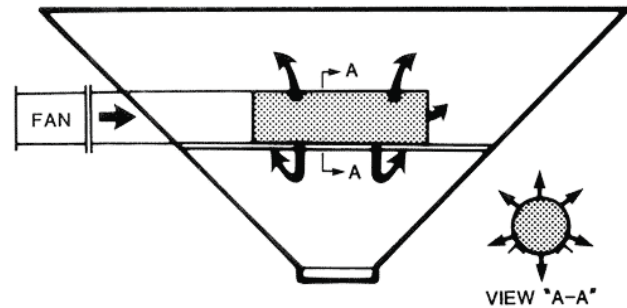

FIGURE 12. Weninger Horizontal Hopper Bin Natural Air Drying System.

RESULTS AND DISCUSSION

QUALITY OF WORK

Drying Uniformity: Drying uniformity with the Weninger Horizontal hopper bin natural air drying system was good. Airflow was higher directly above the air distribution duct than at right angles to the distribution duct at the edge of the bin. This resulted in parts of the top layer taking 15 to 25% longer to dry completely than if the airflow uniformity throughout the bin was ideal (FIGURE 13).

System Pressure Loss: System pressure loss with the Weninger Horizontal natural air drying system was 0.5 to 1.5 in wg (125 to 375 Pa) when operating with an airflow of 2000 cfm (940 L/s) in wheat. This was within acceptable limits.

EASE OF INSTALLATION AND OPERATION

Installation: The Weninger Horizontal was installed in a Bader 1200E hopper bin by two men in about 2 hours. The screened end cap was too small to easily fit on the end of the cylindrical screen, and the end cap flange was too short to easily attach to the cylindrical screen. It is recommended that the end cap be modified to permit easy installation. The Weninger Horizontal can be installed in any hopper bin with a 40 degree hopper slope.

Cleaning: Ease of cleaning the Weninger natural air drying system was good. The screen did not plug significantly when operating with wheat in the bin. The natural air drying system did not affect bin unloading, but some grain remained on top of the distribution duct after emptying.

OPERATOR SAFETY

No safety hazards were present when normal precautions were observed.

OPERATOR'S MANUAL

The instructions provided were good. They included installation procedures as well as some natural air drying guidelines. However, it was unclear where the screen support rings should be located. It is recommended that the installation instructions be clarified and that improved natural air drying guidelines be provided with each system.

MECHANICAL HISTORY

No mechanical problems were encountered during testing. Loading the bin off-centre with wheat did not result in any mechanical damage. The air distribution system had to be removed before storing fertilizer in the bin. An extended durability test was not performed.

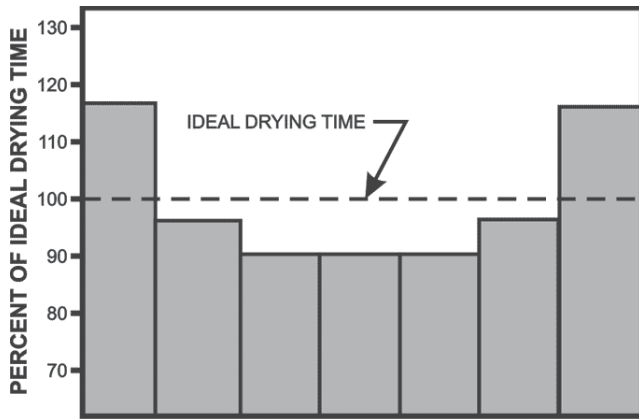

PROFILE "A-A"

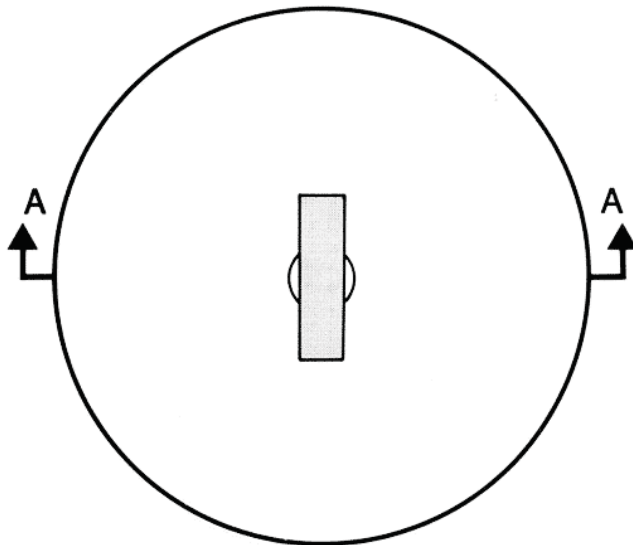
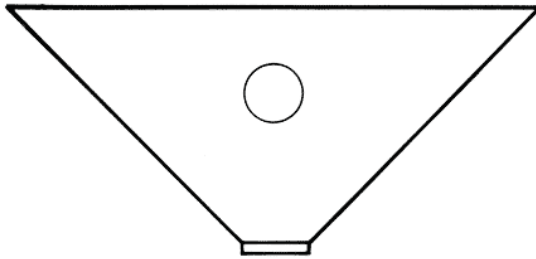

FIGURE 13. Weninger Horizontal Drying Uniformity.

SPECIFICATIONS	
MAKE:	Weninger
MODEL:	Horizontal
AIR DISTRIBUTION SYSTEM:	
-- air transfer to grain	perforated screen
-- porosity	160 holes/in ² (24.7 holes/cm ²)
-- hole shape	round
-- hole size	0.05 in (1.3 mm) diameter
TRANSITION:	
-- inlet size	17.8 in (452 mm) diameter
-- outlet size	17.8 in (452 mm) diameter
-- length	56.3 in (1.43 m)

Weninger Rocket

MANUFACTURER AND DISTRIBUTOR:

Weninger Industries Ltd
P.O. Box 7949
Saskatoon, Saskatchewan
S7K 4R6
(306) 931-2855

RETAIL OUTLETS:

Saskatchewan Wheat Pool Farm Service Centres

SUMMARY AND CONCLUSIONS

Drying uniformity was very good. System pressure loss was 0.5 to 1.5 in wg (125 to 375 Pa) at an airflow of 2000 cfm (940L/s) in wheat. The natural air drying system was factory installed but could be field installed in Weninger bins.

Ease of cleaning the natural air drying system was good. Instructions were very good, but did not include complete natural air drying guidelines. No mechanical problems were encountered. The system had to be removed for storing fertilizer.

RECOMMENDATIONS

It is recommended that the manufacturer consider:

1. Providing improved natural air drying guidelines with each system.

THE MANUFACTURER STATES THAT:

With regard to recommendation number:

1. Natural air drying guidelines will be improved.

GENERAL DESCRIPTION

The Weninger Rocket hopper bin natural air drying system (FIGURE 14) consists of a cylinder positioned vertically at the bottom centre of the bin. Forty holes allow air to enter the grain from the cylinder, and angled deflectors prevent grain from entering the cylinder through the holes. A removable metal 90 degree elbow is used as a transition between the fan and the air distribution system. A rotary slide-gate regulates the grain flowrate during emptying.

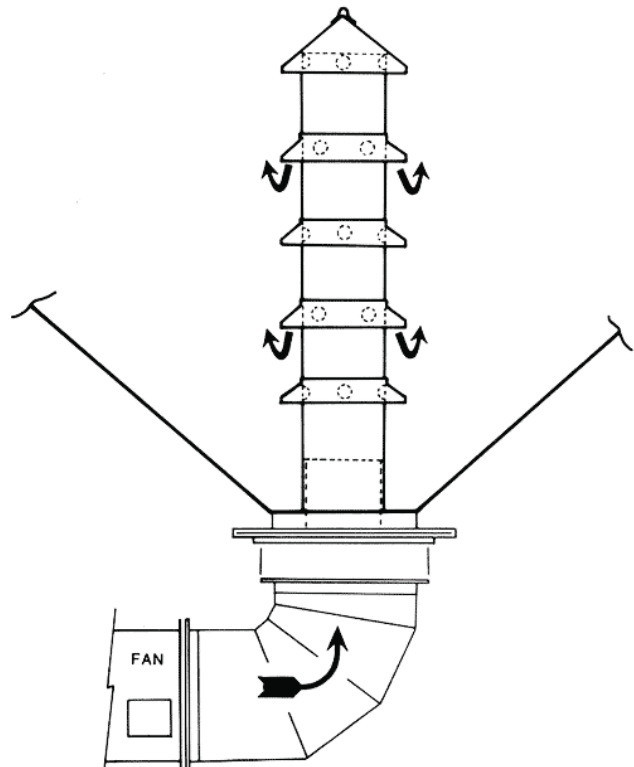

FIGURE 14. Weninger Rocket Hopper in Natural Air Drying System.

RESULTS AND DISCUSSION

QUALITY OF WORK

Drying Uniformity: Drying uniformity with the Weninger Rocket hopper bin natural air drying system was very good. Airflow was higher in the centre of the bin than at the outside edges of the bin. This resulted in parts of the top layer taking 5 to 15% longer to dry completely than if the airflow uniformity throughout the bin was ideal (FIGURE 15).

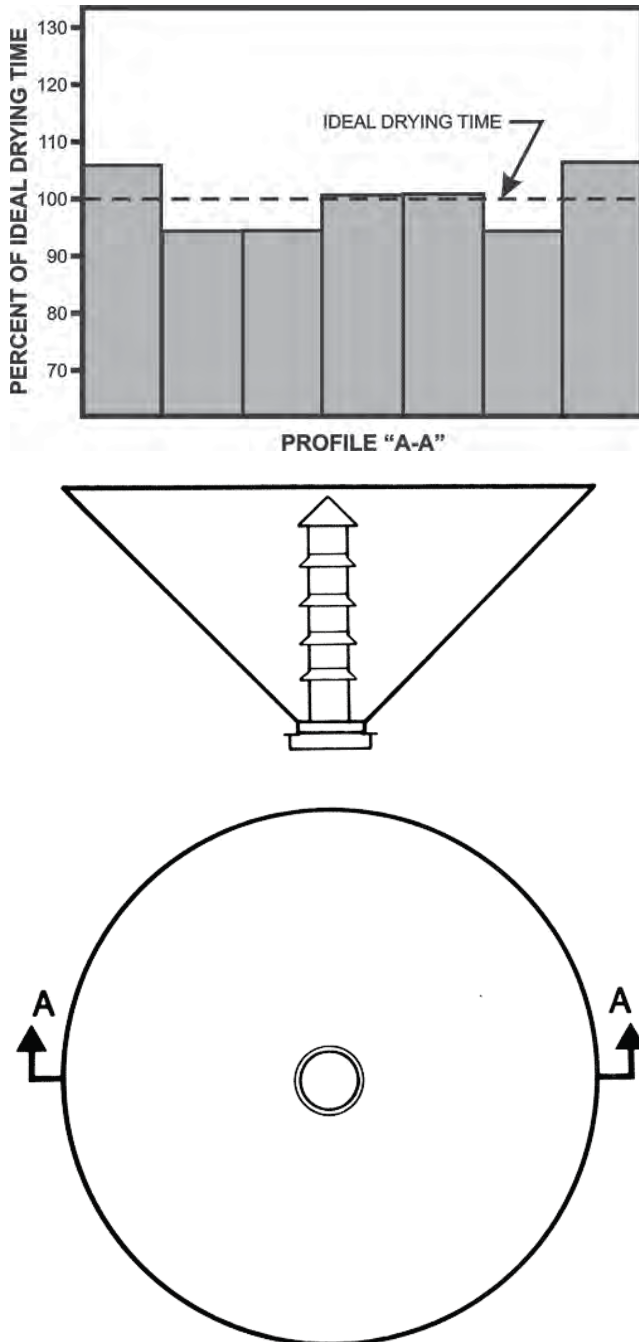

FIGURE 15. Weninger Rocket Drying Uniformity.

System Pressure Loss: System pressure loss with the Weninger Rocket natural air drying system was 0.5 to 1.5 in wg (125 to 375 Pa) when operating with an airflow of 2000 cfm (940 L/s) in wheat. This was within acceptable limits.

EASE OF INSTALLATION AND OPERATION

Installation: The Weninger was factory installed in a Weninger 73 ton (66 tonne) hopper bin. This system can be field installed in other sizes of Weninger bins by two men in about 1 hour. It is not easily adapted to installation in other makes of bins.

Cleaning: Ease of cleaning the Weninger natural air drying system was good.

No plugging occurred when operating with wheat in the bin. Operating the rotary slide-gate was convenient. The handle for the slide-gate was removable. Some grain remained at the bottom of the bin between the unloading holes, and was difficult to completely clean out. The fan and transition unit had to be removed each time the bin was unloaded. This was inconvenient, as the unit was quite heavy and awkward to maneuver.

OPERATOR SAFETY

No safety hazards were present when normal precautions were observed.

OPERATOR'S MANUAL

The instructions provided were very good. They included mounting procedures that were clear and easy to understand, as well as some natural air drying guidelines. It is recommended that the manufacturer provide improved natural air drying guidelines with each system.

MECHANICAL HISTORY

No mechanical problems were encountered during testing. Loading the bin off-centre with wheat did not result in any mechanical damage. The distribution system was not recommended for fertilizer storage. It could be removed from the bin and replaced with a conventional slide-gate, which would allow fertilizer storage. Removal takes one man about 1/2 hour. An extended durability test was not performed.

SPECIFICATIONS	
MAKE:	Weninger
MODEL:	Rocket
AIR DISTRIBUTION SYSTEM:	
-- hole shape	round
-- size	2 in (51 mm) diameter
-- number	40
-- air/grain interface area	4.25 ft ² (0.395 m ²)
TRANSITION:	
-- inlet size	18 in (457 mm) diameter
-- outlet size	18 in (457 mm) diameter
-- length	22 in (559 mm)

APPENDIX I MACHINE RATINGS	
The following rating scale is used in PAMI Evaluation Reports:	
Excellent	Fair
Very Good	Poor
Good	Unsatisfactory

**SUMMARY CHART
HOPPER BOTTOM BIN NATURAL AIR DRYING SYSTEMS**

BADER	
RETAIL PRICE	\$585.00 (April, 1986, f.o.b. Humboldt, Sask.)
QUALITY OF WORK	
- Drying Uniformity	Very Good
- System Pressure Loss	0.5 to 1.5 in wg (125 to 375 Pa)
EASE OF INSTALLATION AND OPERATION	
- Installation	Factory installation only
- Cleaning	Very Good
OPERATOR SAFETY	No safety hazards
OPERATOR'S MANUAL	None provided
MECHANICAL HISTORY	No mechanical problems, epoxy coated for storing fertilizer

TRAIL RITE MARK IV	
RETAIL PRICE	\$843.00 (April, 1986, f.o.b. Humboldt, Sask.)
QUALITY OF WORK	
- Drying Uniformity	Good
- System Pressure Loss	1.0 to 2.0 in wg (250 to 500 Pa)
EASE OF INSTALLATION AND OPERATION	
- Installation	Factory installed or field installed in some bins
- Cleaning	Very Good; inconvenient slide-gate hand crank
OPERATOR SAFETY	Short slide-gate hand crank is potentially hazardous
OPERATOR'S MANUAL	None provided
MECHANICAL HISTORY	No mechanical problems, had to be removed for storing fertilizer

GRAIN GUARD GG 7000	
RETAIL PRICE	\$765.00 (April, 1986, f.o.b. Humboldt, Sask.)
QUALITY OF WORK	
- Drying Uniformity	Very Good
- System Pressure Loss	0.5 to 1.5 in wg (125 to 375 Pa)
EASE OF INSTALLATION AND OPERATION	
- Installation	Factory installed or field installed in some bins
- Cleaning	Good
OPERATOR SAFETY	No safety hazards
OPERATOR'S MANUAL	None provided
MECHANICAL HISTORY	No mechanical problems, optional epoxy coating for storing fertilizer

WENINGER HORIZONTAL	
RETAIL PRICE	\$487.00 (April, 1986, f.o.b. Humboldt, Sask.)
QUALITY OF WORK	
- Drying Uniformity	Good
- System Pressure Loss	0.5 to 1.5 in wg (125 to 375 Pa)
EASE OF INSTALLATION AND OPERATION	
- Installation	Took two men 2 hours, could be field installed in some bins
- Cleaning	Good
OPERATOR SAFETY	No safety hazards
OPERATOR'S MANUAL	Good; some natural air drying guidelines provided
MECHANICAL HISTORY	No mechanical problems, had to be removed for storing fertilizer

KEHO DIAMOND	
RETAIL PRICE	\$495.00 (April, 1986, f.o.b. Humboldt, Sask.)
QUALITY OF WORK	
- Drying Uniformity	Good
- System Pressure Loss	0.5 to 1.5 in wg (125 to 375 Pa)
EASE OF INSTALLATION AND OPERATION	
- Installation	Took two men 4 hours, could be installed in any bin
- Cleaning	Very Good
OPERATOR SAFETY	No safety hazards
OPERATOR'S MANUAL	Very Good; complete natural air drying guidelines provided, installation instructions not clear
MECHANICAL HISTORY	No mechanical problems, had to be removed for storing fertilizer

WENINGER ROCKET	
RETAIL PRICE	\$775.00 (April, 1986, f.o.b. Humboldt, Sask.)
QUALITY OF WORK	
- Drying Uniformity	Very Good
- System Pressure Loss	0.5 to 1.5 in wg (125 to 375 Pa)
EASE OF INSTALLATION AND OPERATION	
- Installation	Factory installed, could be field installed in Weninger bins
- Cleaning	Good
OPERATOR SAFETY	No safety hazards
OPERATOR'S MANUAL	Very Good; some natural air drying guidelines provided
MECHANICAL HISTORY	No mechanical problems, had to be removed for storing fertilizer

LODE-KING HIGH FLOW	
RETAIL PRICE	\$565.00 (April, 1986, f.o.b. Humboldt, Sask.)
QUALITY OF WORK	
- Drying Uniformity	Very Good
- System Pressure Loss	0.5 to 1.5 in wg (125 to 375 Pa)
EASE OF INSTALLATION AND OPERATION	
- Installation	Factory installed or field installed in some bins
- Cleaning	Very Good
OPERATOR SAFETY	No safety hazards
OPERATOR'S MANUAL	None provided
MECHANICAL HISTORY	No mechanical problems, had to be removed for storing fertilizer



3000 College Drive South
Lethbridge, Alberta, Canada T1K 1L6
Telephone: (403) 329-1212
FAX: (403) 328-5562
[http://www1.agric.gov.ab.ca/\\$department/deptdocs.nsf/all/eng6627](http://www1.agric.gov.ab.ca/$department/deptdocs.nsf/all/eng6627)

Prairie Agricultural Machinery Institute

Head Office: P.O. Box 1900, Humboldt, Saskatchewan, Canada S0K 2A0
Telephone: (306) 682-2555

Test Stations:
P.O. Box 1060
Portage la Prairie, Manitoba, Canada R1N 3C5
Telephone: (204) 239-5445
Fax: (204) 239-7124

P.O. Box 1150
Humboldt, Saskatchewan, Canada S0K 2A0
Telephone: (306) 682-5033
Fax: (306) 682-5080