

# Evaluation Report

# 293

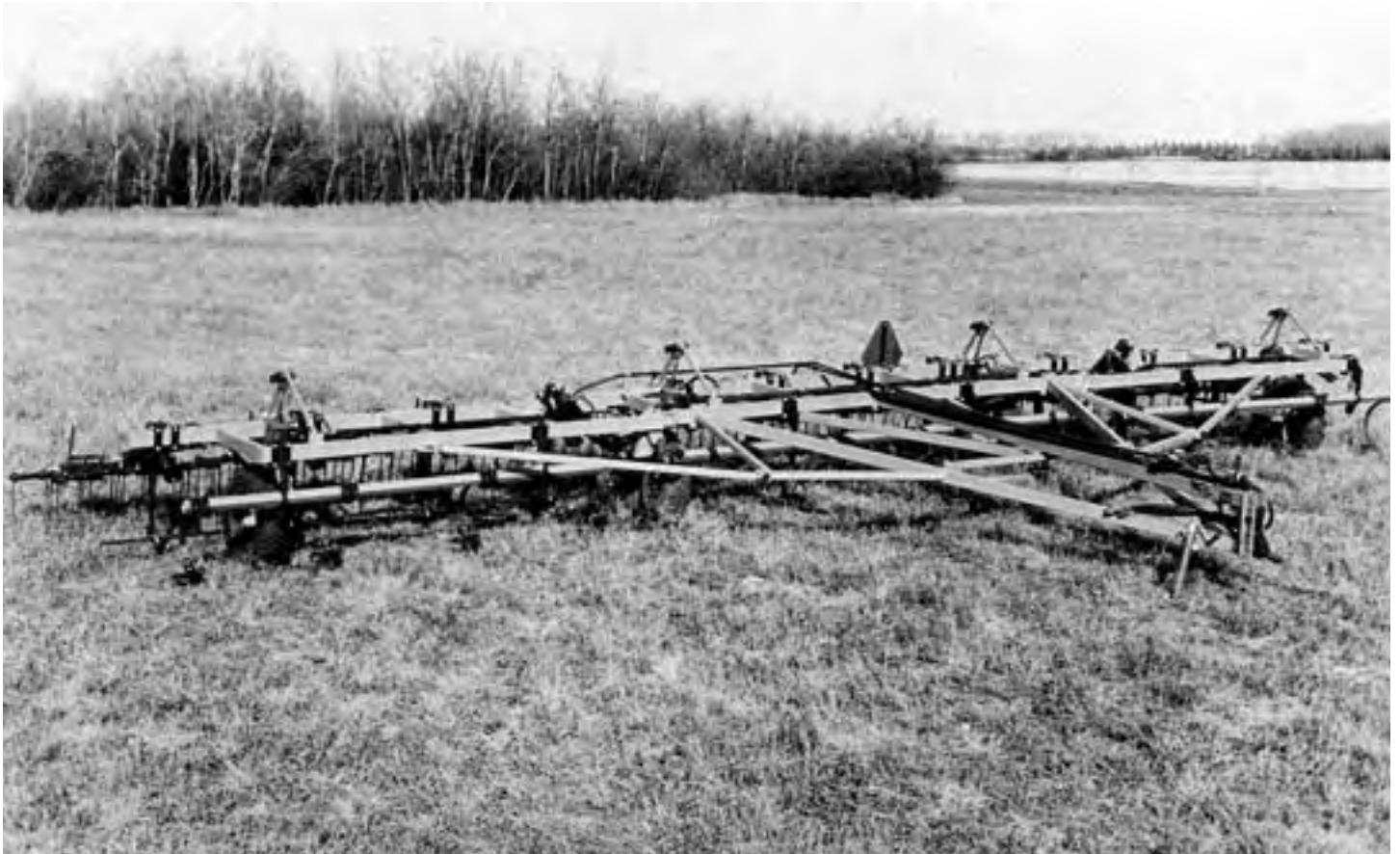

## Rite-Way RD-9600 (11.3 m) Rod Weeder

A Co-operative Program Between



## RITE-WAY RD-9600 ROD WEEDER

### MANUFACTURER AND DISTRIBUTOR:

Rite-Way Manufacturing Co. Ltd.  
P.O. Box 3344  
Regina, Saskatchewan  
S4P 3H1

### RETAIL PRICE:

\$10,770.00 (December, 1982, f.o.b. Humboldt, 11.3 m width, with ground driven rod, optional mounted finishing harrows, and cultivator shanks.)

\$11,800.00 (as above but with hydraulic driven rod.)

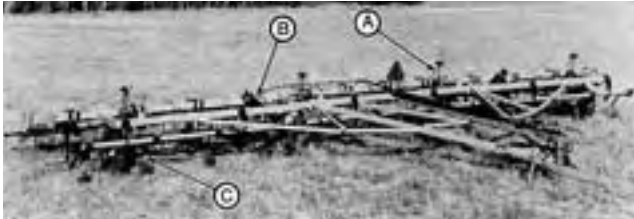

FIGURE 1. Rite-Way RD-9600: (A) Depth Control Cylinders, (B) Wing Lift Cylinders, (C) Cultivator Shanks.

### SUMMARY AND CONCLUSIONS

The overall functional performance of the Rite-Way RD-9600 was fair for light tillage operations such as seedbed preparation and secondary summerfallow. Performance was reduced by poor rod shank trip performance in stony conditions, and uneven penetration caused by drifting of the depth control cylinders.

The spring-trip rod shanks could lift 190 mm (7.5 in) to clear stones. Although this trip height was adequate, high trip forces caused some rod shank damage. The spring and rubber cushioned cultivator shanks could lift 170 mm (6.7 in) to clear stones. No shank damage occurred, but some damage occurred to the shank holders.

Penetration was good in most light tillage operations. The cultivator shanks aided penetration of the rod in firm soils. In hard soils, the cultivator shank spacing was insufficient to loosen the soil for adequate rod penetration. Uniform penetration was obtained only when the depth control cylinders were frequently synchronized. Plugging occurred in heavy or damp trash between the rod shanks and wheel locations. Large quantities of trash accumulated in the mounted harrows in moderate trash conditions. The Rite-Way RD-9600 buried less trash than most cultivators. Sideways skewing occurred only in hilly conditions. Weed kill was very good and depended on tillage depth and moisture conditions. In moist conditions and light trash, the mounted harrows were effective in exposing loosened weeds.

The Rite-Way RD-9600 could be easily placed into transport position in less than five minutes. The ground clearance of 135 mm (5.3 in) and the wheel tread of 3.2 m (10.5 ft) were adequate for safe transport. The Rite-Way RD-9600 towed well at normal transport speeds. The tire loads in transport position with mounted harrows exceeded the Tire and Rim Association maximum rating for the tires supplied by 80%. The 11.3 m (37 ft) wide test machine had a transport height of 4.4 m (14.3 ft), which was slightly less than the minimum power line heights for the three prairie provinces. Extreme caution was required to ensure safe passage under power lines.

A hitch jack was provided for easy hitching. Adjustment at the hitch provided adequate fore-and-aft levelling. No adjustments were provided for lateral levelling.

Average draft for the 11.3 m (37 ft) wide test machine with the cultivator shanks, in secondary tillage at 8 km/h (5 mph), varied from 13.5 kN (3040 lb) at 25 mm (1 in) depth to 23.6 kN (5310 lb) at 75 mm (3 in) depth. In secondary tillage with the cultivator shanks removed, at 8 km/h (5 mph), average draft varied from 10.1 kN (2270 lb) at 25 mm (1 in) depth to 18.0 kN (4050 lb) at 75 mm (3 in) depth.

In secondary tillage, at 8 km/h (5 mph) and 50 mm (2 in) depth, a tractor with 71 kW (92 hp) maximum power take-off rating will

have sufficient power reserve to operate the 11.3 m (37 ft) wide Rite-Way RD-9600 with the cultivator shanks. In secondary tillage with the cultivator shanks removed, at the same depth and speed, a 55 kW (71 hp) tractor is needed.

The Rite-Way RD-9600 was equipped with wing transport locks for safe towing. Transport locks were not provided for the centre section depth control wheels. A slow moving vehicle sign was provided. The operator's manual required more detailed operating and safety information.

Some mechanical problems occurred during the 133 hours of field operations. Several rod shank springs were permanently stretched. A lower chain sprocket broke and a rod shank bent. Several cultivator shank holders cracked, and the hitch link failed.

### RECOMMENDATIONS

It is recommended that the manufacturer consider:

1. Modifying the rod shank trip mechanism to eliminate binding, permanent spring deformation, and rod shank bending.
2. Modifications to eliminate drifting of the hydraulic depth control cylinders.
3. Modifications to provide smaller increments of depth adjustment.
4. Equipping the rod weeder with tires that comply with the Tire and Rim Association load rating.
5. Modifying the hitch link to provide adequate vertical swivel.
6. Modifications to eliminate cultivator shank holder failures.
7. Providing lateral levelling adjustment to ensure level operation.
8. Providing a transport lock for the depth control cylinders.
9. Providing larger diameter cotter pins for the rod shank pivot pins.
10. Relocating the hitch jack to provide greater handle clearance.
11. Routing the hydraulic hoses to prevent interference with moving components.
12. Providing adequately sized sweep bolts to prevent the bolt heads from turning when removing the sweeps.
13. Supplying more detailed operating and safety information in the operator's manual.
14. Working with the agricultural equipment industry to standardize hydraulic quick couplers and hydraulic hose fitting threads.

Senior Engineer: G. E. Frehlich

Project Technologist: A. R. Boyden

### THE MANUFACTURER STATES THAT

With regard to recommendation number:

1. The shank trip mechanism will be modified to eliminate binding of the tension springs.
2. A new hydraulic depth control cylinder design will be used in all future production.
3. The new cylinder will incorporate fine increments of depth control.
4. The tires on the transport wheels will comply with Tire and Rim Association load rating.
5. We will consider this.
6. Stricter quality control will be implemented.
7. We have been relying on adjustments of the cylinder rod clevis for lateral levelling.
8. We will consider this.
9. to 12. These will be incorporated in all future productions.
13. We will consider publishing a new operator's manual.
14. We are very willing to work with the agricultural equipment industry to standardize these components.

**NOTE:** This report has been prepared using SI units of measurement. A conversion table is given in APPENDIX III.

## GENERAL DESCRIPTION

The Rite-Way RD-9600 is a trailing, flexible, three-section rod weeder suitable for light tillage such as seedbed preparation and secondary summerfallow. It is available only in an 11.3 m (37 ft) model, with a 4 m (13.1 ft) centre frame and two 3.6 m (11.8 ft) wings. The rod may be ground driven or hydraulic driven. The centre and right sections of the test machine were equipped with hydraulic driven rods while the left wing was equipped with a ground driven rod. The ground rod is supported by 12 spring trip shanks. The rod for each section consists of three rods coupled by chain link connectors. The 12 cultivator shanks are spaced at 1.2 m (3.9 ft) on the centre section and 1 m (3.3 ft) on the wing sections in a single row across the front of the machine.

The centre frame is carried on two wheels, while each wing is supported by a single wheel. Tillage depth is controlled by four hydraulic cylinders connected in series. Two hydraulic cylinders connected in parallel fold the wings into an upright position. A tractor with dual remote hydraulic controls is needed to operate the Rite-Way RD9600.

Detailed specifications are given in APPENDIX I while FIGURE 1 shows the location of major components.

## SCOPE OF TEST

The Rite-Way RD-9600 was operated in the field conditions shown in TABLE 1, for 133 hours, while tilling about 1178 ha (2900 ac). It was evaluated for quality of work, ease of operation and adjustment, power requirements, safety and suitability of the operator's manual.

The cultivator shanks and optional mounted harrows were used during most of the test.

TABLE 1. Operating Conditions

Field Condition	Hours	Area (ha)
Soil Type		
light loam	16	149
sandy loam	5	37
loam	70	607
clay	13	98
heavy clay	29	287
Total	133	1178
Stony Phase		
stone free	25	229
occasional stones	64	525
moderately stony	34	328
very stony	10	96
Total	133	1176

## RESULTS AND DISCUSSION

### QUALITY OF WORK

**Shank Characteristics:** The Rite-Way RD-9600 was equipped with adjustable spring-trip rod shanks. FIGURE 2 shows the lifting pattern of the rod shanks when stones or field obstructions were encountered. The maximum lift height was 190 mm (7.5 in). Several springs caught on the trip mount when tripping and were permanently stretched. The force required to trip the rod shanks varied greatly. One rod shank bent during the tests.

The cultivator shanks were equipped with a cushion spring and a rubber mounted shank holder. FIGURE 3 shows the lifting pattern when the cultivator shanks encountered stones or field obstructions. The maximum lift height was 170 mm (6.7 in).

Shank tripping was restricted by binding at the shank pivot point. Several shank holders failed during the tests.

**Penetration:** Penetration was good in most light tillage operations such as seedbed preparation and secondary summerfallow.

The cultivator shanks aided penetration in firm soils. In hard soils, the shank spacing was insufficient to loosen the soil ahead of the rod, resulting in poor rod penetration and weed misses.

The wing sections frequently penetrated deeper than the centre section. This was due to continuous drifting of the wing depth control cylinders. Frequent synchronization of the depth control system by fully extending the hydraulic cylinders was required. It is recommended that the manufacturer consider modifications to eliminate continuous drifting of the hydraulic depth control cylinders.

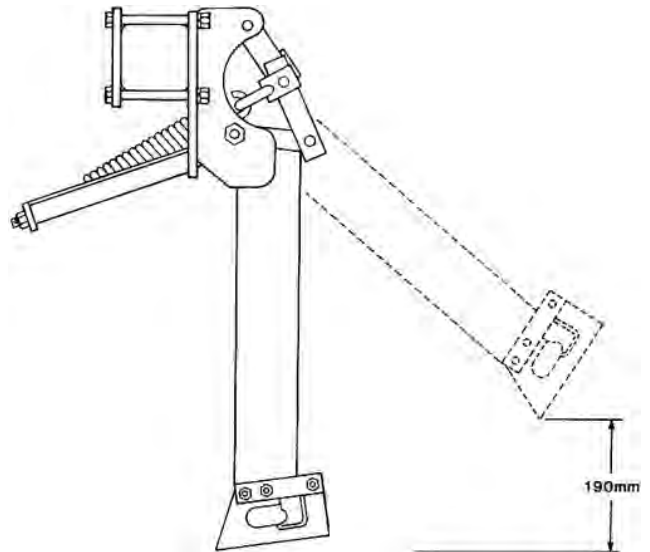

FIGURE 2. Rod Shank Lifting Pattern.

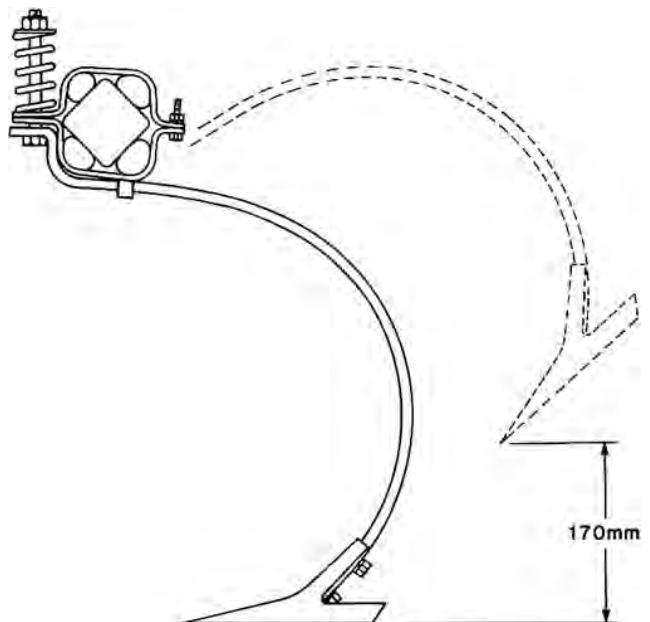

FIGURE 3. Cultivator Shank Lifting Pattern.

The wheels were adequately sized and positioned to provide good flotation. In normal secondary tillage, the frame remained level with little twisting of the wing frames.

The Rite-Way RD-9600 followed gently rolling field contours well. The similar widths of the centre and wing sections resulted in fairly uniform penetration across the rod weeder width in rolling fields. As with most wing tillage implements, large variations in tillage depth occurred in fields with abrupt contour changes.

**Plugging:** The Rite-Way RD-9600 cleared trash well in moderate trash conditions. Plugging occurred at the wheel locations in heavy trash.

The mounted harrows plugged easily in moderate to heavy trash conditions when set at a steep tine angle. Reducing the tine angle improved trash clearance.

**Trash Burial and Surface Conditions:** The rod shanks located directly behind the cultivator shanks, left deep furrows when the cultivator shanks were used. These furrows were usually filled in by the finishing harrows, resulting in a uniform seedbed (FIGURE 4). Only slight furrows were produced when the cultivator shanks were not used. In typical summerfallow, the Rite-Way RD-9600 buried less trash than most heavy duty cultivators (FIGURE 5).

**Skewing and Stability:** The Rite-Way RD-9600 was stable and sideways skewing only occurred on hillsides. The location of the rod shanks and cultivator shanks (FIGURE 6) did not impose any side forces on the rod weeder during normal tillage.



FIGURE 4. Typical Seedbed Preparation With Mounted Harrows and With Cultivator Shanks Removed.



FIGURE 5. Typical Summerfallow With Cultivator Shanks and Harrows.

**Weed Kill:** Weed kill was very good in soft soil conditions. In firm soils, weed misses occurred in the tractor wheel tracks. Moving a cultivator shank into the tractor wheel track improved the weed kill in these areas. Many weed misses occurred in hard soils due to inadequate rod penetration. As with most rod weeders, a shallow working depth increased soil disturbance and produced a better weed kill. Some weeds in moist conditions were able to pass over the rod with little root disturbance. The mounted harrows were effective in exposing these weeds when set at a steep tine angle. In moderate to heavy trash conditions, the reduced tine angle required to clear trash was less effective.

**EASE OF OPERATION AND ADJUSTMENT**

**Transporting:** The Rite-Way RD-9600 could be easily placed

into transport position in less than five minutes (FIGURE 7). On machines equipped with hydraulic driven rods, a selector valve on the hitch frame of the rod weeder had to be manually switched before the wings could be raised for transport. The wing transport lock pins were easily installed once the wing stops were properly adjusted. A transport lock was not provided for the depth control system. It is recommended that the manufacturer supply a transport lock for the depth control cylinders.

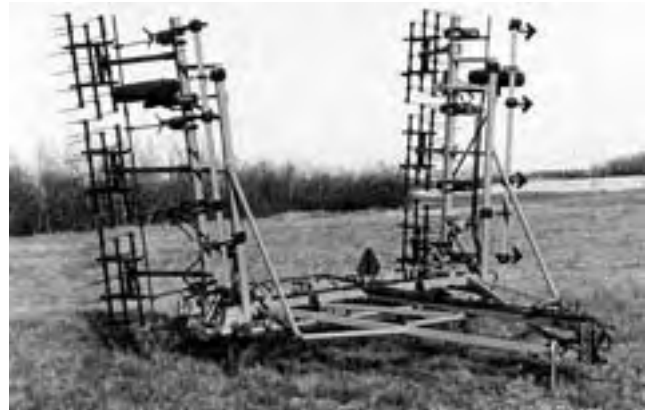

FIGURE 7. Transport Position.

For high transport speeds or long distances, the rod drive shaft on machines equipped with ground driven rods could be disconnected by removing two bolts.

Transport width was 6.1 m (20 ft) while transport height was 4.4 m (14.3 ft). Care was needed when transporting on public roads, through gates, over bridges and beneath power and telephone lines.

The Rite-Way RD-9600 towed well without sway at normal transport speeds. The rod shank ground clearance of 135 mm (5.3 in) and a wheel tread of 3.2 m (10.5 ft) usually provided adequate ground clearance during transport.

**Hitching:** The hitch jack, supported hitch link, and positive hitch weight of the Rite-Way RD-9600 made one-man hitching easy, even with mounted harrows. However, the clearance between the jack handle and the hitch frame was restricted. It is recommended that the manufacturer relocate the hitch jack to provide greater handle clearance.

The hitch height could be easily adjusted 690 mm (27 in) in twelve increments by removing one pin. This range was adequate

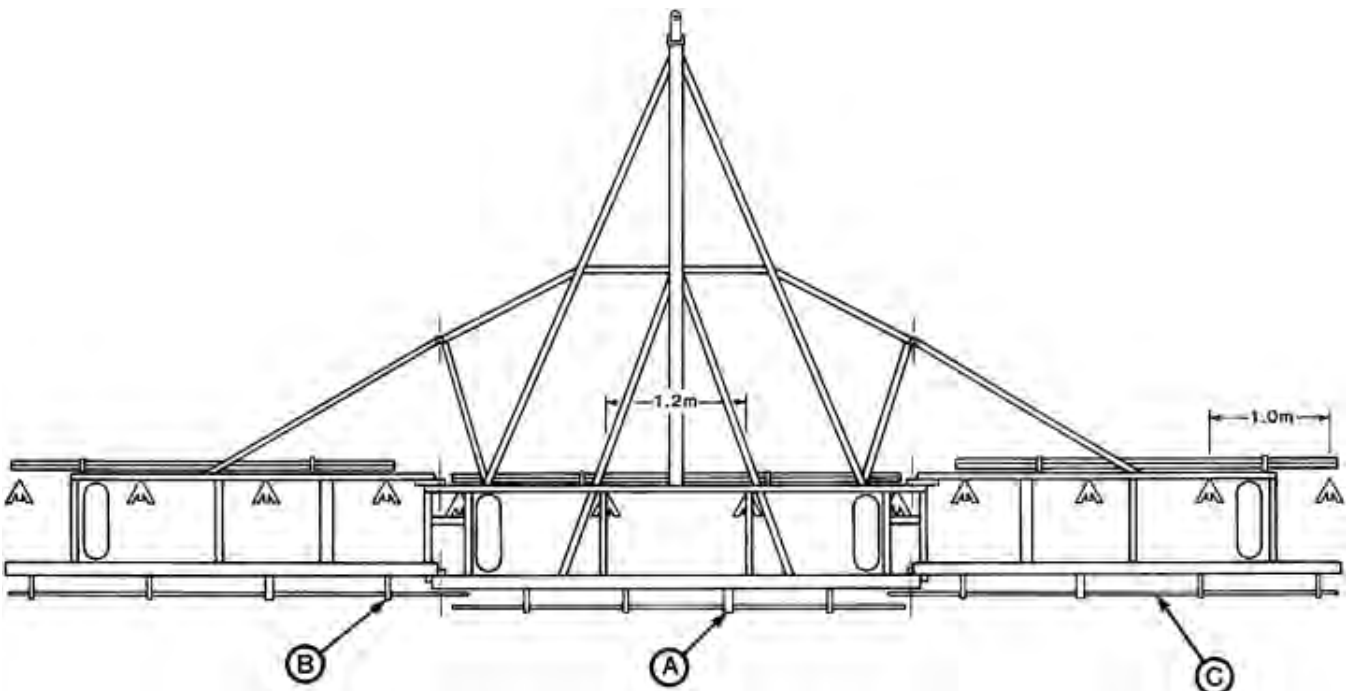

FIGURE 6. Shank Pattern (A) Rod Drives, (B) Rod Support Shanks, (C) Rod.

to allow fore-and-aft frame levelling with all tractors used during the test.

**Maneuverability:** The hitch frame of the Rite-Way RD-9600 was narrow permitting normal turns without tractor wheel interference.

**Frame Levelling:** No lateral levelling adjustments were provided for the centre or wing sections. It is recommended that the manufacturer provide lateral levelling adjustments to ensure level operation.

**Depth of Tillage:** Tillage depth was controlled with four hydraulic cylinders connected in series. Only two depth control stop collars were provided and these did not allow small increments of depth adjustment. It is recommended that the manufacturer consider modifications to provide smaller increments of depth adjustment. Frequent synchronization of the cylinders, by completely extending them to a fully raised position, was necessary to maintain the centre and wing sections at the same depth.

**Sweep and Rod Support Bracket Installation:** It took one man about one hour to remove and replace the 12 cultivator sweeps on the Rite-Way RD-9600. The carriage heads on the sweep bolts were too small to prevent the bolts from turning and several bolts had to be cut off to remove the sweeps. It is recommended that the manufacturer provide adequately sized sweep bolts to prevent the bolt heads from turning when removing the sweeps. The sweep-to-ground clearance of 135 mm (5.3 in) was adequate for sweep removal.

It took one man about one and one-half hours to replace the 12 rod support brackets.

**Shank Installation:** A cultivator shank could be replaced in less than 15 minutes by removing the sweep and the shank spring bolt. The rod weeder could be operated without the cultivator shanks by removing six pins and rotating the cultivator shank frame.

## POWER REQUIREMENTS

**Draft Characteristics:** FIGURE 8 shows draft requirements for rod weeders in typical secondary tillage, at a speed of 8 km/h (5 mph). This figure gives average requirements based on tests of six makes of rod weeders. Attempting to compare draft requirements of different makes of rod weeders usually is unrealistic. Variations in soil conditions affect draft much more than variations in machine make, usually making it impossible to measure any significant draft differences between different makes of rod weeders.

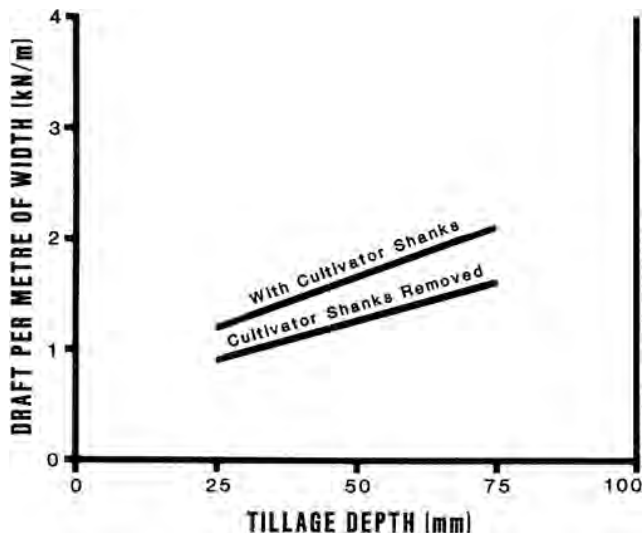

FIGURE 8. Average Draft Requirements for Rod Weeders in Secondary Tillage at 8 km/h.

In secondary tillage when equipped with 12 cultivator shanks equally spaced in a single row at the front of the machine, average draft per metre of width, at 8 km/h (5 mph), varied from 1.2 kN/m (82 lb/ft) at 25 mm (1 in) depth to 2.1 kN/m (144 lb/ft) at 75 mm (3 in) depth. For the 11.3 m (37 ft) wide test machine, this corresponds to a total draft ranging from about 13.5 to 23.6 kN (3040 to 5310 lb).

In secondary tillage with the cultivator shanks removed, the average draft per metre of width, at 8 km/h (5 mph), varied from 0.9 kN/m (62 lb/ft) at 25 mm (1 in) depth to 1.6 kN/m (110 lb/ft) at 75 mm (3 in) depth. For the 11.3 m (37 ft) wide test machine this

corresponds to a total draft ranging from about 10.1 to 18.0 kN (2270 to 4050 lb).

**Tractor Size:** TABLES 2 and 3 show tractor sizes needed to operate the 11.3 m (37 ft) Rite-Way RD-9600 in secondary tillage with and without cultivator shanks, respectively. Tractor sizes have been adjusted to include tractive efficiency and represent a tractor operating at 80% of maximum power on a level field. The sizes presented in the tables are the maximum power take-off rating as determined by Nebraska tests or as presented by the tractor manufacturer. Selected tractor sizes will have ample power reserve to operate the Rite-Way RD-9600 in the stated conditions.

Tractor size may be determined by selecting the desired tillage depth and speed from the appropriate table. For example, in secondary tillage at 50 mm (2 in) depth and 8 km/h (5 mph) a 71 kW (92 hp) tractor is needed to operate the Rite-Way RD-9600. In secondary tillage with the cultivator shanks removed, at the same depth and speed, a 55 kW (71 hp) tractor is needed.

TABLE 2. Tractor Size (Maximum Power Take-Off Rating, kW) to Operate the 11.3 m Wide Rite-Way RD-9600 in Secondary Tillage with Cultivator Shanks

Depth (mm)	Speed (km/h)					
	7	8	9	10	11	12
25	43	51	60	69	78	88
50	61	71	83	94	106	119
75	79	92	105	120	134	150

TABLE 3. Tractor Size (Maximum Power Take-Off Rating, kW) to Operate the 11.3 m Wide Rite-Way RD-9600 in Secondary Tillage with the Cultivator Shanks Removed

Depth (mm)	Speed (km/h)					
	7	8	9	10	11	12
25	33	39	45	52	59	66
50	47	55	63	72	81	90
75	61	71	81	92	103	114

## OPERATOR SAFETY

Extreme caution is needed in transporting most folding implements to avoid contacting power lines. Minimum power line heights vary in the three prairie provinces. In Saskatchewan, the energized line may be as low as 5.2 m (17 ft) over farmland or over secondary roads. In Alberta and Manitoba, the neutral ground wire may be as low as 4.8 m (15.8 ft) over farmland. In all three provinces, lines in farmyards maybe as low as 4.6 m (15 ft). Transport height of the 11.3 m (37 ft) wide test machine was 4.4 m (14.3 ft), permitting safe passage under prairie power lines. The legal responsibility for safe passage under utility lines rests with the machinery operator and not with the power utility or the machinery manufacturer. All provinces have regulations governing maximum permissible equipment heights on various types of public roads. If height limits are exceeded, the operator must contact the power and telephone utilities before moving.

The Rite-Way RD-9600 was 6.1 m (20 ft) wide in transport position. This necessitated caution when transporting on public roads, over bridges and through gates. A slow moving vehicle sign was provided.

Transport locks were provided for the wings but not for the depth control wheels. It is recommended that the manufacturer supply a depth control lock as standard equipment.

The Rite-Way RD-9600 towed well at speeds up to 32 km/h (20 mph). The centre section tire loads in transport position with mounted harrows, exceeded the Tire and Rim Association maximum rating for 7.6L x 15, 4-ply tires by 80%. This tire overload was considered unsafe and hazardous, especially at high transport speeds. It is recommended that the rod weeder be equipped with tires having suitable load ratings.

## STANDARDIZATION

**Hydraulics:** During the test, considerable difficulty was encountered due to differences in hydraulic couplers on various tractors. The difficulty was in the lack of standardization both in couplers and in hose threads. More standardization is needed in this area.

## OPERATOR'S MANUAL

The operator's manual included a complete parts list and brief

operating instructions. It is recommended that the manufacturer provide more detailed operating and safety information.

**DURABILITY RESULTS**

TABLE 4 outlines the mechanical history of the Rite-Way RD-9600 during 133 hours of field operation while tilling about 1178 ha (2900 ac). The intent of the test was evaluation of functional performance. The following mechanical problems represent those, which occurred during functional testing. An extended durability evaluation was not conducted.

**TABLE 4.** Mechanical History

Item	Operating Hours	Equivalent Field Area (ha)
<b>Shanks:</b>		
A rod shank spring was permanently stretched at	36, 43, 113	274, 332, 883
The cotter pin on a rod shank pivot pin sheared off and was replaced at	43, 115, 133	332, 907, 1178
Four cultivator shank holders cracked	during the test	
A chain sprocket broke when a rod shank failed to return after tripping at	125	1004
A rod drive shank bent at	128	1026
<b>Hydraulics:</b>		
The hoses for the hydraulic driven rod were rerouted at	beginning of test	
<b>Frame:</b>		
The hitch link failed at	119	941

**DISCUSSION OF MECHANICAL PROBLEMS**

**Shanks:** Five rod shank springs were permanently stretched when they caught on the trip mount while tripping. Binding within the trip mechanism caused the rod shank to remain in a tripped position (FIGURE 9). This stopped the rod rotation and caused the lower rod chain sprocket to break.



**FIGURE 9.** Rod Shank in Tripped Position.

A rod shank bent due to the high force required to trip the shank. It is recommended that the manufacturer modify the rod shank trip to eliminate binding, permanent spring deformation, and rod shank bending.

The cotter pins for the rod shank pivot pins were too small and were easily sheared off. These pins were replaced with larger diameter pins and no further problems occurred. It is recommended that the manufacturer provide larger diameter cotter pins for the rod shank pivot pins.

Binding at the shank pivot prevented the cultivator shank from tripping and caused the four shank holder failures. It is recommended that the manufacturer consider modifications to eliminate cultivator shank holder failures.

**Hydraulics:** The hoses for the hydraulic rod drive interfered with the rod shank trip mechanisms and were rerouted at the beginning of the tests. It is recommended that the manufacturer reroute the hydraulic hoses to prevent interference with moving components.

**Frame:** The hitch link failed while operating in a field with abrupt contour changes (FIGURE 10). It is recommended that the manufacturer modify the hitch link to allow adequate vertical

swivel.



**FIGURE 10.** Hitch Link Failure.

**APPENDIX I  
SPECIFICATIONS**

**MAKE:** Rite-Way Rod Weeder  
**MODEL:** RD-9600  
**SERIAL NUMBER:** 82-01  
**MANUFACTURER:** Rite-Way Manufacturing Co. Ltd.  
P. O. Box 3344  
Regina, Saskatchewan S4P 3H1

DIMENSIONS:	Field Position	Transport Position
-- width	11,250 mm	6080 mm
-- length	5100 mm	5100 mm
-- height	330 mm	4350 mm
-- maximum ground clearance	135 mm	135mm
-- wheel tread	9515 mm	3200 mm

**RODS:**

- number of rods 9
- number of rods to each section 3
- rod size 25 mm
- drive type
  - left section hydraulic driven
  - centre and right section ground driven

**SHANKS:**  
**rod shanks**

- number 12
- lateral spacing
  - centre section 838 mm
  - wing sections 991 mm
- trash clearance (frame to rod) 635 mm
- shank cross-section
  - driven 38 x 160 mm
  - non-driven 13 x 100 mm

**cultivator shanks**

- number 12
- lateral spacing
  - centre section 1219 mm
  - wing sections 1016 mm
- trash clearance (frame to sweep tip) 465 mm
- shank cross-section 13 x 45 mm
- shank stem angle 45°
- sweep hole spacing 45 mm
- sweep bolt size 3/8 x 1-1/4 in

**HITCH:**

- vertical adjustment range 690 mm

**DEPTH CONTROL:** hydraulic

**FRAME:**

- cross-section
- front frame member 102 x 51 mm tubing, 6 mm thick
- rear frame member 102 mm square tubing, 6 mm thick

**TIRES:**

- centre section 2, 7.6L x 15, 4-ply
- wings 2, 7.6L x 15, 4-ply

**NUMBER OF LUBRICATION POINTS:**

- ground drive model 68 grease fittings, daily service  
4 wheel bearings, yearly service
- hydraulic drive model 56 grease fittings, daily service  
4 wheel bearings, yearly service

**HYDRAULIC CYLINDERS:**

- depth control 1, 76 x 203 mm  
1, 83 x 203 mm  
1, 89 x 203 mm  
1, 95 x 203 mm
- wing lift 2, 76 x 356 mm

WEIGHTS: (Without Harrows)	Field Position	Transport Position
-- right wheel	283 kg	
-- right centre wheels	489 kg	775 kg
-- left centre wheels	521 kg	800 kg
-- left wheel	300 kg	
-- hitch	180 kg	198 kg
<b>TOTAL</b>	1773 kg	1773 kg

WEIGHTS: (With Mounted Harrows)	Field Position	Transport Position
-- right wheel	382 kg	
-- right centre wheels	726 kg	1096 kg
-- left centre wheels	752 kg	1138 kg
-- left wheel	398 kg	
-- hitch	18 kg	52 kg
<b>TOTAL</b>	2286 kg	2286 kg

**OPTIONAL EQUIPMENT:**

- ground driven or hydraulic driven rods
- mounted finishing harrows

**APPENDIX II  
MACHINE RATINGS**

The following rating scale is used in Machinery Institute Evaluation Reports:

(a) excellent	(d) fair
(b) very good	(e) poor
(c) good	(f) unsatisfactory

**APPENDIX III  
CONVERSION TABLE**

1 kilometre/hour (km/h)	= 0.6 miles/hour (mph)
1 metre (m)	= 3.3 feet (ft)
1 millimetre (mm)	= 0.04 inches (in)
1 kilogram (kg)	= 2.2 pounds mass (lb)
1 kilowatt (kW)	= 1.3 horsepower (hp)
1 hectare (ha)	= 2.5 acres (ac)
1 kilonewton (kN)	= 220 pounds force (lb)
1 kilonewton/metre (kN/m)	= 70 pounds force/foot (lb/ft)



3000 College Drive South  
Lethbridge, Alberta, Canada T1K 1L6  
Telephone: (403) 329-1212  
FAX: (403) 329-5562  
<http://www.agric.gov.ab.ca/navigation/engineering/afmrc/index.html>

**Prairie Agricultural Machinery Institute**

Head Office: P.O. Box 1900, Humboldt, Saskatchewan, Canada S0K 2A0  
Telephone: (306) 682-2555

Test Stations:  
P.O. Box 1060  
Portage la Prairie, Manitoba, Canada R1N 3C5  
Telephone: (204) 239-5445  
Fax: (204) 239-7124

P.O. Box 1150  
Humboldt, Saskatchewan, Canada S0K 2A0  
Telephone: (306) 682-5033  
Fax: (306) 682-5080