

# Evaluation Report

# 401

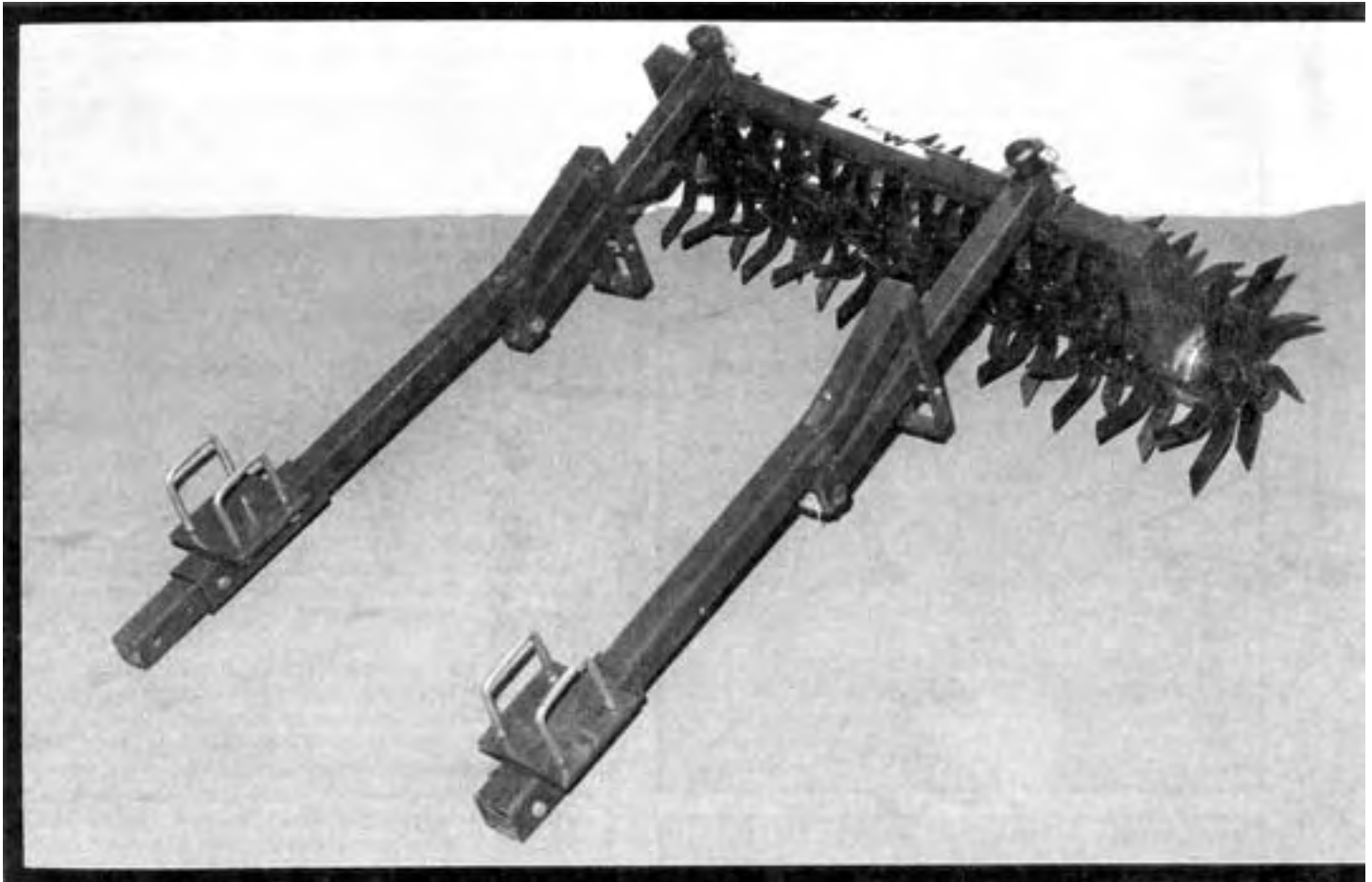

## Miller Rotary Flex Weeders

A Co-operative Program Between



## MILLER ROTARY FLEX WEEDERS

### MANUFACTURER:

Miller Weeder Corp.  
Stratton, Nebraska 69043  
U.S.A.

### RETAIL PRICE:

\$1,015.00 [January, 1985, f.o.b. Humboldt, Saskatchewan, 5.5 ft (1.7 m) wide unit].

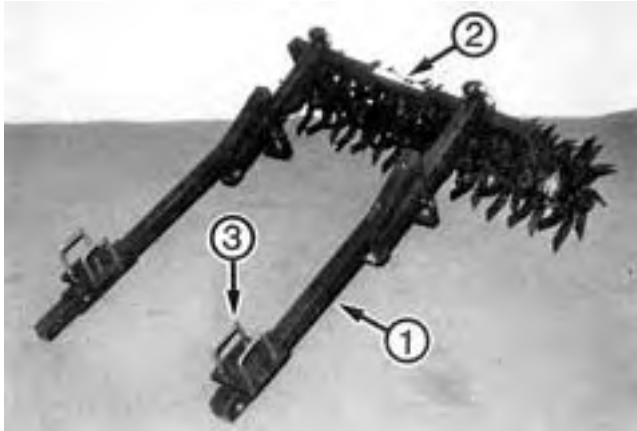

FIGURE 1. Miller Rotary Flex Weeders: (1) Hitch Arms, (2) Frame, (3) Mounting Brackets.

### SUMMARY AND CONCLUSIONS

**Quality of Work:** The Miller Rotary Weeders left an even field surface in most field conditions resulting in a very good soil finish. The weeders could be adjusted to penetrate to the tillage depth to provide very good soil mixing for chemical incorporation, except in heavy trash. The ability of the weeders to spread trash was poor. In moderate to heavy trash, the weeders would wrap and plug when adjusted for more aggressive tillage. Packing was good. Packing force was 42 lb/ft (610 N/m), which is less than light coil packers. The weeders could be adjusted to provide good weed kill or to anchor the straw and trash to reduce erosion.

**Ease of Installation:** Ease of installation was good. Two people were required to install the Miller Weeders. No installation instructions were supplied. Weeder sizes and adjustments were adequate to permit mounting the weeders without interfering with cultivator components.

**Ease of Operation and Adjustment:** Ease of transporting the Miller Weeders was fair. Height adjustment was inadequate to prevent the Miller Weeders from contacting road surfaces when transporting. Hitch weight may become negative on some implements with the added weight of the weeders. Ease of adjusting the weeders was fair as it usually required two men to adjust the weeder angle. Rocks frequently jammed between the weeder teeth and frame, stopping rotation. Ease of servicing the weeders was very good.

**Power Requirements:** The Miller Weeder required 0.5 hp/ft (1.2 kW/m) of tractor power to maintain a speed of 6 mph (9.7km/h). This was slightly less than mounted tine harrows. More power was required at higher weeder angles.

**Safety:** Caution was required when working on or near the weeders due to the sharp points on the weeder teeth.

**Operator's Manual:** No operator's manual was supplied with the weeders.

**Mechanical History:** Many teeth broke on the original weeders when operating in fields with only a few rocks. These original weeders were unsuitable and were replaced by the manufacturer. Teeth on the replacement weeders were frequently bent when operating in fields with many large rocks.

### RECOMMENDATIONS:

It is recommended that the manufacturer consider:

1. Modifications to prevent rocks or roots from jamming the weeders and stopping rotation.

2. Modifications to prevent straw from wrapping around the weeders and causing plugging.
3. Producing weeders with the opposite edge of the teeth pointed so they can be alternated with the present weeders to prevent implement skew.
4. Modifications to the mounting brackets to allow mounting on different frame sizes.
5. Modifications to increase the transport clearance,
6. Modifications to permit easier and safer weeder angle adjustment.
7. Providing complete installation and operating instructions.
8. Modifications to improve durability of the weeder teeth.

Senior Engineer: G.E. Frehlich

Project Engineer: H.D. Kydd

### THE MANUFACTURER STATES THAT:

With regard to recommendation number:

1. Taller frame sizes are available to permit additional rock and root clearance.
2. The tooth design has been changed. In heavy trash conditions the Flex Weeders should be run in the normal direction at a less severe weeder angle.
3. Teeth with the opposite edge pointed are now an option.
4. Standard mounts fit a 4 x 4 in (100 x 100 mm) implement frame. Other frame mounts or weld-on brackets are available.
5. Modifications have been incorporated in the new Flex Weeder design
6. Modifications have been incorporated in the new Flex Weeder design.
7. Instructions have been included with the new Flex Weeder.
8. Modifications have been incorporated in the new Flex Weeder design.

### GENERAL DESCRIPTION

The Miller Rotary Flex Weeders are mounted behind cultivators or other tillage machines and are used for weed kill, seedbed preparation, chemical incorporation, and soil finishing. The weeders are available in widths of 4.5, 5.0, 5.5, 6.0, and 6.5 ft (1.4, 1.5, 1.7, 1.8, and 2.0 m) with hitch arm lengths of 4.4, 5.3 or 6.1 ft (1.3, 1.6 or 1.9 m).

Each Miller Weeder consists of 9 sets of 8 pointed teeth welded to a central axle. Two hitch arms and mounting brackets attach the weeder to the cultivator frame.

The wide range of adjustments from packing to very aggressive tillage are provided to suit many different field conditions. The weeders can be turned end-for-end to reverse the direction of rotation (FIGURE 2), resulting in a more aggressive digging action.

The hitch arms can be lengthened or shortened to change the weeder angle (FIGURE 3). Increasing the weeder angle increases the aggressiveness of the weeder.

Interchanging the hitch arms so the opposite end of the weeder is leading changes the tooth action (FIGURE 4). Each tooth has one pointed edge. More aggressive tooth action and tillage is obtained when this pointed edge is leading rather than trailing.

FIGURE 1 shows the locations of major components while detailed specifications are given in APPENDIX 1.

### SCOPE OF TEST

Two 5.5 ft (1.7 m) Miller Weeders were mounted on an intermediate cultivator. These original weeders were removed after only a few hours because many of the teeth had broken off while hitting rocks. The manufacturer supplied two replacement weeders, which were operated for 23 hours while cultivating stubble and summerfallow. Thirteen of these hours were spent in stony fields. The weeders were evaluated for quality of work, ease of installation, operation and adjustment, power requirements, and safety.

### RESULTS AND DISCUSSION

#### QUALITY OF WORK

**Soil Finish:** The Miller Weeders adequately smoothed the soil ridges left by an intermediate cultivator resulting in a very good soil

finish (FIGURE 5) with less soil pulverizing than with mounted tine harrows. However, in fields with rocks or roots, the weeders could not be used in the reversed direction for more aggressive tillage since rocks and roots jammed the weeders, stopping rotation. This occurred occasionally even with the weeders rotating in the normal direction (FIGURE 6). It is recommended that the manufacturer consider modifications to prevent rocks and roots from jamming the weeders and stopping rotation.

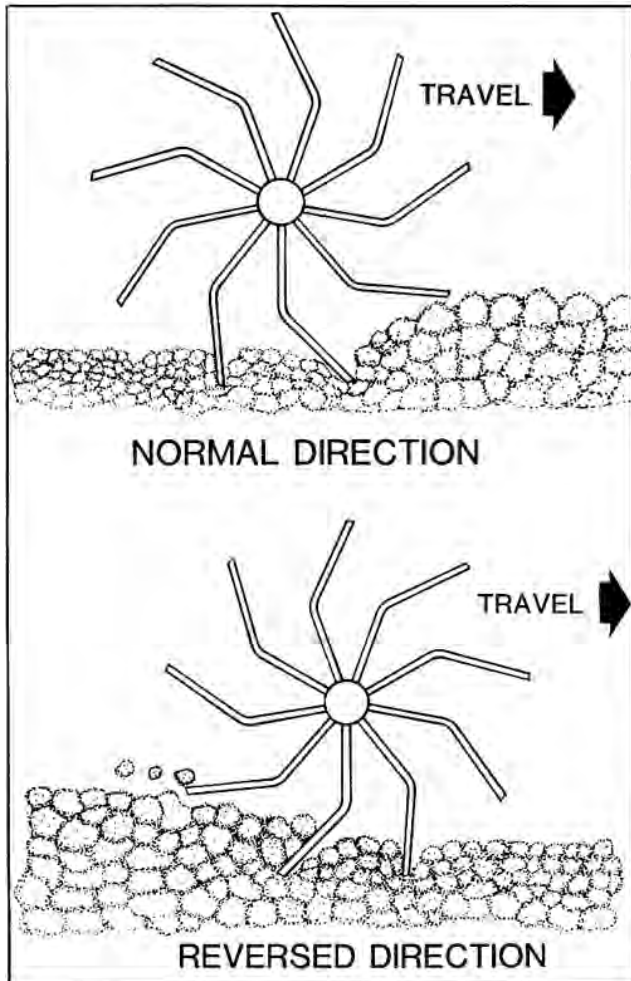

FIGURE 2. Direction of Rotation.

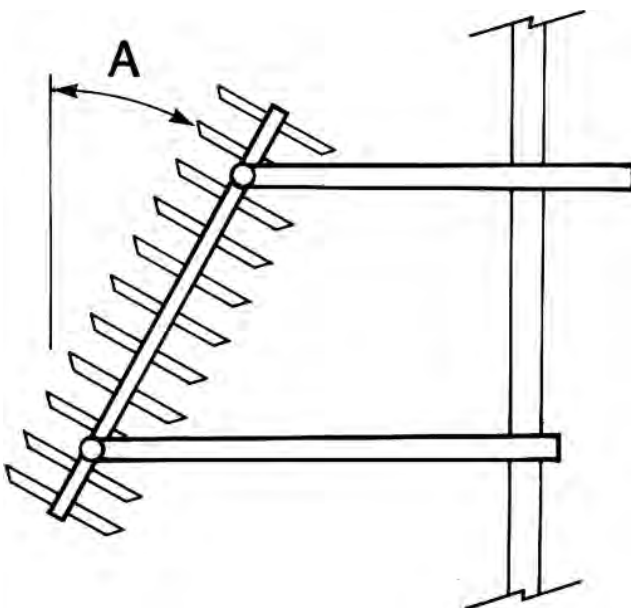

FIGURE 3. Weeder Angle (A).

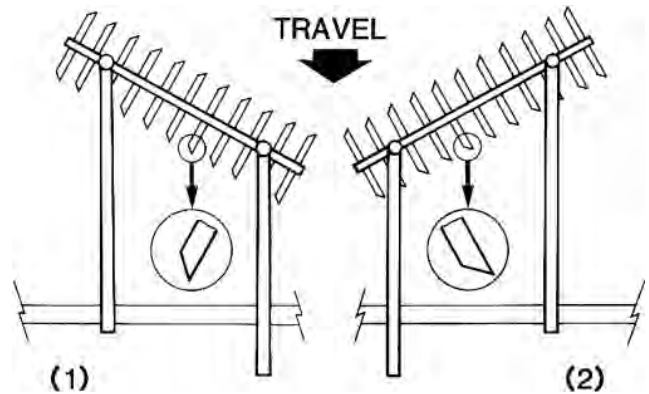

FIGURE 4. Weeder Tooth Action: (1) Tooth Point Leading, (2) Tooth Point Trailing.

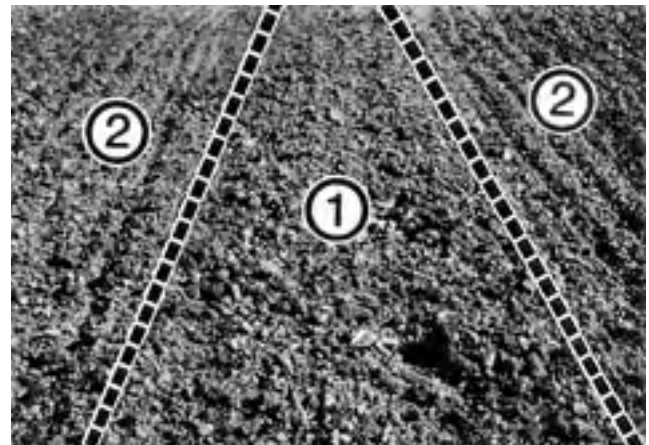

FIGURE 5. Field Surface: (1) Miller Weeders, (2) Mounted Tine Harrows.



FIGURE 6. Rock Jams.

**Chemical Incorporation:** The Miller Weeders could be adjusted to penetrate to the tillage depth to provide very good soil mixing for chemical incorporation, especially when the pointed edges of the teeth were leading.

**Straw Spreading:** The ability of the Miller Weeders to spread straw was poor. When adjusted for more aggressive tillage, straw wrapped around the weeders and caused plugging (FIGURE 7). It is recommended that the manufacturer consider modifications to prevent straw from wrapping around the weeders and causing plugging.

**Packing:** Packing by the Miller Weeders was good. The packing force was 42 lb/ft (610 N/m), which is less than light coil packers.

**Weed Kill:** The weed killing ability of the weeders was good depending on the moisture content of the soil. The weeders could be adjusted to aid in exposing the weeds. When adjusted for packing, the weeders pushed the trash and weeds into the soil. This anchored the trash and helped reduce erosion in dry loose soils. However, if the soil was moist, some of the weeds were transplanted.

**Skewing:** When used at large weeder angles, the large side force generated by the weeders caused the cultivator to skew sideways. If weeders were available with the opposite edge of the

teeth pointed, they could be alternated with the present weeders to balance side forces and prevent cultivator skew. It is recommended that the manufacturer also produce weeders with the opposite edge of the teeth pointed.



FIGURE 7. Straw Wrapping Around the Weeders When Rotating in the Reversed Direction.

### EASE OF INSTALLATION

Ease of installing the Miller Weeders was good. It took two people approximately 1/2 hour to install each weeder on a cultivator. The mounting brackets were made to fit only a 4 x 4 in (100 x 100 mm) cultivator frame. It is recommended that the manufacturer modify the mounting brackets to allow mounting on different frame sizes.

The weeders were heavy and awkward. Caution was required when working around the pointed teeth. No instructions were provided for installing the weeders.

Care was required when sizing and positioning the weeders to prevent interference with the cultivator or other weeders. The available weeder sizes and hitch arm lengths were adequate for locating the weeders without interfering with shank tripping or folding of the cultivator for transport.

### EASE OF OPERATION AND ADJUSTMENT

**Transporting:** Ease of transporting the weeders was fair. Height adjustment was inadequate to prevent the Miller Weeders from contacting the centre of crowned roads when transporting. Extra holes were drilled in the hitch arms of the weeders mounted on the cultivator main frame to increase transport clearance. It is recommended that the manufacturer increase transport clearance.

Weeders mounted on the cultivator wing rested firmly when the wing was in the vertical position.

**Hitching:** The added weight of the Miller Weeders may result in a negative hitch weight on some implements, making hitching to a tractor drawbar inconvenient.

**Adjustments:** Ease of adjusting the Miller Weeders to suit field conditions was fair. On most farms, the weeders would have to be adjusted several times to obtain the desired packing or tilling action. Adjusting the Weeder angles was difficult and usually required two men. When adjusting the angles, the weeder arms had to be moved on the weeder frame to keep the weeder arms parallel, and to prevent interference with adjacent weeders. It is recommended that the manufacturer consider modifications to make the weeder angle adjustments easier.

**Servicing:** There were two grease fittings on each weeder. The service interval was not specified.

### POWER REQUIREMENTS

**Draft:** Average draft per foot of width for the Miller Weeder varied with the weeder angle. When operating behind an intermediate cultivator in primary tillage at an angle where plugging with trash did not occur, draft was 22 lb/ft (318 N/m). This is slightly less than mounted tine harrows and about the same as light coil packers. Draft increased considerably when operating at larger weeder angles.

**Tractor Size:** Field power measurements indicated that an additional tractor power take-off rating of 0.5 hp/ft (1.2 kW/m) was required to pull the Miller Weeders behind an intermediate cultivator

in primary tillage at 6 mph (9.7 km/h).

This power requirement must be considered when adding the weeders to an implement. For example, installing 35 ft (10.7 m) of weeders behind a cultivator will require an additional 17.5 hp (13 kW) to maintain a speed of 6 mph (9.7 km/h). This value represents power take-off rating of tractors operating at 80% of maximum power on a level field and has been adjusted to include tractive efficiency.

### OPERATOR SAFETY

Extreme caution was required when working on or near the pointed weeder teeth. Also, when adjusting angles, the hitch arms often had to be lifted free from the weeder frame, allowing the frame to swing down. This could cause an injury. It is recommended that the manufacturer consider making the weeder angle adjustment safer.

### OPERATOR'S MANUAL

An operator's manual was not supplied with the Miller Weeder. It is recommended that complete installation and operating instructions be provided.

### MECHANICAL HISTORY

The intent of the test was evaluation of functional performance. An extended durability test was not conducted.

**Broken Teeth:** Many teeth on the original weeders broke off at or near the supporting ring weld (FIGURE 8) when operating in fields with only a few rocks. These original weeders were unsatisfactory for operation in fields with any stones and were replaced after only a few hours of operation.



FIGURE 8. Broken Teeth on the Original Weeders.

**Bent Teeth:** Teeth on the replacement weeders frequently bent when hitting large rocks while working in very stony fields (FIGURE 9). The bent teeth contacted the weeder frame, stopping rotation. It is recommended that the manufacturer make modifications to improve durability of the weeder teeth.



FIGURE 9. Bent Teeth Stopping Rotation.

**APPENDIX I  
SPECIFICATIONS**

<b>MAKE:</b>	Miller Rotary Flex Weeder
<b>MODEL:</b>	55 ft (17 m) size
<b>MANUFACTURER:</b>	Miller Weeder Corp Stratton, Nebraska 69043 USA
<b>OVERALL DIMENSIONS:</b>	
-- width	5.5 ft (1.7 m)
-- cutting width	changes with weeder angle
-- length	6.8 ft (2.1 m) (changes with weeder angle)
-- diameter	18.5 in (470 mm)
-- axle diameter	2.375 in (60.5 mm)
<b>TEETH:</b>	
-- number	88
-- length	8 in (203 mm)
-- size	1.5 x 0.375 in (38 x 9.5 mm)
<b>HITCH:</b>	
-- arm length	5.3 and 6.1 ft (1.6 and 1.9 m)
-- cross section	2.5 x 2.5 x 0.25 in (64 x 64 x 6.4 mm)
-- frame mounting size	4 x 4 in (100 x 100 mm)
<b>TOTAL WEIGHT:</b>	352 lb (160 kg)
<b>SERVICING:</b>	2 grease fittings
<b>SIZES AVAILABLE:</b>	
-- widths	4.5, 5.0, 5.5, 6.0 or 6.5 ft (1.4, 1.5, 1.7, 1.8 or 2.0 m)
-- hitch length	4.4 5.3 or 6.1 ft (1.3, 1.6 or 1.9 m)

**APPENDIX II  
MACHINE RATINGS**

The following rating scale is used in Machinery Institute Evaluation reports:

excellent	far
very good	poor
good	unsatisfactory

## SUMMARY CHART

### MILLER ROTARY FLEX WEEDER

<b>RETAIL PRICE</b>	\$1,015.00 [January, 1985, f.o.b Humboldt, Sask., 5.5 ft (1.7 m) wide unit].
<b>QUALITY OF WORK</b>	
Soil Finish	<b>Very Good;</b> less soil pulverization than with mounted tine harrows, anchored loose trash
Chemical Incorporation	<b>Very Good;</b> except in heavy trash
Straw Spreading	<b>Poor;</b> not effective in spreading trash, plugged when adjusted for aggressive tillage
Packing	<b>Good;</b> 42 lb/ft (610 N/m)
Weed Kill	<b>Good;</b> when adjusted for aggressive tillage
<b>EASE OF INSTALLATION</b>	<b>Good;</b> awkward to handle
<b>EASE OF OPERATION AND ADJUSTMENT</b>	
Transporting	<b>Fair;</b> transport clearance was inadequate
Adjusting	<b>Fair;</b> usually required 2 men
Servicing	<b>Very Good;</b> 2 grease fittings for each weeder
<b>POWER REQUIREMENTS</b>	
Draft	22 lb/ft (318N/m) behind an intermediate cultivator in primary tillage at 6 mph (9.7 km/h)
Power Required	0.5 hp/ft (1.2 kW/m) at 6 mph (9.7 km/h)
<b>SAFETY</b>	Sharp pointed teeth are a safety hazard
<b>OPERATOR'S MANUAL</b>	No operator's manual provided
<b>MECHANICAL HISTORY</b>	Many teeth broke on the original weeders, several teeth bent on the replacement weeders



3000 College Drive South  
 Lethbridge, Alberta, Canada T1K 1L6  
 Telephone: (403) 329-1212  
 FAX: (403) 329-5562  
<http://www.agric.gov.ab.ca/navigation/engineering/afmrc/index.html>

#### Prairie Agricultural Machinery Institute

Head Office: P.O. Box 1900, Humboldt, Saskatchewan, Canada S0K 2A0  
 Telephone: (306) 682-2555

Test Stations:  
 P.O. Box 1060  
 Portage la Prairie, Manitoba, Canada R1N 3C5  
 Telephone: (204) 239-5445  
 Fax: (204) 239-7124

P.O. Box 1150  
 Humboldt, Saskatchewan, Canada S0K 2A0  
 Telephone: (306) 682-5033  
 Fax: (306) 682-5080