

# Evaluation Report

62



## Co-op Implements 204 (8.3 m) Heavy Duty Cultivator

A Co-operative Program Between



## CO-OP IMPLEMENTS 204 HEAVY DUTY CULTIVATOR

### MANUFACTURER AND DISTRIBUTOR:

Canadian Co-operative Implements Limited  
770 Pandora Avenue East  
Winnipeg, Manitoba  
R2C 3N1

### RETAIL PRICE:

\$7,521.10 (May, 1979, f.o.b. Humboldt, 8.3 m width, with optional finishing harrows), less ground tools.

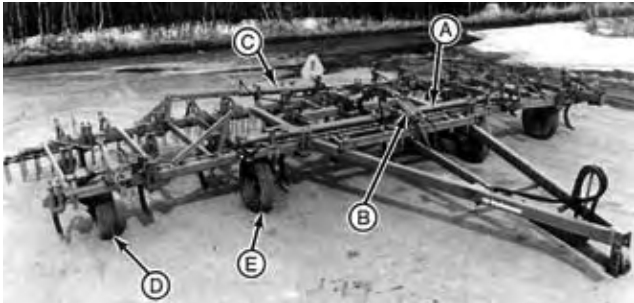

FIGURE 1. CI 204: (A) Depth Control Rockshaft, (B) Depth Control Cylinder, (C) Wing Lift Cylinder, (D) Wing Wheels, (E) Centre Wheels.

### SUMMARY AND CONCLUSIONS

The overall functional performance of the Co-op Implements 204 heavy duty cultivator was good. Its performance was reduced by inadequate shank lift heights of the shank cushioning assemblies.

The spring cushioned shanks could lift only 95 mm (3.8 in) to clear stones. This limited clearance resulted in several bent shanks when operating in stony land. When equipped with sweeps having a 44 degree stem angle, sweep pitch varied from 0.5 to 3.5 degrees over the range of normal primary tillage draft, if the shank cushioning springs were at their maximum setting. At this setting, with 305 mm (12 in) spacing, shank cushioning spring preload was exceeded at drafts greater than 7 kN/m (544 lb/ft), occurring at the upper end of the primary tillage draft range.

Penetration was very good in all conditions. The CI 204 was very stable and did not skew appreciably. Skewing was never serious enough to affect weed kill. The CI 204 followed the contour of rolling land very well. Weed kill was very good providing sweeps with sufficient overlap were used. Furrow bottom ridging was only slight, as long as the shank cushioning springs were at their maximum setting. The CI 204 was capable of clearing most heavy trash, but in wet, heavy trash, plugging occurred next to the centre section wheels.

The CI 204 could be conveniently placed into transport position in less than five minutes. The 178 mm (7 in) sweep-to-ground clearance, in transport position was adequate. The CI 204 could be safely towed at speeds up to 16 km/h (10 mph). Caution had to be observed when towing on public roads due to large transport width. The test machine had a transport height of only 3.0 m (9.7 ft), permitting safe transport under power lines in the three prairie provinces. The 11.9 m wide model of the CI 204 has a transport height greater than some power lines.

Adequate adjustment was provided for both lateral and forward-aft levelling. Tillage depth was uniform across the width of the cultivator providing the frame had been properly levelled. When equipped with optional finishing harrows, hitch weight was negative, making hitching inconvenient.

Average draft for the 8.3 m (27 ft) wide test machine, in light primary tillage, at 8 km/h (5 mph) varied from 14 kN (3060 lb) at 50 mm (2 in) depth to 31 kN (6860 lb) at 125 mm (5 in) depth. In heavy primary tillage at 8 km/h (5 mph), average draft varied from 15 kN (3330 lb) at 50 mm (2 in) to 54 kN (12,160 lb) at 125 mm (5 in).

In light primary tillage, at 10 km/h (6.2 mph) and 75 mm (3 in) depth, a tractor with 100 kW (134 hp) maximum power take-off rating will have sufficient power reserve to operate the 8.3 m (27 ft) wide CI 204. In heavy primary tillage, at the same depth and speed, a 122 kW (164 hp) tractor is needed.

The CI 204 was equipped with wing transport locks and a master cylinder transport lock to aid in transport safety. The operator's manual was clear, concise and well illustrated.

Some mechanical problems occurred during the 377 hours of field operation. Seven shanks were bent and one was broken. Two hydraulic hoses failed and two welds failed.

### RECOMMENDATIONS

It is recommended that the manufacturer consider:

1. Modifying the shank holder assembly to increase sweep lift clearance.
2. Improving pre-delivery inspection and set-up procedures.
3. Providing some means of holding the hitch clevis in the horizontal position to facilitate one-man hitching.
4. Providing an optional rear jack stand to facilitate hitching when equipped with mounted finishing harrows.
5. Including suggested shank cushioning spring settings in the operator's manual.
6. Supplying a slow moving vehicle sign.
7. Working with the agricultural equipment industry to standardize hydraulic quick couplers and hydraulic hose fitting threads.
8. Working with the agricultural equipment industry to standardize shank and sweep stem angles and sweep fasteners.

Chief Engineer -- E. O. Nyborg

Senior Engineer -- L. G. Smith

### THE MANUFACTURER STATES THAT

With regard to recommendation number:

1. Increased sweep lift clearance will be considered for a new design.
2. Action has been taken to improve pre-delivery inspection and set-up procedures.
3. A simple way of holding the clevis up has been built into the clevis starting with 1978 production.
4. This will be considered for future production, but we suggest that when tractor hydraulics is available, levelling through the depth control system is not inconvenient.
5. Recommended cushioning spring settings will be added to the operator's manual.
6. A slow moving vehicle sign will be provided on future models.
7. We would cooperate with any standards set up in this area.
8. For new design, we will consider the ASAE standard of 49 degrees to 51 degrees.

### GENERAL DESCRIPTION

The CI 204 is a trailing, flexible, three-section heavy duty cultivator suitable for medium and heavy primary tillage operations. It is available in eight widths ranging from 4.0 to 11.9 m. The test machine was an 8.3 m model, with a 3.9 m centre frame and two 2.2 m wings. It was equipped with 27 spring cushioned shanks, laterally spaced at 305 mm, arranged in three rows on the wings and in four rows on the centre section.

The centre frame is carried on two tandem wheel sets, while each wing is supported by a single wheel. Tillage depth of the centre section is set with a master hydraulic cylinder, with stroke control, directly connected to a rockshaft. Slave cylinders, in series with the master cylinder, control each wing wheel. The wings fold into upright transport position with a single hydraulic cylinder. A tractor with dual remote hydraulic controls is needed to operate the CI 204.

Detailed specifications are given in APPENDIX I while FIGURE 1 shows the location of major components.

### SCOPE OF TEST

The CI 204 was operated in the field conditions shown in TABLE 1, for 377 hours, while cultivating about 2018 ha. It was evaluated for quality of work, ease of operation and adjustment, power requirements, safety and suitability of the operator's manual. Optional attached finishing harrows were used during most of the test.

## RESULTS AND DISCUSSION

### QUALITY OF WORK

**Shank Characteristics:** There is a large variation in shank and sweep stem angles (FIGURE 2) on cultivators from different

manufacturers. Sweeps and shanks must be matched to obtain sufficient sweep pitch to achieve and maintain penetration. Usually manufacturers recommend sweeps with a stem angle from 0 to 5 degrees less than the shank stem angle to result in a slightly positive no-load sweep pitch.

TABLE 1. Operating Conditions.

FIELD CONDITIONS	HOURS	FIELD AREA (ha)
Soil Type		
- loam	315	1673
- clay loam	55	303
- clay	7	42
TOTAL	377	2018
Stoney Phase		
- stone free	18	98
- occasional stones	168	872
- moderately stony	180	966
- vey stony	11	62
TOTAL	377	2018

Sweep pitch increases in proportion to draft due to shank flexing and, depending on shank stiffness and cushioning spring preload, may become excessive in normal tillage, on some cultivators. A slightly positive sweep pitch results in uniform tillage depth and a smooth furrow bottom while excessive sweep pitch causes furrow bottom ridging and rapid sweep tip wear. Shanks which maintain a relatively constant sweep pitch, over the normal range of tillage forces, are desirable.

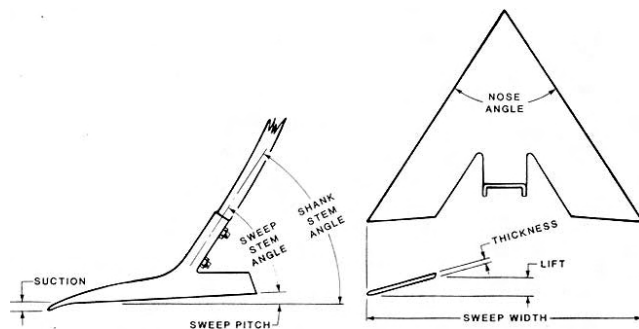

FIGURE 2. Shank and Sweep Terminology.

The CI 204 was equipped with adjustable spring cushioned shank holders. The spring tension could be adjusted over a wide range. No recommended settings were given in the operator's manual. During the test, the CI 204 was used with 406 mm wide CI sweeps with a 44 degree stem angle, giving a no load sweep pitch of 0.5 degrees.

FIGURE 3 shows pitch characteristics of the CI 204 shank assembly with the cushioning spring set at minimum and maximum positions. The low end of the pitch curve results from shank flexing, while the steeper upper part of the curve occurs when draft is large enough to overcome cushioning spring preload. At the minimum spring setting, sweep pitch varied by 10 degrees over the full range of draft occurring in primary tillage, while at the maximum spring setting, sweep pitch varied by only 3 degrees over the same draft range. When equipped with 44 degree sweeps, at maximum spring setting, sweep pitch varied from 0.5 degrees to 3.5 degrees over the full draft range. At the maximum spring settings, cushioning spring preload was exceeded at drafts greater than 7 kN/m, occurring at the upper end of the primary tillage draft range, indicating that the CI 204 was well suited for heavy primary tillage. It is recommended that the manufacturer include suggested cushioning spring settings in the operator's manual.

FIGURE 4 shows the lifting pattern when shanks encounter stones or field obstructions. Maximum lift height was 95 mm, since the shanks bottomed against mechanical stops. At maximum spring Settings, lift height was reduced due to the spring bottoming. Seven shanks were bent and one shank broke while operating in very stony fields. Shank bending was caused by the low lift height necessitating stones to be pulled out or the frame to lift to clear stones.

**Penetration:** Penetration was good in all conditions if the sweep tips were not excessively worn and if the shank cushioning

springs were properly adjusted.

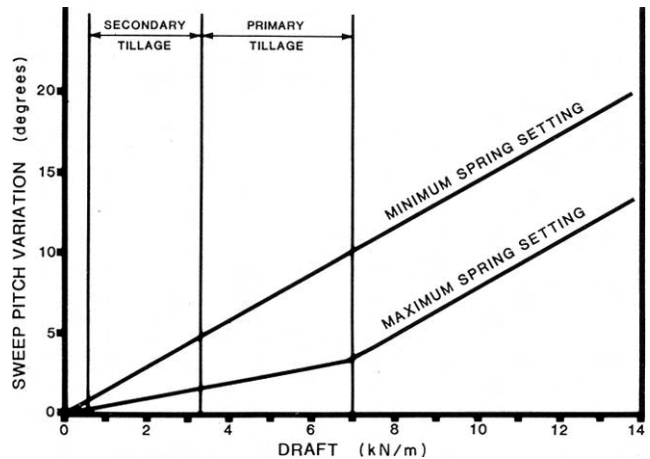

FIGURE 3. Sweep Pitch Variation over a Normal Range of Draft (305 mm shank spacing).

In most conditions, the CI 204 penetrated uniformly across its width. Tires were adequately sized to provide good flotation in most soil conditions. The wheels were positioned so that each centre section wheel supported about 18% of the cultivator weight while each wing wheel supported about 14%. In addition, each centre section wheel supported about 14% of the total tillage suction force while each wing wheel supported about 22%. For good flotation and uniform tillage depth across the cultivator width, it is desirable to have wheels sized and positioned so that each supports equivalent weight and similar tillage suction force.

Depth differences between the front and rear rows of shanks were slight, once the frame had been properly levelled. In all conditions, the frame remained relatively level with insignificant twisting of the wing frames.

The CI 204 followed gently rolling field contours well. The centre section was 3.9 m wide, while each wing was only 2.1 m wide resulting in fairly uniform penetration across the cultivator width, in rolling fields. As with most wing cultivators, large variations in tillage depth could occur in fields with abrupt contour changes.

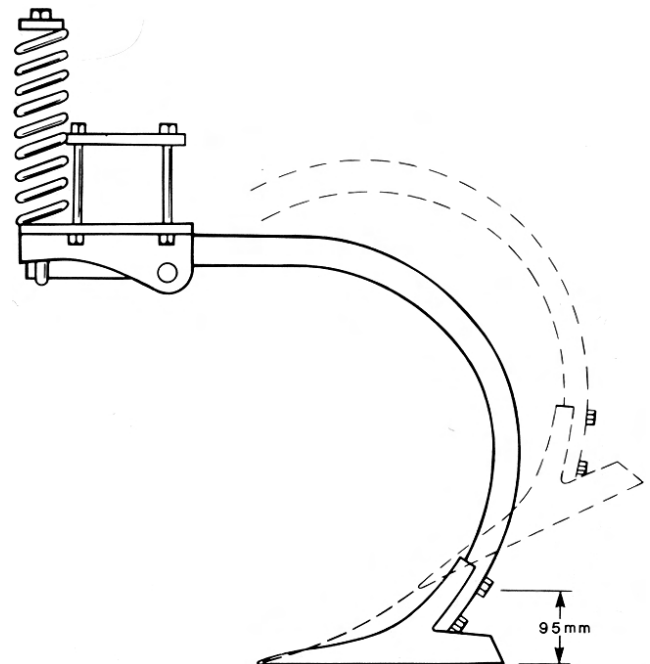

FIGURE 4. Shank Lifting Pattern.

**Plugging:** Trash clearance was very good. The CI 204 was capable of clearing large amounts of trash in normal conditions. Plugging occurred in heavy, damp straw or very heavy weed growth and usually began at the centre section wheels due to the limited clearance with the adjacent shanks.

The optional mounted finishing harrows contributed to plugging in loose heavy trash due to the short harrow mounting arm. If trash was not well anchored, the harrows bunched, leading to plugging. In anchored, moderately heavy trash, the harrows cleared trash reasonable well.

**Trash Burial and Surface Conditions:** With the shank cushioning springs at maximum setting, the CI 204 left most stubble standing upright, at 75 mm depth and speeds below 6 km/h. The amount of trash buried increased at speeds above 6 km/h and at depths greater than 75 mm. Trash burial increased appreciably at lower cushioning spring settings. In normal conditions, sufficient trash was usually buried in first operation summerfallow to allow the use of a field cultivator for the next operation.

Surface ridging varied from 25 to 50 mm with the cushioning springs at maximum setting. The C1204 produced a ridge on either side of the centre section, which mounted harrows usually could not completely level.

**Furrow Bottom Ridging:** In normal conditions, with the shank cushioning springs at maximum setting, furrow bottom ridging was less than 15 mm. Severe furrow bottom ridging could occur in harder soils at lower cushioning spring settings (FIGURE 3).

**Skewing and Stability:** The CI 204 was very stable and did not skew sideways in normal field conditions. The shank pattern (FIGURE 5) was symmetrical and did not impose any side forces on the cultivator during normal tillage. Slight sideways skewing occurred on hillsides, however skewing never was serious enough to cause weed misses. When equipped with 406 mm sweeps, the CI 204 would have to skew more than 3 degrees to miss weeds.

**Weed Kill:** Weed kill was good with 406 mm sweeps. The standard sweep spacing of 305 mm resulted in a 101 mm sweep overlap. Considerable sweep wear could occur before weeds were missed. Two of the centre section wheels travelled, on cultivated ground. In moist soil conditions, some weed transplanting could occur behind these wheels.

## EASE OF OPERATION AND ADJUSTMENT

**Transporting:** The CI 204 was easily placed in transport position (FIGURE 6) using the hydraulic wing lift system supplied as standard equipment. Pins were provided to lock the wings during transport and a locking arm was provided for the master hydraulic depth control cylinder. It took one man less than five minutes to place the CI 204 in transport position.



FIGURE 6 . Transport Position.

Transport width was 5.7 m while transport height was 3.0 m. Care was needed when transporting on public roads, through gates and over bridges.

Hitch weight, with mounted finishing harrows was minus 90 kg. Negative hitch weight caused cultivator swaying at higher transport speeds. If a farm truck is used to transport the cultivator, sufficient weight should be added to the truck to compensate for the negative hitch weight.

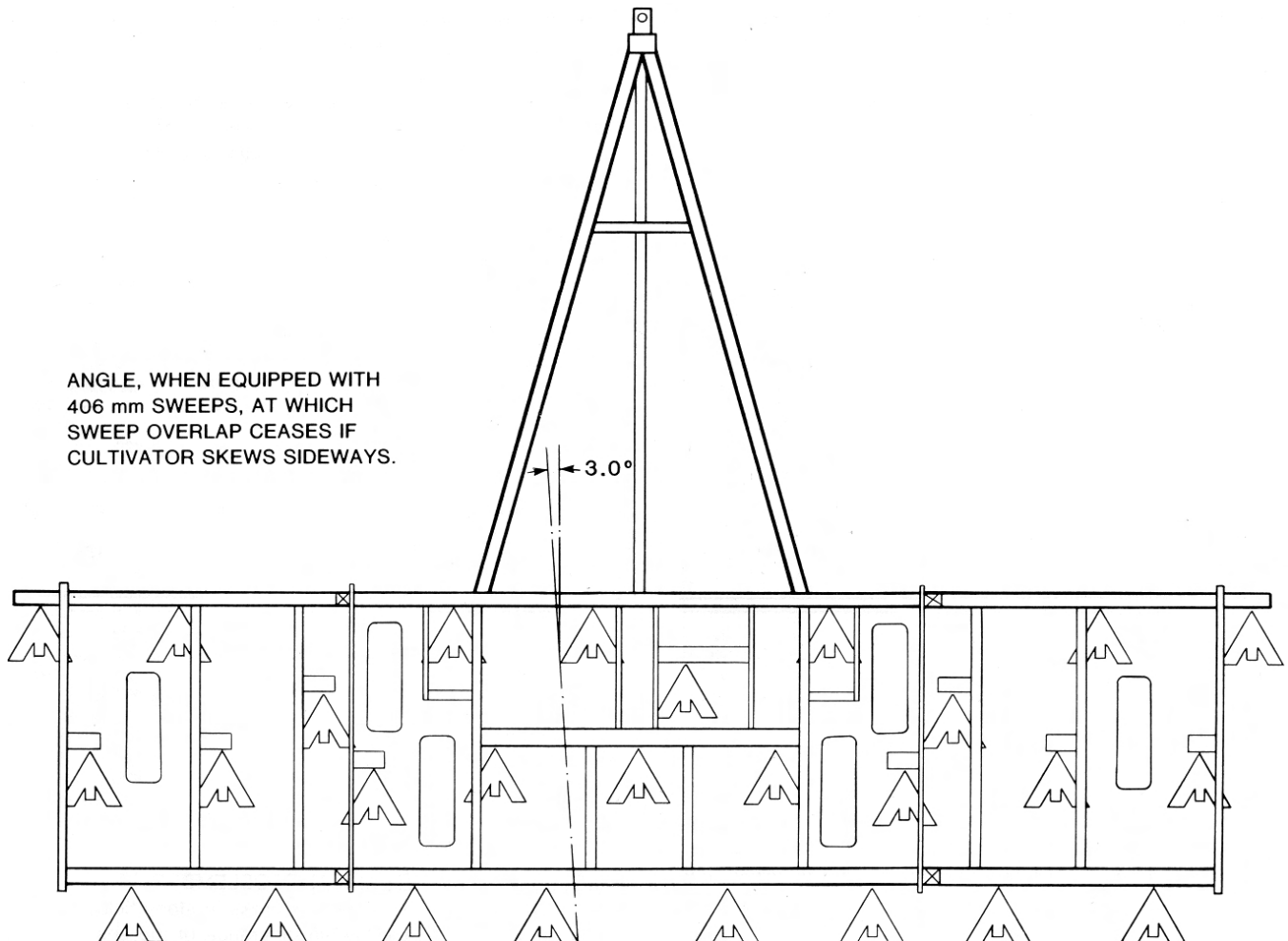

FIGURE 5. Sweep Pattern (305 mm Shank spacing).

Sweep to ground clearance during transport was 178 mm, while transport wheel tread was 3.0 m, providing ample ground clearance.

**Hitching:** The hitch weight of minus 90 kg made hitching difficult. The operator had to hook up the hydraulic hoses to lower the cultivator to tractor drawbar height. No optional jack stand for the rear of the cultivator was available.

The hitch clevis swivelled downward when not hitched to a tractor (FIGURE 7). One-man hitching would have been greatly facilitated if the clevis remained horizontal. It is recommended that the manufacturer modify the hitch clevis and supply an optional rear jack stand to facilitate easier hitching.

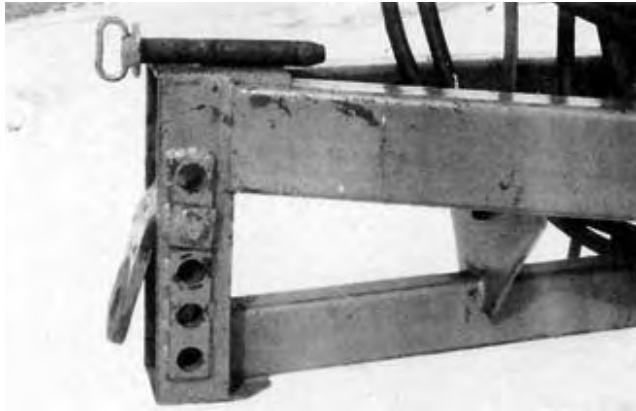

FIGURE 7. Hitch Clevis in Vertical Position.

The hitch height could be adjusted 228 mm in five increments by removing one bolt. This range was adequate to allow fore-and-aft frame levelling with all tractors used during the test.

**Frame Levelling:** Adequate lateral levelling adjustments were provided for both the centre and wing sections. The wing sections were levelled to centre section height by adjusting the rockshaft cylinder mounting brackets.

**Depth of Tillage:** Tillage depth is controlled with three hydraulic cylinders connected in series. The depth of the centre frame section is controlled with a master hydraulic cylinder with hydraulic stroke control. Slave cylinders, in series with the master cylinder, control each wing wheel. As is common with series hydraulic systems, to maintain the centre and wing frames at the same height, periodic synchronization of the cylinders, by extending them to the fully raised position, was necessary.

**Sweep Installation:** It took one man about one hour to remove and replace the 27 sweeps on the CI 204. The sweep bolts were shod enough to have their ends completely covered by the retaining nuts, preventing thread damage during tillage.

**Shank Installation:** Individual shanks could be easily replaced in about ten minutes by removing the spring U-bolt and loosening the shank U-bolt.

## POWER REQUIREMENTS

**Draft Characteristics:** FIGURE 8 shows draft requirements for heavy duty cultivators in typical primary tillage at a speed of 8 km/h. This figure gives average requirements based on tests of 10 makes of heavy duty cultivators in 40 different field conditions. Attempting to compare draft requirements of different makes of heavy duty cultivators usually is unrealistic. Draft requirements for the same cultivator, in the same field, may vary by as much as 30% in two different years, due to changes in soil conditions. Variation in soil conditions affect draft much more than variation in machine make, usually making it impossible to measure any significant draft differences between different makes of heavy duty cultivators.

In light primary tillage, average draft per metre of width, at 8 km/h, varied from 1.7 kN at 50 mm depth to 3.7 kN at 125 mm depth. For the 8.3 m wide CI 204, this corresponds to a total draft ranging from 14 to 31 kN.

In heavy primary tillage, average draft per metre of width, at 8 km/h, varied from 1.8 kN at 50 mm depth to 6.5 kN at 125 mm depth, corresponding to a total draft from about 15 to 54 kN for the 8.3 m test machine.

Increasing speed by 1 km/h, increased draft by about 90 N per metre of width. For the 8.3 m wide test machine, this represents a draft increase of 0.8 kN for a 1 km/h speed increase.

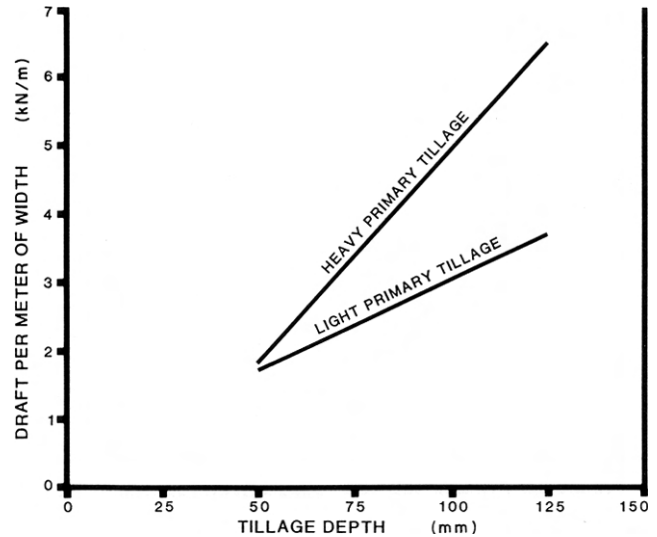

FIGURE 8. Average Draft Requirements for Heavy Duty Cultivators at 8 km/h.

**Tractor Size:** TABLES 2 and 3 show tractor sizes needed to operate the 8.3 m wide CI 204 in light and heavy primary tillage. Tractor sizes have been adjusted to include tractive efficiency and represent a tractor operating at 80% of maximum power on a level field. The sizes presented in the tables are the maximum power take-off rating, as determined by Nebraska tests or as presented by the tractor manufacturer. Selected tractor sizes will have ample power reserve to operate the CI 204 in the stated conditions.

Tractor size may be determined by selecting the desired tillage depth and speed from the appropriate table. For example, in light primary tillage at 75 mm depth and 10 km/h, a 100 kW tractor is needed to operate the CI. In heavy primary tillage, at the same depth and speed, a 122 kW tractor is needed.

TABLE 2. Tractor Size (Maximum Power Take-off Rating, kW) to Operate the 8.3 m wide CI 204 in Light Primary Tillage.

DEPTH mm	SPEED km/h					
	7	8	9	10	11	12
60	43	52	62	73	84	96
75	62	74	86	100	114	120
100	81	95	111	127	143	161
125	100	117	135	154	173	193

TABLE 3. Tractor Size (Maximum Power Take-off Rating, kW) to Operate the 8.3 m wide CI 204 in Heavy Primary Tillage.

DEPTH mm	SPEED km/h					
	7	8	9	10	11	12
50	41	49	58	68	78	90
75	78	92	107	122	138	154
100	116	135	155	178	197	219
125	154	179	204	230	257	284

## OPERATOR SAFETY

Extreme caution is needed in transporting most folding cultivators to avoid contacting power lines. Minimum power line heights vary in the three prairie provinces. In Saskatchewan, the energized line may be as low as 5.2 m over farm land or over secondary roads. In Alberta and Manitoba, the neutral ground wire may be as low as 4.8 m over farm land. In all three provinces, lines in farmyards may be as low as 4.6 m.

Transport height of the 8.3 m wide test machine was 3.0 m, permitting safe transport under prairie power lines. On the other hand, transport height of the 11.9 m wide model of the CI 204 is 4.8 m, which is high enough for contact with many prairie powerlines. The legal responsibility for safe passage under utility lines rests with the machinery operator and not with the power utility or the machinery manufacturer. All provinces have regulations governing maximum

permissible equipment heights on various types of public roads. If height limits are exceeded, the operator must contact power and telephone utilities before moving.

The CI 204 was 5.7 m wide in transport position. This necessitated caution when towing on public roads, over bridges and through gates. The CI 204 was equipped with an optional slow moving vehicle sign. It is recommended that a slow moving vehicle sign be supplied as standard equipment.

Pins were provided to lock the wings in transport position and a transport lock was provided for the centre frame lift cylinder. The four tires supporting the main frame were adequately sized to support the cultivator weight in transport position. The operator's manual clearly outlined safety precautions.

**STANDARDIZATION**

**Hydraulics:** During the test, considerable difficulty was encountered due to differences in hydraulic couplers on various tractors. The difficulty was in the lack of standardization both in couplers and in hose threads. More standardization is needed in this area.

**Sweep Bolt Holes:** The bolt hole size and spacing on cultivator sweeps and shanks, as well as stem angles, should similarly be standardized to provide some degree of interchangeability of sweeps.

**OPERATOR'S MANUAL**

The operator's manual contained useful information on safety, operation, maintenance and assembly. It was clear, concise, and well illustrated, but did not contain any suggested settings for the shank cushioning spring.

**DURABILITY RESULTS**

TABLE 4 outlines the mechanical history of the CI 204 during 377 hours of field operation while tilling about 2018 ha. The intent of the test was evaluation of functional performance. The following mechanical problems represent those which occurred during functional testing. An extended durability evaluation was not conducted.

TABLE 4. Mechanical History

ITEMS	OPERATING HOURS	EQUIVALENT FIELD AREA ha
Sweeps and Shanks		
- A shank bent and was replaced at	12,32,50,72,80,159,252	66,175,274,394,437,870,1377
- A shank broke and was replaced at	115	629
- Complete sets of worn sweeps were replaced at	57,170,252	322,929,1377
- A shank pin was lost at	57,170,252	322,929,1377
Frame		
- The main frame weld cracked and was re-welded at	252	1377
- The wing wheel rockshaft weld cracked and was re-welded at	80	437
Hydraulic Hoses		
- A hydraulic hose on a wing cylinder was replaced at	42	250
- A hydraulic hose on the main cylinder was replaced at	112	615

**DISCUSSION OF MECHANICAL PROBLEMS**

**Shanks:** Eight shanks bent or broke in stony fields. This was attributed mainly to the low lift clearance of the shank holders. Maximum shank lift height of 95 mm required that the entire cultivator lift or slide sideways to clear large rocks. It is recommended that the manufacturer modify the shank holders to increase shank lift height.

**Sweep Wear:** As is common with most cultivators, rapid, non-uniform wear occurred on the sweeps which followed the cultivator and tractor wheel tracks. Complete sweep sets needed replacement three times in 377 hours. Sweep wear rate depends on the type and abrasiveness of the soil. Great variation can be expected.

**Weld Failures:** Weld failures on the main frame and rockshaft were due to inadequate penetration of the factory welds. **Hydraulic Hoses:** Failure of the hydraulic hoses was due to poor crimping of the fitting to the hose.

**Predelivery:** When received, the cultivator had numerous loose bolts, improperly oriented hydraulic fittings, loose wheel bearings, uneven tension on the shank cushion springs and improper placement of wing lockup brackets. It is recommended

that the manufacturer improve predelivery inspection and set-up procedures.

**APPENDIX I**

**SPECIFICATIONS**

**MAKE:** Co-op Implements Heavy Duty Cultivator  
**MODEL:** 204 (8.3 m size)  
**SERIAL NUMBER:** NOV 75 8790  
**MANUFACTURER:** Canadian Co-operative Implements Limited  
 770 Pandora Avenue East  
 Winnipeg, Manitoba  
 R2C 3N1

<b>DIMENSIONS</b>	<b>FIELD</b>	<b>TRANSPORT</b>
	<b>POSITION</b>	<b>POSITION</b>
- width	8330 mm	5730 mm
	5995 mm	5995 mm
- height	1370 mm	2950 mm
- maximum ground clearance	178 mm	178 mm
- wheel tread	6860 mm	2470 mm

**SHANKS:**

- number	27
- latarsl spacing	305 mm
- trash clearance (frame to sweep tip)	610 mm
- number of shank rows	43
- distance between rows	953 mm
	32 x 51 mm
	44.5°
- sweep hole spacing	70 mm
- sweep bolt size	11 mm

**HITCH:**

- vertical adjustment range	229 mm
	hydraulic

**FRAME:**

102 mm, 6.4 mm thick, square tubing

**TIRES:**

- centre section	4, 7.60 x 15, 6 ply
	2, 7.60 x 15, 6 ply

**NUMBER OF LUBRICATION POINTS:**

16 grease fittings, daily service;  
 6 wheel bearings, annual service;  
 2 grease fittings, bi-weekly service

**HYDRAULIC CYLINDERS:**

- main frame, depth control master	1, 108 x 203 mm
- wings, depth control slave	1, 102 x 203 mm and 1, 95 x 203 mm
-- wing lift	1, 102 x 1219 mm

**WEIGHTS: (Without Harrows)**

	<b>FIELD POSITION</b>	<b>TRANSPORT POSITION</b>
- right wing wheel	400 kg	
- right centre wheels	1290 kg	1690 kg
- left centre wheel	1231 kg	1692 kg
- left wing wheel	461 kg	
- hitch	-90 kg	-90 kg
<b>TOTAL</b>	<b>3292 kg</b>	<b>3292 kg</b>

**OPTIONAL EQUIPMENT:**

- eight width options from 4.0 to 11.9 m

**APPENDIX II**

**MACHINE RATINGS**

The following rating scale 18 used in PAMI Evaluation Reports:

(a) excellent	(b) very good
(c) good	(d) fair
(e) poor	(e) unsatisfactory

**APPENDIX III**

**METRIC UNITS**

In keeping with the Canadian Metric Conversion program, this report has been prepared in S I units. For comparative purposes, the following conversions may be used:

1 hectare (ha)	= 2.47 acres (ac)
1 kilometre/hour (km/h)	= 0.62 mile/hour (mph)
1000 millimetres (mm) = 1 metre (m)	= 39.37 inches (in)
1 kilowatt (kW)	= 1.34 horsepower (hp)
1 kilogram (kg)	= 2.20 pounds mass (lb)
1 newton (N)	= 0.22 pounds force (lb)
1 kilonewton (kN)	= 220 pounds force (lb)
1 kilonewton/metre (kN/m)	= 70 pounds force/foot (lb/ft)



**ALBERTA  
 FARM  
 MACHINERY  
 RESEARCH  
 CENTRE**

3000 College Drive South  
 Lethbridge, Alberta, Canada T1K 1L6  
 Telephone: (403) 329-1212  
 FAX: (403) 329-5562  
<http://www.agric.gov.ab.ca/navigation/engineering/afmrc/index.html>

**Prairie Agricultural Machinery Institute**

Head Office: P.O. Box 1900, Humboldt, Saskatchewan, Canada S0K 2A0  
 Telephone: (306) 682-2555

Test Stations:

P.O. Box 1060  
 Portage la Prairie, Manitoba, Canada R1N 3C5  
 Telephone: (204) 239-5445  
 Fax: (204) 239-7124

P.O. Box 1150  
 Humboldt, Saskatchewan, Canada S0K 2A0  
 Telephone: (306) 682-5033  
 Fax: (306) 682-5080