

# Evaluation Report

# 568



## Cereal Implements Model 806 Chisel Plow

A Co-operative Program Between



# CEREAL IMPLEMENTS MODEL 806 CHISEL PLOW

## MANUFACTURER:

Vicon Western Canada  
1000 Sixth Avenue NE  
Portage la Prairie, Manitoba  
R1N 3R3  
Phone: (204) 239-5544

## RETAIL PRICE:

\$14,605.00 (August, 1988, f.o.b. Lethbridge, Alberta) containing

## DISTRIBUTOR:

Cereal Implements  
P.O. Box 3200 Portage la Prairie, Manitoba  
R1N 3R3

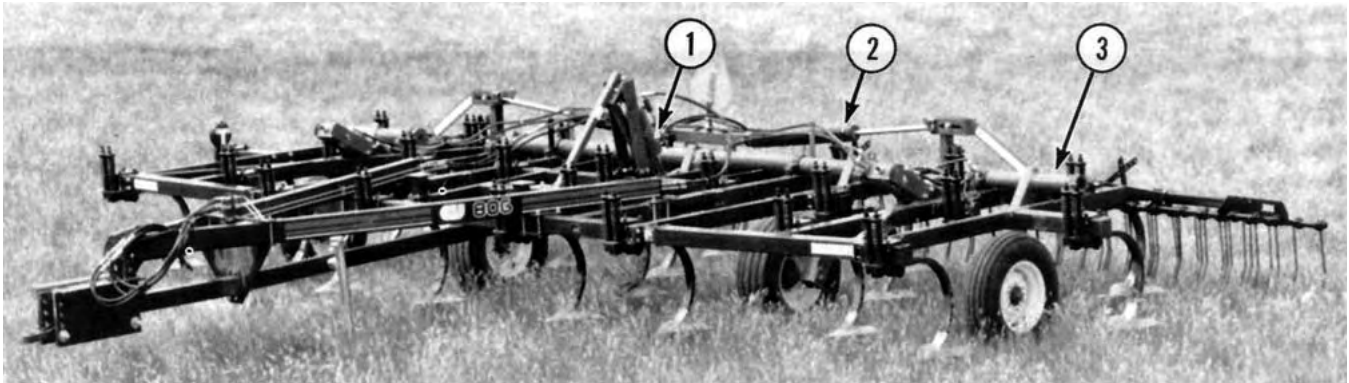

FIGURE 1. Cereal Implements Model 806 Chisel Plow: (1) Depth Control Cylinder, (2) Wing Lift Cylinder, (3) Rock Shaft.

## SUMMARY

**Quality of Work:** The Cereal Implements Model 806 heavy duty chisel plow was suitable for primary and secondary tillage. Penetration was very good with the 16 in (406 mm) sweeps at 12 in (305 mm) shank spacing. Depth uniformity was good. Laboratory testing of the Model 806 shank assembly showed it would maintain a uniform tillage or seeding depth while operating in primary and secondary conditions. The cultivator shank configuration allowed for overlap without running the wheel on cultivated soil.

The maximum lift height of the shank assembly was 5 in (127 mm) when equipped with 16 in (406 mm) sweeps. This lift height provided fair stone protection.

Trash clearance at the 12 in (305 mm) shank spacing was very good. In heavy, damp trash, plugging would occur at the wheel locations. With the optional harrows attached, the surface finish left by the CI 806 in light, loose trash was good. The harrows were not used in heavy trash conditions.

The Model 806 was stable but did skew in gently to moderately rolling field conditions. Weed kill was good with the 16 in (406 mm) sweeps at 12 in (305 mm) shank spacing.

**Ease of Operation and Adjustment:** Transporting the Model 806 chisel plow was very good. The hitch jack and rigid hitch link made one man hitching easy. If the optional harrows were attached, care had to be taken when disconnecting the chisel plow from the tractor, because negative hitch weight could occur. Ease of levelling the frame was very good. Vertical hitch adjustment was 14 in (356 mm) in six increments. The wing wheels could be adjusted separately for lateral levelling. Ease of setting the tillage depth was very good.

A mechanical stop on the main frame cylinder was adjusted to set the tillage depth.

Ease of setting the harrows was poor. Considerable time was required to adjust the height and pressure of the optional harrows.

**Power Requirements:** In secondary tillage at 3 in (75 mm) and 5 mph (8 km/h), a tractor with 108 (80 kW) PTO horsepower is required. At the same speed and depth in primary tillage a 120 hp (89 kW) PTO horsepower is required.

**Operator Safety:** Operation of the Model 806 chisel plow was good provided normal safety procedures were provided.

**Operator's Manual:** The operator's manual was very good, useful information on safety, assembly, adjustment, specifications, maintenance and operation. A detailed parts list was also included.

**Mechanical History:** Two shanks bent and the left rear hinge pin fell out during the evaluation.

## RECOMMENDATIONS

It is recommended that the manufacturer consider:

1. Modifying the shank assembly to reduce shank damage when operating in rocky conditions.
2. Balancing the chisel plow so that an operator can safely hitch and unhitch the unit from the tractor.
3. Modifying the height and pressure adjustment on the tine harrows to improve the setting time.
4. Supplying a safety chain as standard equipment in accordance with ASAE standards.

Station Manager: R. P. Atkins

Project Technologist: G. A. Magyar

## THE MANUFACTURER STATES THAT

With recommendation number:

1. The Company is presently taking steps to improve the strength of the shank, improve the trip height and also increase the trip force.
2. The balance of the chisel plow is neutral when equipped with C.I. tine harrows (which are of heavier construction than most). In subsequent operators manuals, the procedure for hitching and unhitching will be highlighted. The recommended procedure will be to have the weight of the machine resting upon the shovels prior to hitching or unhitching.
3. Modifications to the tine harrow adjustments are not planned at this time. Our present design has proven to be rugged and reliable and requires a minimum of adjustment.
4. The available safety chain and its use is described in both parts and operators manuals. It will be included as standard equipment in subsequent production.

## GENERAL DESCRIPTION

The Cereal Implements Model 806 Chisel Plow is a trailing, flexible, three section chisel plow suitable for primary and secondary tillage operations. The test machine is 25.3 ft (7.7 m) wide with a 12 ft (3.7 m) center frame and two 6.6 ft (2.0 m) wing sections. It has 25 spring cushion shanks arranged in three rows and spaced at 12 in (305 mm) intervals.

The center frame is supported by two wheels, while each wing frame is supported by a single wheel. Three hydraulic cylinders connected in series control tillage depth. The wings fold into transport position with two hydraulic cylinders connected in parallel. A tractor with dual remote hydraulic controls is needed to operate the Model 806 chisel plow. The test machine is equipped with optional three row tine harrows.

The Model 806 chisel plow is available in widths from 11 ft (3.4 m) to 25 ft (7.6 m). Detailed specifications are given in APPENDIX 1 while FIGURE 1 shows the location of major components.

## SCOPE OF TEST

The Cereal Implements Model 806 was tested during seeding in conjunction with Cereal Implements Model 1150 Air Seeder (Evaluation Report #565) and tillage operations in field conditions shown in TABLE 1, for approximately 61 hours while cultivating about 850 ac (344 ha). It was evaluated for quality of work, ease of operation and adjustment, power requirements, operator safety and suitability of the operator's manual.

TABLE 1. Operating Conditions.

FIELD CONDITIONS	HOURS	FIELD AREA	
		ac	ha
Operation			
- primary	33.0	330	133
- secondary	28.0	520	211
TOTAL	61.0	850	344
Soil Type			
- silt loam	20.5	240	97
- silty clay loam	15.5	210	85
- loam	25.0	400	162
TOTAL	61.0	850	344
Stony Phase			
- stone free	33.0	520	211
- occasional stones	11.0	130	52
- moderately stony	17.0	200	81
TOTAL	61.0	850	344

## RESULTS AND DISCUSSION

### QUALITY OF WORK

**Penetration:** Penetrating ability of the Model 806 chisel plow when equipped with 16 in (406 mm) sweeps was very good in all field conditions encountered.

Penetration was uniform across the cultivator width provided all depth linkages and the hitch height were kept properly adjusted. The narrow width of the wings prevented their frames from twisting. As with most rigid hitch cultivators, variations in tillage depth would occur in fields with abrupt contour changes.

Tillage depth required checking and appropriate adjustments when changing fields to ensure uniform penetration of the Model 806.

**Depth Uniformity:** Flexibility of the chisel plow frame and shank characteristics (FIGURE 2) determine depth uniformity of the sweep. Width of the centre and wing sections and how they are linked together determine how well the unit follows the contours of the field. Shank stiffness and cushion spring preload may cause sweep pitch to become excessive, resulting in furrow bottom ridging, rapid sweep tip wear and increased draft. A shank which maintains a low, relatively constant sweep pitch over the normal range of tillage forces was desirable. PAMI has selected seven degrees as a maximum operating steep pitch that will provide an acceptable furrow bottom for most operations.

Depth uniformity of the Model 806 was very good in both primary and secondary tillage conditions. The chisel plow followed rolling contours very well, maintaining uniform depth across the width. There was some variability when crossing gulleys or over sharp hill crests.

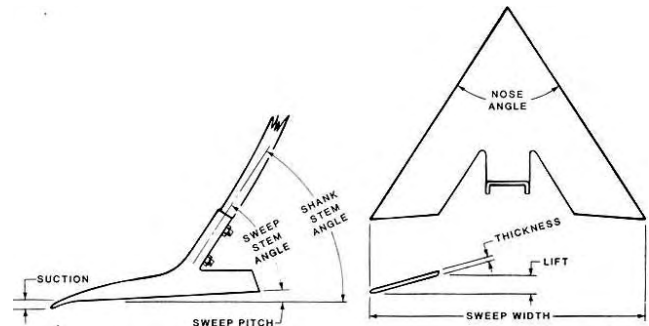

FIGURE 2. Shank and Sweep Terminology.

The sweep pitch characteristics of the Model 806 are shown in FIGURE 3. The no-load sweep pitch was 2 degrees. The lower sloped line shows how an increase in force gradually flexed the shank as indicated by a slight increase in sweep pitch. At a horizontal force of 500 lb (2.2 kN), the shank began to trip as the cushion-spring preload was overcome. This is the point on the curve where the steep upper curve begins. At a horizontal trip force of 680 lb (3.0 kN), the sweep pitch curve exceeded 7 degrees. This is the point where the steep curve crosses the broken horizontal line. The curve above the broken line shows how shank force increases as the shank trips over an obstacle.

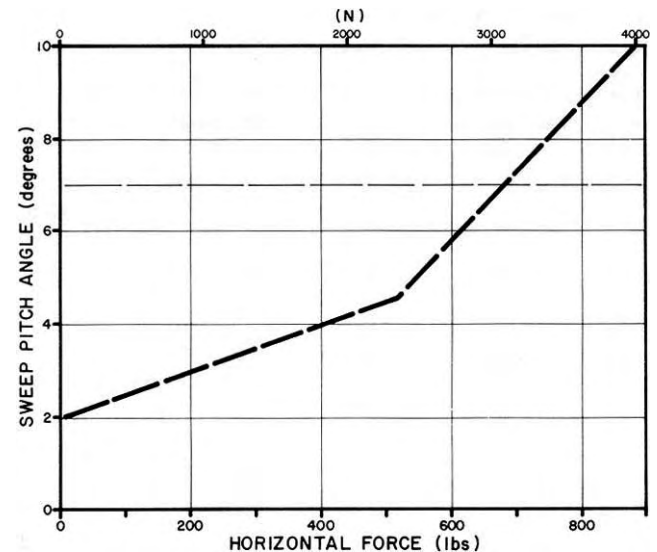

FIGURE 3. Sweep Pitch for CI 806 Shank.

Performance of the Model 806 can be determined by comparing its sweep pitch characteristics to the actual horizontal force that the shanks will encounter in the field. Research has been conducted to determine the typical prairie soil forces acting on soil tools located in the front row of a cultivator while operating at different depths in primary and secondary tillage (APPENDIX II). The position and subsequent performance of the soil tools can be predicted by comparing the researched soil forces to the counteracting shank force (FIGURE 3) developed by the shank assembly.

The Model 806 shank force at a 7 degree sweep pitch was greater than all shown soil forces. This indicated that the 12 and 16 in (305 and 406 mm) sweeps will maintain a uniform tillage or seeding depth while operating in primary and secondary tillage. The Model 806 would also maintain 2 in (50 mm) spikes and banding knives at uniform working depth in primary and secondary conditions. This would minimize shank assembly wear as the soil forces would not be causing partial tripping or continuous movement of the assembly.

The cultivator shank configuration allowed for half a sweep overlap without running the wheel on cultivated soil. Running all wheels on untilled soil helps maintain uniform tillage depth.

**Stone Protection:** Stone protection was fair. FIGURE 4 shows the lifting pattern when shanks encounter stones or field obstructions. A lift height of 12 in (300 mm) normally prevents shank and sweep damage in fields with large rocks. The maximum lift height of the CI 806 shank assembly was 5 in (127 mm) when equipped with

16 in (406 mm) sweeps. Two shanks bent while operating in stony fields. It is recommended the manufacturer consider modifying the shank assembly to reduce shank damage when operating in rocky conditions.

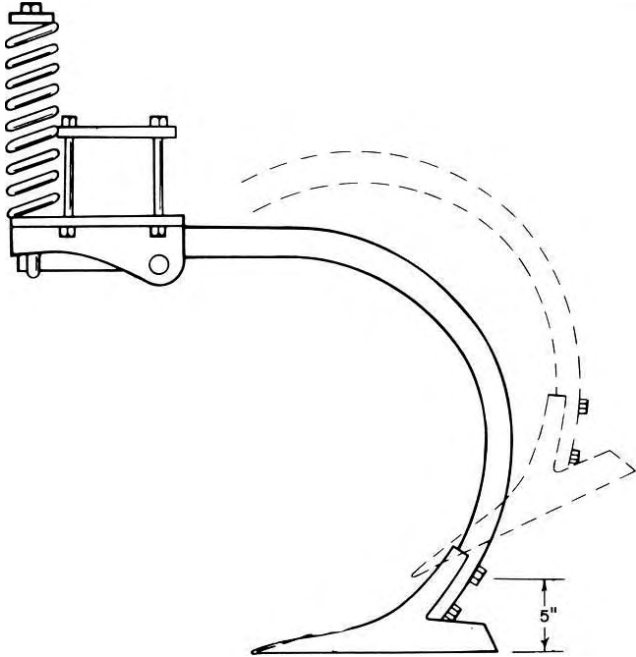

FIGURE 4. Shank Lifting Pattern.

**Trash Clearance:** The trash clearance of the 12 in (305 mm) shank spacing heavy duty chisel plow was very good.

The 12 in (305 mm) lateral shank spacing and 24 in (610 mm) sweep-to-frame clearance was suitable for clearing large amounts of dry trash. In heavy, damp trash, plugging usually occurred at the wheel locations.

**Surface Finish:** The field surface finish was good with the Model 806 heavy duty chisel plow. In moderate trash conditions, the optional harrows were effective in distributing the trash evenly when properly adjusted. In heavy trash, the harrows were placed into transport position to eliminate plugging. In light trash, the harrows were effective in levelling the ridges left by the chisel plow to produce a uniform seedbed.

**Skewing and Stability:** The Model 806 was stable and did not skew in typical field conditions. The sweep pattern (FIGURE 5) was symmetrical and did not impose any side forces on the chisel plow during tillage. Skewing was minimal even on hillsides or where soil hardness varied across the machine width. With the 16 in (406 mm) sweeps, the chisel plow had to skew more than 2.5 degrees for weed misses to occur.

**Weed Kill:** Weed kill was good with the 16 in (406 mm) sweeps and 12 in (305 mm) shank spacing. Effective weed kill depends on soil and moisture conditions and the stage of weed growth. The finishing harrows were effective in exposing weeds in light trash conditions.

#### EASE OF OPERATION AND ADJUSTMENT

**Maintenance:** Lubrication was convenient, with good access to all grease fittings. The rocker shaft bearings and wing hinges required greasing daily. The wheel bearing required annual servicing.

**Transporting:** Ease of transporting the Model 806 was good.

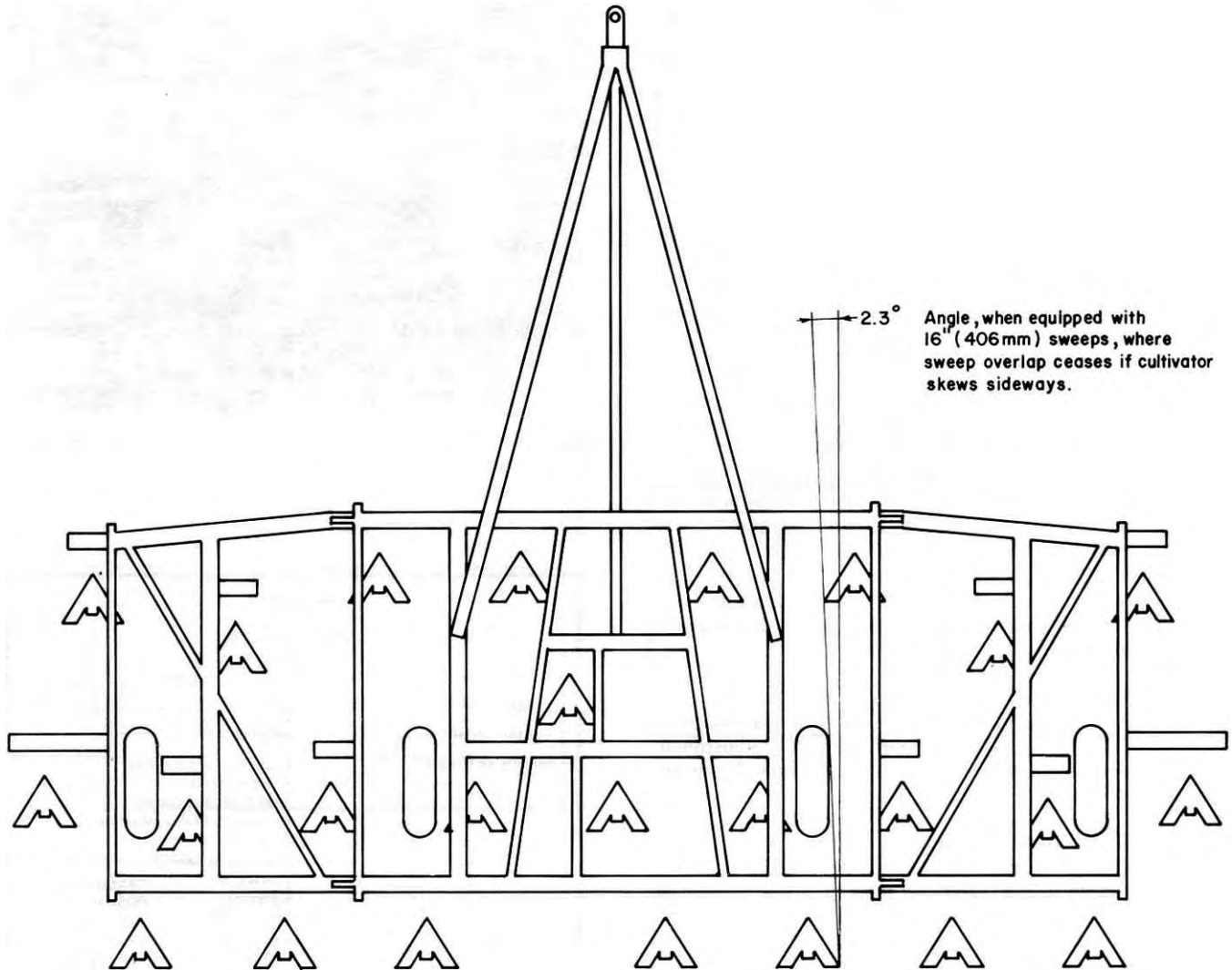

FIGURE 5. Sweep Pattern.

The hitch jack and rigid hitch link made one man hitching easy. Care had to be taken when disconnecting the chisel plow from the tractor because of the negative hitch weight due to the optional tine harrows. It is recommended that the manufacturer consider balancing the cultivator by providing a rear jack or added hitch weight at front so an operator can safely hitch and unhitch the unit from the tractor.

The Model 806 was easily placed in transport position by one person in less than five minutes (FIGURE 6). Locks were provided for the wings and the center frame wheels. Wing transport locks were located at the rear of the chisel plow, while the center frame transport lock was located on the depth cylinder. All locks could be positioned without climbing on the chisel plow. The optional harrows could be individually locked in a raised position for greater ground clearance during transport.

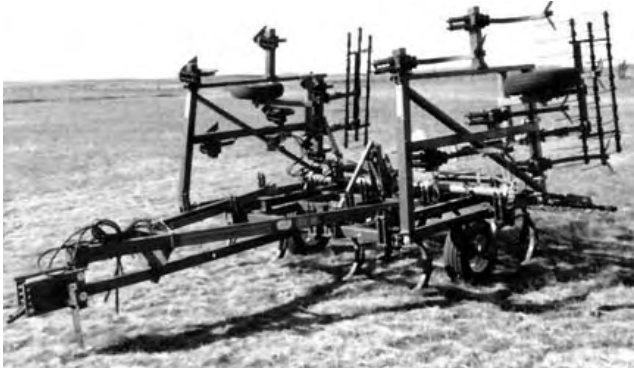

FIGURE 6. Transport Position.

Transport width of the test machine was 16.3 ft (5.0 m), while transport height was 10.1 ft (3.1 m). Normal care was needed when transporting on public roads, through gates, over bridges and beneath power lines.

Sufficient clearance between the tractor rear tires and the chisel plow hitch allowed for sharp turns in both field and transport positions.

The Model 806 towed well without sway or bounce at normal transport speed. A sweep-to-ground clearance of 6.3 in (160 mm) was sufficient.

**Frame Levelling:** Ease of levelling the frame was very good. Each wing levelling was accomplished by loosening the jam nut on the cylinder anchor and then adjusting the bolt length until the wings were level with the main frame. Front-to-back levelling was accomplished by adjusting the hitch height. Hitch height could be adjusted 14 in (356 mm) in six increments by removing one bolt. This range was adequate to allow front-to-back frame levelling with all tractors used during the test.

**Depth Adjustment:** Ease of setting the tillage depth was very good. Tillage depth was controlled with three hydraulic cylinders connected in series one on the center section and one on each wing section. A mechanical stop on the center frame cylinder was adjusted to set tillage depth. To ensure uniform tillage depth, the hydraulic cylinders had to be synchronized periodically by completely extending them to a fully raised position.

**Harrow Adjustment:** Ease of adjusting the optional tine harrows was poor. The harrow frame was levelled by loosening two bolts and then rotating the harrow gang on the cross tube until the harrows were level with the chisel plow frame. The tine angle could be adjusted to seven different positions. Height and pressure adjustment required loosening the carriage bolt and adjusting the nuts on the adjusting clevis (FIGURE 7). It took the operator approximately one hour to adjust the seven tine harrows. It is recommended that the manufacturer consider modifying the height and pressure adjustment to improve operator convenience.

## POWER REQUIREMENTS

PAMI has measured power requirements on several cultivators in various field conditions as explained in APPENDIX III. From these field measurements, average power requirements have been determined to assist farmers in matching tractor and cultivator sizes. The tractor sizes (TABLE 2) have been adjusted to include tractive efficiency and represent a tractor operating at 80 percent of its

maximum power take-off rating.

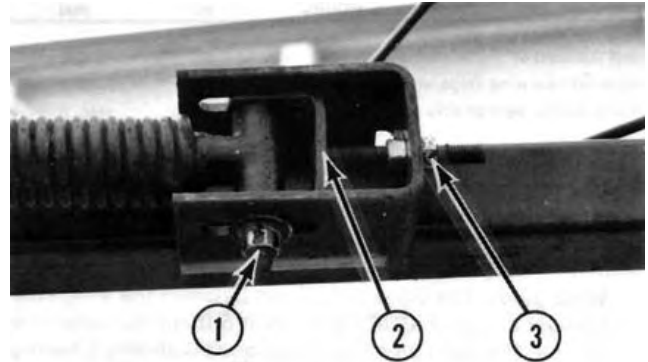

FIGURE 7. Harrow Tine Adjustment: (1) Carriage Bolt, (2) Adjusting Clevis, (3) Nuts.

TABLE 2. Tractor Size: PTO Power (hp(kW)) Required to Operate the 25.3 ft (7.7 m) Model 806 Heavy Duty Chisel Plow.

OPERATION	DEPTH in (mm)	SPEED - mph ( km/h)	
		5.0 (8.0)	6.0 (9.7)
PRIMARY	3.0 (75)	120 (90)	145 (109)
	4.0 (100)	153 (115)	185 (139)
SECONDARY	3.0 (75)	108 (81)	130 (98)
	4.0 (100)	142 (106)	170 (128)

In typical secondary tillage conditions at a speed of 5 mph (8 km/h) and a depth of 3 in (75 mm), average cultivator power requirements for the Model 806 was 108 hp (81 kW). The average power requirements at the same speed and depth in primary tillage was 120 hp (90 kW). Additional power will be required when tilling deeper or working in hilly terrain.

## OPERATOR SAFETY

The Model 806 chisel plow was 16.1 ft (5.0 m) wide in transport, which necessitated caution when towing on public roads, over bridges and through gates. A slow moving vehicle sign was provided as standard equipment, while the safety chain was supplied as an option. It is recommended that the manufacturer consider supplying the safety chain as standard equipment in accordance with the American Society of Agricultural Engineers' safety standards.

When in transport position with harrows attached, the load on the center section tires did not exceed the Tire and Rim Association's maximum load rating.

## OPERATOR'S MANUAL

The operator's manual for the CI Model 806 was very good. It contained useful information on safety, assembly, adjustment, specifications, maintenance and operation. A detailed parts list was also included.

## MECHANICAL HISTORY

TABLE 3 outlines the mechanical history of the Model 806 chisel plow during 61 hours of field operation while cultivating 850 ac (344 ha). The intent of the test was evaluation of functional performance. An extended durability evaluation was not conducted.

TABLE 3. Mechanical History

ITEM	OPERATING HOURS	EQUIVALENT FIELD AREA	
		ac	(ha)
- Rear left hinge pin was lost and replaced at	5	75	(30)
- Installed new wing stops at	17	250	(101)
- Replaced two bent shanks at	25, 36	360, 515	(146, 209)

**Shanks:** Three shanks bent while operating in rocky field conditions. Insufficient lift height was the probable cause for the shank damage. Modifications have already been recommended.

**Wing Stops:** The close tolerances between the wing stop and cylinder mount (FIGURE 8) made it difficult to install the safety pins. The wing stops were replaced with stops having a slotted hole, thus allowing for easier installation of the safety pins for transport

position. No further problems were encountered.

**Hinge Pin:** The left rear hinge pin worked itself loose and fell out. The new pin was double nutted and no further problems were encountered.

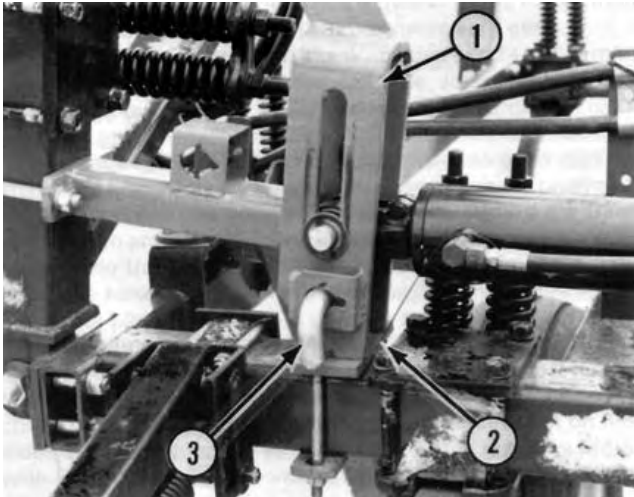

**FIGURE 8.** Wing Lock Assembly: (1) Cylinder Mount, (2) Wing Stop, (3) Safety Pin.

**APPENDIX I**

**SPECIFICATIONS**

**MAKE:** Cereal Implements  
**MODEL:** 806  
**SERIAL NUMBER:** 66009-00008  
**MANUFACTURER:** Vicon Western Canada  
 P.O. Box 3200  
 1000 Sixth Avenue NE  
 Portage la Prairie, Manitoba  
 R1N 3R3  
 Phone (204) 239-7011

DIMENSIONS:	FIELD	TRANSPORT
	POSITION	POSITION
- width	25.6 ft ( 7.8 m)	16.3 ft (5.0 m)
- length	19.9 ft ( 6.1 m)	19.9 ft (6.1 m)
- height	5.3 ft ( 1.6 m)	10.1 ft (3.1 m)
- maximum ground clearance	6.3 in (160 mm)	6.3 in (160 mm)
- maximum wheel tread	20.7 ft ( 6.3 m)	9.3 ft (2.8 m)

**SHANKS:**

- number 25
- lateral spacing 12 in (305 mm)
- trash clearance 24 in (610 mm)
- number of shank rows
  - center 3
  - wings 3
- distance between rows
  - center 34 in (864 mm)
  - wings Varied
- cross section 1.25 x 2 in (32 x 51 mm)
- stem angle 45 degrees
- sweep hole spacing 2.5 in (64 mm)
- sweep bolt size 0.5 in (13 mm)

**HITCH:**

- vertical range adjustment 14 in (360 mm) in 2.36 in (60 mm) increments

**DEPTH CONTROL:** Series Hydraulic

**FRAME:**

- main cross section 4 in (102 mm) square tubing
- wing cross section 2 x 4 in (51 x 102 mm) tubing

**TIRES:**

- center section Two, 11L - 15, 8 ply
- wing sections Two, 7.6 - 15, 4 ply

**NUMBER OF LUBRICATION POINTS:**

- grease fittings 13
- wheel bearings 4

**HYDRAULIC CYLINDERS:**

- depth control One, 4.25 x 8 in (108 x 204 mm)  
 One, 4.0 x 8 in (102 x 204 mm)  
 One, 3.75 x 8 in (95 x 204 mm)
- wing lift One, 3.5 x 8 in (89 x 711 mm)

WEIGHTS: (without harrows)	FIELD	TRANSPORT
	POSITION	POSITION
- hitch	320 lb (145 kg)	480 lb (218 kg)
- right wheel	910 lb (414 kg)	
- right center	1620 lb (736 kg)	2480 lb (1128 kg)
- left center	1680 lb (764 kg)	2509 lb (1136 kg)
- left wheel	930 lb (423 kg)	
TOTAL	5460 lb (2482 kg)	5460 lb (2482 kg)

**OPTIONAL EQUIPMENT AVAILABLE:**

- 8 width options from 11 to 25 ft (3.4 to 7.6 m)
- 5 to 7 ft (1.5 to 2.1 m) width three row mounted harrows, optional transport lock and lift kit available for harrows

**APPENDIX II**

**SOIL FORCE TABLES**

The following tables give typical horizontal forces acting on sweeps, spikes, and banding knives located in the front row of a cultivator while operating at different depths in primary and secondary tillage on the prairies Higher forces may be encountered in extremely heavy, dry or compacted soils

These values can be used to determine how well the shank assemblies are suited to the various operations Comparing the sweep pitch curve of the assembly to these soil forces will indicate whether the assembly will hold the soil tool below the acceptable 7 degree sweep pitch

**TABLE 4.** Forces Required (lb (kN)) in Primary Tillage for Various Soil Tools

DEPTH in (mm)	SWEEPS			SPIKE	BANDING KNIFE
	FIELD CULT	HEAVY DUTY CULT			
	11 in (275 mm)	12 in (305 mm)	16 in (406 mm)		
	lb (kN)	lb (kN)	lb (kN)	lb (kN)	lb (kN)
2 (50)	120 (0.5)	190 (0.8)	220 (1.0)	-	-
3 (75)	140 (0.6)	230 (1.0)	280 (1.2)	150 (0.7)	-
4 (100)	180 (0.8)	310 (1.4)	370 (1.6)	190 (0.8)	320 (1.4)
5 (125)	-	420 (1.9)	500 (2.2)	260 (1.2)	390 (1.7)
6 (150)	-	-	-	360 (1.6)	540 (2.4)

**TABLE 5.** Forces Required (lb (kN)) in Secondary Tillage for Various Soil Tools

DEPTH in (mm)	SWEEPS			SPIKE	BANDING KNIFE
	FIELD CULT	HEAVY DUTY CULT			
	11 in (275 mm)	12 in (305 mm)	16 in (406 mm)		
	lb (kN)	lb (kN)	lb (kN)	lb (kN)	lb (kN)
2 (50)	110 (0.5)	170 (0.8)	200 (0.9)	-	-
3 (75)	140 (0.6)	220 (1.0)	270 (1.2)	130 (0.6)	-
4 (100)	170 (0.8)	280 (1.2)	340 (1.5)	180 (0.8)	290 (1.3)
5 (125)	-	370 (1.6)	450 (2.0)	290 (1.1)	380 (1.7)
6 (150)	-	-	-	320 (1.4)	490 (2.2)

**APPENDIX III**

**POWER REQUIREMENTS**

**Draft Characteristics:** Draft requirements have been treasured on several cultivators in various field conditions over the past years Average draft requirements have been determined from these requirements

Draft requirements for the same cultivator, in the same field, may vary by as much as 30% in two different years due to changes in soil conditions Variations in soil conditions affect draft much more than variations in machine make, making it difficult to measure any significant draft differences between make of cultivators

Since there is little or no draft differences between machines, PAMI has averaged the results obtained over the years and has used these to determine tractor size requirements

**Recommended Tractor Size:** The following tables show tractor PTO power required to pull cultivators in various conditions at the given depths and speeds Tractor power requirements have been adjusted to include a tractive efficiency of 80% in primary and 70% in secondary tillage and represent a tractor operating at 80% of maximum PTO power on a level field These power requirements can be used along with the maximum PTO ratings, as determined by Nebraska tests or as presented by the tractor manufacturer, to select the appropriate tractor Higher power will be required in hills or in heavy soils Cultivators with marked differences in spacing, number of rows, or configuration may require more or less power

Recommended tractor size may be determined by selecting the required horsepower per foot from the appropriate table and multiplying by the width of the cultivator For example, in primary tillage at 4 in (100 mm) and 5 mph (8 km/h) 61 hp/ft (14.9 kW/m) is required Therefore, for a 41.3 ft (12.5 m) cultivator in those conditions, 250 PTO hp (185 kW) is recommended

**TABLE 6.** Tractor PTO Power Per Unit Width (hp/ft (kW/m)) Required in Primary Tillage

DEPTH in (mm)	SPEED - mph (km/h)		
	4.0 (6.4)	5.0 (8.0)	6.0 (9.7)
2 (50)	2.7 (6.6)	3.4 (8.3)	4.1 (10.0)
3 (75)	3.8 (9.3)	4.8 (11.7)	5.8 (14.2)
4 (100)	4.9 (12.0)	6.1 (14.9)	7.4 (18.1)
5 (125)	6.0 (14.7)	7.5 (18.4)	9.0 (22.0)

**TABLE 7.** Tractor PTO Power Per Unit Width (hp/ft (kW/m)) Required in Secondary Tillage

DEPTH in (mm)	SPEED - mph (km/h)		
	4.0 (6.4)	5.0 (8.0)	6.0 (9.7)
2 (50)	2.3 (5.6)	3.0 (7.3)	3.6 (8.8)
3 (75)	3.4 (8.3)	4.3 (10.5)	5.2 (12.7)
4 (100)	4.5 (11.0)	5.6 (13.7)	6.8 (16.6)
5 (125)	5.5 (13.5)	7.0 (17.1)	8.4 (20.6)

**APPENDIX IV**

**MACHINE RATINGS**

The following rating scale is used in PAMI Evaluation Reports:

- |           |                |
|-----------|----------------|
| Excellent | Very Good      |
| Good      | Fair           |
| Poor      | Unsatisfactory |

## SUMMARY CHART

### CEREAL IMPLEMENTS MODEL 806 CHISEL PLOW

<b>RETAIL PRICE:</b>	\$14,605.00 (August, 1988 f.o.b. Lethbridge 25.3 ft (7.7 m) width, optional harrows and sweeps.
<b>QUALITY OF WORK:</b>	
Penetration	<b>Very Good;</b> could be set to provide level furrow bottom in secondary and primary conditions.
Depth Uniformity	<b>Good</b>
Stone Protection	<b>Fair;</b> trip height was 5 in (127 mm)
Trash Clearance	<b>Very Good;</b> would plug in heavy damp trash
Surface Finish	<b>Good</b>
Weed Kill	<b>Good</b>
<b>EASE OF OPERATION AND ADJUSTMENT:</b>	
Transporting	<b>Good;</b> negative hitch weight could occur when harrows were attached
Frame Levelling	<b>Very Good</b>
Depth Adjustment	<b>Very Good</b>
Harrow Adjustment	<b>Poor;</b> time consuming when adjusting height and pressure of harrows
<b>POWER REQUIREMENTS:</b>	
Secondary Tillage	108 hp (80 kW) at 3 in (75 mm) and 5 mph (8 km/h)
Primary Tillage	120 hp (89 kW) at 3 in (75 mm) and 5 mph (8 km/h)
<b>OPERATOR SAFETY:</b>	Safe; if normal safety procedures were observed.
<b>OPERATOR'S MANUAL:</b>	<b>Very Good;</b> well written and clearly illustrated.
<b>MECHANICAL HISTORY:</b>	Two shanks were bent and the left wing hinge pin was lost.



3000 College Drive South  
Lethbridge, Alberta, Canada T1K 1L6  
Telephone: (403) 329-1212  
FAX: (403) 329-5562  
<http://www.agric.gov.ab.ca/navigation/engineering/afmrc/index.html>

#### Prairie Agricultural Machinery Institute

Head Office: P.O. Box 1900, Humboldt, Saskatchewan, Canada S0K 2A0  
Telephone: (306) 682-2555

Test Stations:  
P.O. Box 1060  
Portage la Prairie, Manitoba, Canada R1N 3C5  
Telephone: (204) 239-5445  
Fax: (204) 239-7124

P.O. Box 1150  
Humboldt, Saskatchewan, Canada S0K 2A0  
Telephone: (306) 682-5033  
Fax: (306) 682-5080