

# Evaluation Report

# 566



**Flexi-coil 600 Chisel Plow**

A Co-operative Program Between



# FLEXI-COIL 600 CHISEL PLOW

## MANUFACTURER AND DISTRIBUTOR:

Flexi-coil  
1000 71 Street E.  
P.O. Box 1928  
Saskatoon, Saskatchewan  
S7K 3S5  
Telephone: (306) 934-3500

## RETAIL PRICE:

\$28,760.00 (July, 1988, f.o.b. Lethbridge, Alberta, 36 ft (11 m) width complete with 3-bar mounted harrows and setup.)

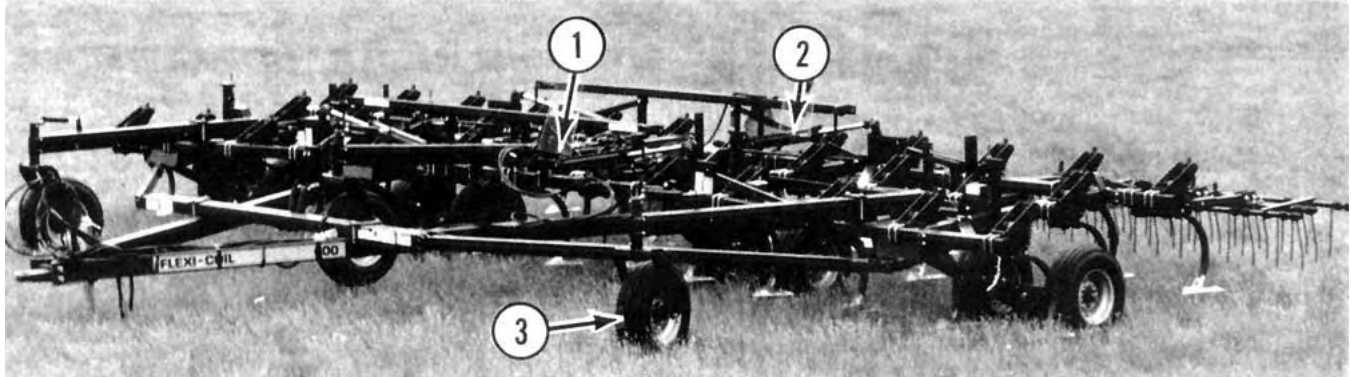

FIGURE 1. Flexi-coil 600: (1) Depth Control Cylinder, (2) Wing Lift Cylinders, (3) Outrigger Wheels

### SUMMARY OF RESULTS

**Quality of Work:** The Flexi-coil 600 heavy duty chisel plow was suitable for primary and secondary tillage. Penetration was very good with the 16 in (406 mm) sweeps at 11.6 in (300 mm) shank spacing. Depth uniformity was very good. Laboratory testing of the Flexi-coil shank assembly showed it would maintain a uniform tillage or seeding depth while operating in primary and secondary tillage.

The maximum lift height of the shank assembly was 13 in (330 mm) when equipped with 16 in (406 mm) sweeps. This lift height provided very good stone protection.

Trash clearance at the 11.6 in (300 mm) shank spacing was very good. In heavy, damp trash, plugging would occur at the wheel locations or between the front center shank and the left front shank. Plugging between the two shanks was caused by the narrow lateral spacing between the shanks. With the optional harrows attached, the surface finish left by the Flexi-coil 600 in light loose trash was good. The harrows were not used in heavy trash conditions.

The Flexi-coil 600 was stable but did skew in gently to moderately rolling field conditions. This did not affect the overall performance of the unit.

**Ease of Operation and Adjustment:** Ease of maintenance was very good. Transporting the Flexi-coil 600 heavy duty chisel plow was very good. The hitch jack and rigid hitch link made one man hitching easy. If the optional harrows were attached, positive hitch weight was still maintained.

Ease of levelling the frame was good. The floating hitch eliminated the need to level the hitch. Adequate adjustment was provided for front-to-back frame levelling and lateral levelling of the wings. Ease of setting the tillage depth was very good. A depth stop plunger was adjusted to set the tillage depth. Ease of setting the optional harrows was very good.

**Power Requirements:** In secondary tillage at 3 in (75 mm) and 5 mph (8 km/h), a tractor with 155 hp (115 kW) PTO horsepower is required. At the same speed and depth in primary tillage, a 173 hp (129 kW) PTO horsepower is required.

**Operator Safety:** Operation of the Flexi-coil 600 heavy duty chisel plow was safe provided normal safety procedures were observed. There was no safety chain supplied for on-road transportation.

**Operator's Manual:** The operator's manual was very good, containing useful information on safety, assembly, adjustment, specifications, maintenance and operation. A detailed parts list was also included.

**Mechanical History:** The castor housing adjustment bolts

were replaced several times during the test period. A few minor problems also occurred.

### RECOMMENDATIONS

It is recommended that the manufacturer consider:

1. Modifying the castor housing assembly to eliminate thread damage during adjustment.
2. Modifying the lock-up pins so they will not work free during transport.
3. Modifying the way the depth stop plunger is secured.
4. Supplying a safety chain as standard equipment in accordance with ASAE standards.

Station Manager: R. P. Atkins

Project Technologist: G. A. Magyar

### THE MANUFACTURER STATES THAT

With regard to recommendation number:

1. The castor housing assembly was redesigned in 1987. The adjustment bolt was increased in size, changed to Acme thread, and relocated for better in-line loading. This provides longer bolt life and easier adjustment.
2. We are unaware of any problem with the lock up pins working free during transport. This problem will be further investigated.
3. The depth stop plunger mount was revised in 1987 and currently uses a heavier set screw.
4. A safety chain will be available on new chisel plow models.

### GENERAL DESCRIPTION

The Flexi-coil 600 chisel plow is a trailing, flexible, three section chisel plow suitable for primary and secondary tillage operations. The test machine was 36 ft (11 m) wide with a 14.2 ft (4.3 m) center frame and two 10.9 ft (3.3 m) wing sections. The hitch and wings are hinged in a unique way to the center frame, which allows all sections to float independent of each other and of the tractor. It has 36 spring-cushion shanks arranged in three rows and spaced at 11.8 in (300 mm) intervals.

The center frame is supported by two tandem walking beam wheel sets and one outrigger wheel, while each wing frame is supported by a one tandem wheel walking beam set and one outrigger wheel. A single hydraulic cylinder controls tillage depth. The wings fold into transport position with four hydraulic cylinders connected in parallel. A tractor with dual remote hydraulic controls is needed to operate the Flexi-coil 600 chisel plow. The test machine was equipped with optional three row tine harrows.

The Flexi-coil 600 chisel plow is available in widths from 34 ft (10.4 m) to 50 ft (15.2 m).

Detailed specifications are given in APPENDIX I while FIGURE 1 shows the location of major components.

**SCOPE OF TEST**

The Flexi-coil 600 was tested during seeding in conjunction with Flexi-coil 1100 and 1600 Air Seeders (Evaluation Report No.'s 549 and 564) and tillage operations in field conditions shown in TABLE 1, for approximately 275 hours while cultivating about 4250 ac (1721 ha). It was evaluated for quality of work, ease of operation and adjustment, power requirements, operator safety, and suitability of the operator's manual.

TABLE 1. Operating Conditions

FIELD CONDITIONS	HOURS	FIELD AREA	
		ac	ha
Operation			
- primary	111.5	1560	632
- secondary	163.5	2690	1089
TOTAL	275.0	4250	1721
Soil Type			
- sandy loam	55.0	930	377
- silt loam	23.0	320	130
- silty clay loam	9.5	100	40
- clay loam	64.0	820	332
- loam	123.5	2080	842
TOTAL	275.0	4250	1721
Stony Phase			
- stone free	103.5	1570	636
- occasional stones	148.5	2360	955
- moderately stony	23.0	320	130
TOTAL	275.0	4250	1721

**RESULTS AND DISCUSSION**  
**QUALITY OF WORK**

**Penetration:** Penetrating ability of the Flexi-coil 600 heavy duty chisel plow when equipped with 16 in (406 mm) sweeps was very good in all field conditions encountered.

Penetration was uniform across the cultivator width provided the frame was properly levelled. The outrigger wheels minimized twisting of the wing frames. The floating hitch and wings enabled the cultivator to maintain uniform tillage depth when working in gently to moderately rolling field conditions.

Maintaining tillage depths required checking and making appropriate adjustments when changing fields to ensure uniform penetration of the Flexi-coil heavy duty chisel plow.

**Depth Uniformity:** Flexibility of the chisel plow frame and shank characteristics (FIGURE 2) determine depth uniformity of the sweeps. Width of the centre and wing sections and how they are linked together determine how well the unit follows the contours of the field. Shank stiffness and cushion spring preload may cause sweep pitch to become excessive, resulting in furrow bottom ridging, rapid sweep tip wear and increased draft. A shank which maintains a low, relatively constant sweep pitch over the normal range of tillage forces was desirable. PAMI has selected seven degrees as a maximum operating steep pitch that will provide an acceptable furrow bottom for most operations.

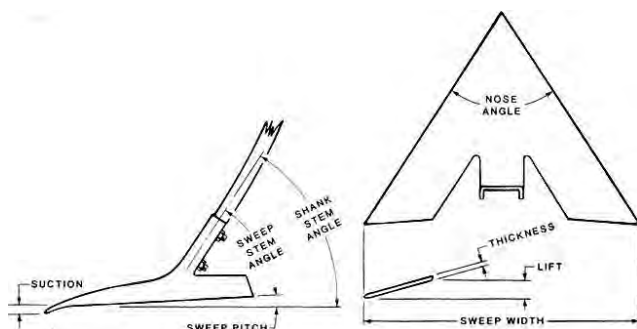

FIGURE 2. Shank and Sweep Terminology.

Depth uniformity of the Flexi-coil 600 was very good in both primary and secondary tillage conditions. The chisel plow followed

rolling contours very well, maintaining uniform depth across the full width. There was some depth variation when crossing gullies or over sharp hill crests.

The sweep pitch characteristics of the Flexi-coil 600 are shown in FIGURE 3. The no-load sweep pitch was 2 degrees. The lower sloped line shows how an increase in force gradually flexed the shank as indicated by a slight increase in sweep pitch. At a horizontal force of 648 lb (2.9 kN), the shank began to trip as the cushion-spring preload was overcome. This is the point on the curve where the steep upper curve begins. At a horizontal trip force of 712 lb (3.2 kN), the sweep pitch curve exceeded 7 degrees. This is the point where the steep curve crosses the shaded grey horizontal line. The maximum sweep pitch of 7 degrees is recommended by PAMI to maintain an acceptable furrow bottom. If a cultivator is operated in conditions where soil forces exceed that value, a non-uniform furrow bottom will result. The curve above the shaded grey line shows how shank force increases as the shank trips over an obstacle.

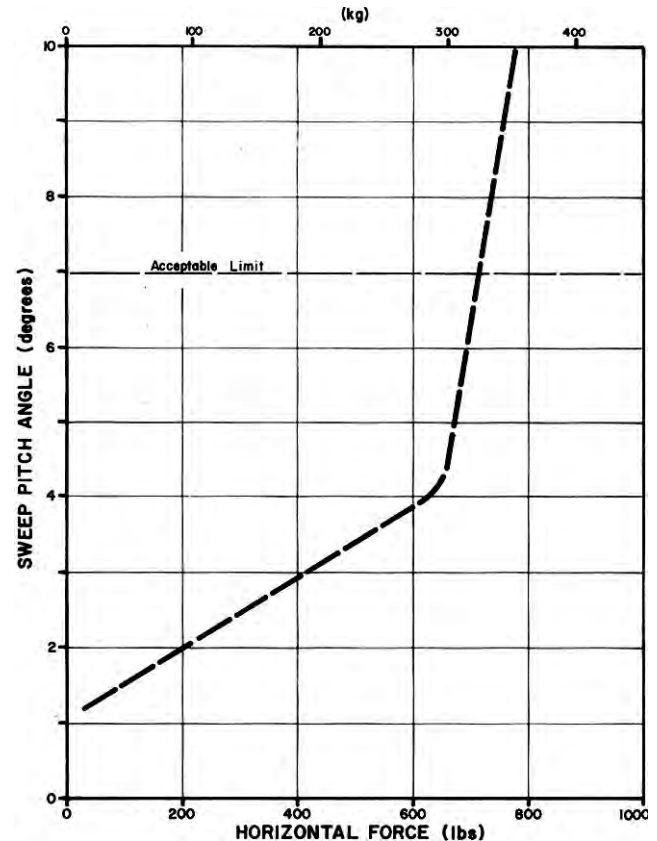

FIGURE 3. Sweep Pitch for Flexi-coil 600 Shank.

Performance of the Flexi-coil 600 can be determined by comparing its sweep pitch characteristics to the actual horizontal force that the shanks will encounter in the field. Research has been conducted to determine the typical prairie soil forces acting on soil tools located in the front row of a cultivator while operating at different depths in primary and secondary tillage (APPENDIX II). The position and subsequent performance of the soil tools can be predicted by comparing the researched soil forces to the counteracting shank force (FIGURE 3) developed by the shank assembly.

The Flexi-coil 600 shank force at a 7 degree sweep pitch was greater than all shown soil forces. This indicates that the 12 and 16 in (305 and 406 mm) sweeps will maintain a uniform tillage or seeding depth while operating in primary and secondary tillage. The Flexi-coil 600 would also maintain 2 in (50 mm) spikes and banding knives at uniform working depth in primary and secondary conditions. This would minimize shank assembly wear as the soil forces would not be causing partial tripping or continuous movement of the assembly.

**Stone protection:** Stone protection was very good. FIGURE 4 shows the lifting pattern when shanks encounter stones or field obstructions. A lift height of 12 in (300 mm) normally prevents shank and sweep damage in fields with large rocks. The maximum lift

height of the Flexi-coil 600 shank assembly was 13 in (330 mm) when equipped with 16 in (406 mm) sweeps. There was no shank damage during the test period.

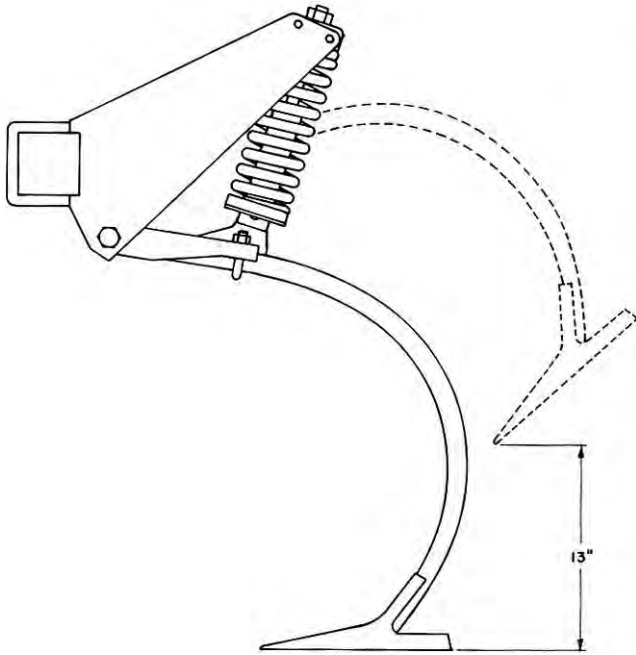

FIGURE 4. Shank Lifting Pattern.

**Trash Clearance:** The trash clearance of the 11.8 in (300 mm) shank spacing heavy duty chisel plow was very good.

The 11.8 in (300 mm) lateral shank spacing and 29.5 in (749 mm) sweep-to-frame clearance was suitable for clearing large amounts of dry trash. In heavy, damp trash, plugging usually occurred at the wheel locations or between the front center shank and the left front shank. Plugging between the shanks was caused

by the narrow lateral spacing (FIGURE 5) between the shanks.

**Surface Finish:** The field surface finish was good with the Flexi-coil 600 heavy duty chisel plow.

In moderate trash conditions, the optional harrows were effective in distributing the trash evenly when properly adjusted. In heavy trash, the harrows were placed into transport position to eliminate plugging. In light trash, the harrows were effective in levelling the ridges left by the chisel plow to produce a uniform seedbed.

**Skewing and Stability:** The Flexi-coil 600 was stable and did not skew in typical field conditions. The sweep pattern (FIGURE 5) was symmetrical and did not impose any side forces on the chisel plow during tillage. Skewing was minimal even on hillsides or where soil hardness varied across the machine width. With the 16 in (406 mm) sweeps, the chisel plow had to skew more than 2.5 degrees for weed misses to occur.

#### EASE OF OPERATION AND ADJUSTMENT

**Maintenance:** Lubrication was convenient with very good access to all grease fittings. The wing pins and depth control chain rollers required greasing daily, while the walking beams, wheel standards, hitch pivot and castor sleeves required weekly greasing. The wheel bearings required greasing every 200 hours.

**Transporting:** Ease of transporting the Flexi-coil 600 chisel plow was good.

The hitch jack and rigid hitch tongue made one man hitching easy. The Flexi-coil 600 was easily placed in transport position by one person in less than five minutes (FIGURE 6). Locks were provided for the wings and the center frame wheels. Wing transport locks were located at all four corners of the chisel plow while the center frame transport locks were located on the center frame wheel standards. All locks could be positioned without climbing on the chisel plow. During transport the front two lock-up pins would work loose and fall out. It is recommended that the manufacturer consider modifying the lock-up pins so the pins will not work free while transporting the chisel plow. The optional harrows could be individually locked in a raised position for greater ground clearance during transport.

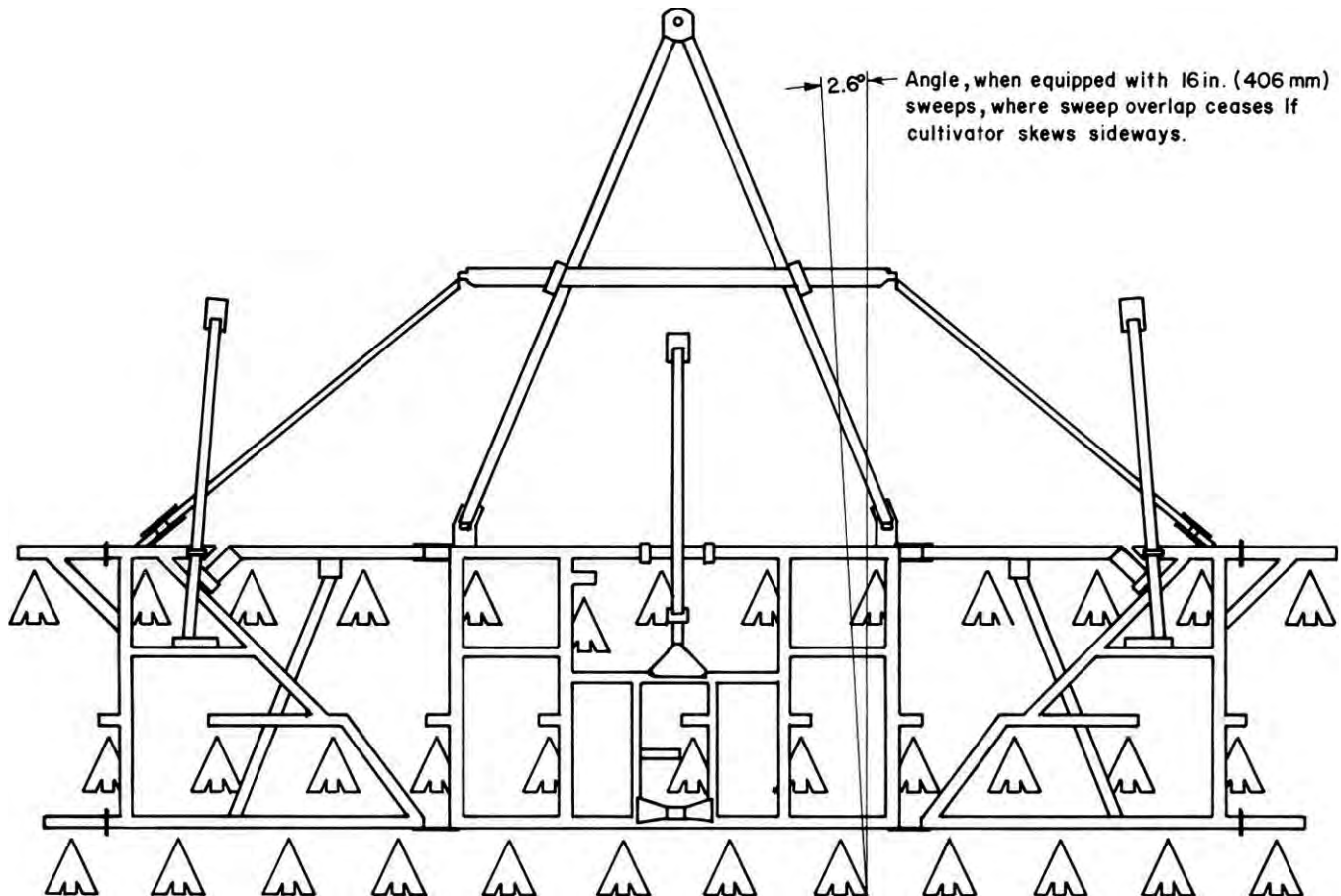

FIGURE 5. Sweep Pattern.

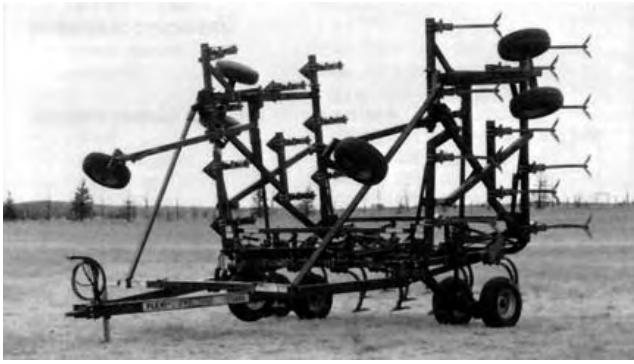

FIGURE 6. Transport Position.

Transport width of the test machine was 22.7 ft (6.9 m), while transport height was 14.6 ft (4.5 m). Extreme care was needed when transporting on public roads, through gates, over bridges and beneath power lines.

Sufficient clearance between the tractor rear tires and the chisel plow hitch allowed for sharp turns in both field and transport positions.

The Flexi-coil 600 towed well without sway or bounce at normal transport speed. A sweep-to-ground clearance of 9.0 in (229 mm) provided sufficient ground clearance.

**Frame Levelling:** Ease of levelling the frame was good. A thrust bar adjuster bolt (FIGURE 7) connected to the depth control linkage provided lateral levelling of the main frame and wing sections. Front-to-back levelling was obtained by adjusting the height of the outrigger castor forks (FIGURE 8). Pressure exerted on the castor housing adjustment bolt would strip the threads as adjustments were made. This required replacement of the adjustment bolt. It is recommended that the manufacturer consider modifying the castor housing assembly to eliminate thread damage during adjustment.

The floating hitch eliminated the need to adjust the hitch height.



FIGURE 7. Thrust bar adjuster bolt.

**Depth Adjustment:** Ease of setting the tillage depth was very good. Tillage depth was controlled by a single hydraulic cylinder mechanically connected to each set of depth control wheels (FIGURE 7). A hydraulic stop valve on the control cylinder was adjusted to set tillage depth. Each time the tillage depth was set, equivalent adjustments to the outrigger castor wheels were required.

**Harrow Adjustment:** Ease of adjusting the optional tine harrows was very good. The harrow frame was levelled by loosening two bolts and then rotating the harrow gang on the cross tube until the harrows were level with the chisel plow frame. The tine angle could be adjusted to five different positions. Adjustments for tine angle and harrow spring preload were adequate for most conditions.

#### POWER REQUIREMENTS

PAMI has measured power requirements on several cultivators in various field conditions as explained in APPENDIX III. From these field measurements, average power requirements have been determined to assist farmers in matching tractor and cultivator sizes.

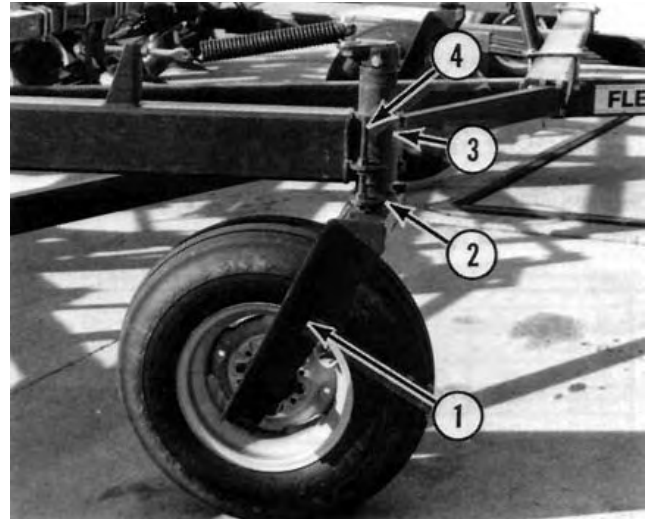

FIGURE 8. Outrigger Castor Fork: (1) Castor Fork Assembly, (2) Castor Adjustment Sleeve, (3) Castor Housing, (4) Castor Housing Adjustment Bolt.

The tractor sizes (TABLE 2) have been adjusted to include tractive efficiency and represent a tractor operating at 80% of maximum power take-off rating.

TABLE 2. Tractor Size: PTO Power (hp(kW)) Required to Operate a Typical 36 ft (11 m) Chisel Plow

OPERATION	DEPTH in (mm)	SPEED - mph ( km/h)	
		5.0 (8.0)	6.0 (9.7)
PRIMARY	3.0 (75)	172 (128)	208 (155)
	4.0 (100)	218 (162)	265 (197)
SECONDARY	3.0 (75)	154 (114)	186 (138)
	4.0 (100)	200 (149)	243 (181)

In typical secondary tillage conditions at a speed of 5 mph (8 km/h) and a depth of 3 in (75 mm), average cultivator power requirements were 4.3 hp/ft (10.5 kW/m) (APPENDIX III). In typical primary tillage conditions at the same speed and depth average power requirements were 4.9 hp/ft (11.7 kW/m). Therefore, the tractor PTO horsepower recommended to pull 36 ft (11 m) of Flexi-coil 600 chisel plow under these conditions would be 155 hp (115 kW) in secondary conditions and 173 hp (129 kW) in primary conditions. Additional power will be required when tilling deeper or working in hilly terrain.

#### OPERATOR SAFETY

The Flexi-coil 600 chisel plow was 22.7 ft (6.9 m) wide in transport, which necessitated caution when towing on public roads, over bridges and through gates. A slow moving vehicle sign was provided as standard equipment. A hitch safety chain for transporting on public roads was not supplied. It is recommended that the manufacturer consider supplying the safety chain as standard equipment in accordance with American Society of Agricultural Engineers' safety standards.

When in transport position with harrows attached, the load on the center section tires did not exceed The Tire and Rim Association's maximum load rating.

#### OPERATOR'S MANUAL

The operator's manual was very good. The operator's manual for the Flexi-coil 600 chisel plow contained useful information on safety, assembly, adjustment, specifications, maintenance and operation. A detailed parts list was also included.

#### MECHANICAL HISTORY

TABLE 3 outlines the mechanical history of the Flexi-coil 600 chisel plow during 275 hours of field operation while cultivating 4250 ac (1721 ha). The intent of the test was evaluation of functional performance. An extended durability evaluation was not conducted.

**TABLE 3. Mechanical History**

ITEM	OPERATING HOURS	EQUIVALENT FIELD AREA	
		ac	(ha)
-Replaced castor housing adjustment bolts at		Beginning of Test	
	33, 127, 184, 220	608, 2304, 3314, 3766	(246, 933, 1344, 1525)
-Replaced lost lock up pins at		Beginning of Test	
	33, 96, 102, 127	608, 1696, 1824, 2304	(246, 687, 738, 933)
-Replaced lost cylinder pin at	15	340	(138)
-Replaced faulty depth stop valve at	132	2440	(988)
-Replaced chain junction/ support tube and set screws at	138	2567	(1038)
-Replaced broken bolts on mechanical depth linkage at	150	2780	(1126)

**Depth Stop Valve:** The depth stop valve tended to leak on a continuous basis when in field position. The manufacturer supplied a new valve and the problem was corrected.

**Bolts on Mechanical Linkage:** The bolts connecting the mechanical linkage to the depth control assembly were sheared. The bolts were replaced and no further problems were encountered.

**Chain Junction/Support Tube:** The depth control plunger was set by loosening the set screws in the chain junction/support tube (FIGURE 9), then moving the plunger and retightening the screws. When securing the depth control plunger, the set screws would break off in the chain junction/support tube. It is recommended that the manufacturer consider modifying the way the depth control plunger is secured.

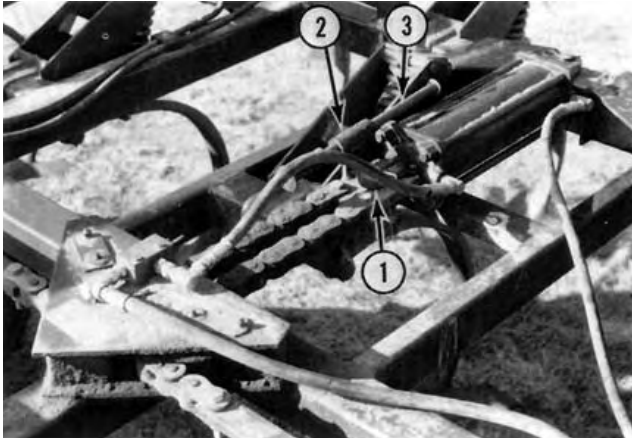

**FIGURE 9.** Depth Control Assembly: (1) Chain Junction Support Tube, (2) Set Screws, (3) Depth Control Plunger.

**APPENDIX I**

**SPECIFICATIONS**

<b>MAKE:</b>	Flexi-coil	
<b>MODEL:</b>	600	
<b>SERIAL NUMBER:</b>	S600-A00-E002708	
<b>MANUFACTURER:</b>	Flexi-coil 1000 71 Street E Saskatoon, Saskatchewan S7K 3B5 Phone (306) 934 3500	
	<b>FIELD POSITION</b>	<b>TRANSPORT POSITION</b>
<b>DIMENSIONS:</b>		
-width	36.0 ft (11.0 m)	22.7 ft (6.9 m)
-length	25.2 ft (7.7 m)	25.2 ft (7.7 m)
-height	5.4 ft (1.6 m)	14.8 ft (4.5 m)
-maximum ground clearance	9.0 in (229 mm)	9.0 in (229 mm)
-maximum wheel tread	33.9 ft (10.3 m)	15.5 (4.7 m)
<b>SHANKS:</b>		
-number	36	
-lateral spacing	11.8 in (300 mm)	
-trash clearance	29.5 in (749 mm)	
-number of shank rows		
-center	3	
-wings	3	
-distance between rows	33.5 in (851 mm)	
-cross section	1.25 x 2 in (32 x 51 mm)	
-angle	52 degrees	
-sweep hole spacing	25 in (64 mm)	
-sweep bolt size	0.5 in (13 mm)	
<b>HITCH:</b>		
-floating	Eliminates hitch height adjustment	
<b>DEPTH CONTROL:</b>	Hydraulic	
<b>FRAME:</b>		
-main cross section	4 in (102 mm) square tubing	
-wing cross section	4 in (102 mm) square tubing	
<b>TIRES:</b>		
-center section	Four, 11 - 15 LT, 6 ply	
-wing sections	Four, 9.5L - 15, 6 ply	
-outrigger wheels	Three, 9.5L - 15, 6 ply	
<b>NUMBER OF LUBRICATION POINTS:</b>		
-grease fittings		
<b>HYDRAULIC CYLINDERS:</b>		
-depth control	Four, 5.0 x 14 in (127 x 356 mm)	
-wing lift	Four, 4.0 x 24 in (102 x 610 mm)	
<b>WEIGHTS:</b>	<b>FIELD POSITION</b>	<b>TRANSPORT POSITION</b>
(without harrows)		
-hitch	630 lb (286 kg)	1490 lb (678 kg)
-right outrigger	670 lb (305 kg)	
-right wing	1660 lb (755 kg)	
-right center	3460 lb (1573 kg)	5320 lb (2418 kg)
-middle outrigger		
-left center	3590 lb (1632 kg)	5410 lb (2459 kg)
-left wing	1570 lb (714 kg)	
-left outrigger	640 lb (290 kg)	
<b>TOTAL</b>	<b>12,220 lb (5555kg)</b>	<b>12,220 lb (5555kg)</b>
<b>OPTIONAL EQUIPMENT AVAILABLE:</b>		
-8 width options from 34 to 50 ft (104 to 152 m)		
-4.5 to 6 ft (1.4 to 1.8 m) four row mounted harrows		

**APPENDIX II**

**SOIL FORCE TABLES**

The following tables give typical horizontal forces acting on sweeps, spikes, and banding knives located in the front row of a cultivator while operating at different depths in primary and secondary tillage on the prairies. Higher forces may be encountered in extremely heavy, dry or compacted soils. These values can be used to determine how well the shank assemblies are suited to the various operations. Comparing the sweep pitch curve of the assembly to these soil forces will indicate whether the assembly will hold the soil tool below the acceptable 7 degree sweep pitch.

**TABLE 4.** Forces Required (lb (kN)) in Primary Tillage for Various Soil Tools

DEPTH in (mm)	SWEEPS			SPIKE	BANDING KNIFE
	FIELD CULT	HEAVY DUTY CULT			
	11 in (275 mm)	12 in (305 mm)	16 in (406 mm)	2 in (50 mm)	1 in (25 mm)
	lb (kN)	lb (kN)	lb (kN)	lb (kN)	lb (kN)
2 (50)	120 (0.5)	190 (0.8)	220 (1.0)	–	–
3 (75)	140 (0.6)	230 (1.0)	260 (1.2)	150 (0.7)	–
4 (100)	180 (0.8)	310 (1.4)	370 (1.6)	190 (0.8)	320 (1.4)
5 (125)	–	420 (1.9)	500 (2.2)	260 (1.2)	390 (1.7)
6 (150)	–	–	–	360 (1.6)	540 (2.4)

**TABLE 5.** Forces Required (lb (kN)) in Secondary Tillage for Various Soil Tools

DEPTH in (mm)	SWEEPS			SPIKE	BANDING KNIFE
	FIELD CULT	HEAVY DUTY CULT			
	11 in (275 mm)	12 in (305 mm)	16 in (406 mm)	2 in (50 mm)	1 in (25 mm)
	lb (kN)	lb (kN)	lb (kN)	lb (kN)	lb (kN)
2 (50)	110 (0.5)	170 (0.8)	200 (0.9)	–	–
3 (75)	140 (0.6)	220 (1.0)	270 (1.2)	130 (0.6)	–
4 (100)	170 (0.8)	280 (1.2)	340 (1.5)	180 (0.8)	290 (1.3)
5 (125)	–	370 (1.6)	450 (2.0)	290 (1.1)	380 (1.7)
6 (150)	–	–	–	320 (1.4)	490 (2.2)

**APPENDIX III**

**POWER REQUIREMENTS**

**Draft Characteristics:** Draft requirements have been treasured on several cultivators in various field conditions over the past years Average draft requirements have been determined from these requirements

Draft requirements for the same cultivator, in the same field, may vary by as much as 30% in two different years due to changes in soil conditions Variations in soil conditions affect draft much more than variations in machine make, making it difficult to measure any significant draft differences between make of cultivators

Since there is little or no draft differences between machines, PAMI has averaged the results obtained over the years and has used these to determine tractor size requirements

**Recommended Tractor Size:** The following tables show tractor PTO power required to pull cultivators in various conditions at the given depths and speeds Tractor power requirements have been adjusted to include a tractive efficiency of 80% in primary and 70% in secondary tillage and represent a tractor operating at 80% of maximum PTO power on a level field These power requirements can be used along with the maximum PTO ratings, as determined by Nebraska tests or as presented by the tractor manufacturer, to select the appropriate tractor Higher power will be required in hills or in heavy soils Cultivators with marked differences in spacing, number of rows, or configuration may require more or less power

Recommended tractor size may be determined by selecting the required horsepower per foot from the appropriate table and multiplying by the width of the cultivator For example, in primary tillage at 4 in (100 mm) and 5 mph (8 km/h), 61 hp/ft (149 kW/m) is required Therefore, for a 36 ft (11 m) cultivator in those conditions, 220 PTO hp (164 kW) is recommended

**TABLE 6.** Tractor PTO Power Per Unit Width (hp/ft (kW/m)) Required in Primary Tillage

DEPTH in (mm)	SPEED - mph (km/h)		
	4.0 (6.4)	5.0 (8.0)	6.0 (9.7)
2 (50)	2.7 (6.6)	3.4 (8.3)	4.1 (10.0)
3 (75)	3.8 (9.3)	4.8 (11.7)	5.8 (14.2)
4 (100)	4.9 (12.0)	6.1 (14.9)	7.4 (18.1)
5 (125)	6.0 (14.7)	7.5 (18.4)	9.0 (22.0)

**TABLE 7.** Tractor PTO Power Per Unit Width (hp/ft (kW/m)) Required in Secondary Tillage

DEPTH in (mm)	SPEED - mph (km/h)		
	4.0 (6.4)	5.0 (8.0)	6.0 (9.7)
2 (50)	2.3 (5.6)	3.0 (7.3)	3.6 (8.8)
3 (75)	3.4 (8.3)	4.3 (10.5)	5.2 (12.7)
4 (100)	4.5 (11.0)	5.6 (13.7)	6.8 (16.6)
5 (125)	5.5 (13.5)	7.0 (17.1)	8.4 (20.6)

**APPENDIX IV**

**MACHINE RATINGS**

The following rating scale is used in PAMI Evaluation Reports:

- |           |                |
|-----------|----------------|
| Excellent | Fair           |
| Very Good | Poor           |
| Good      | Unsatisfactory |

## SUMMARY CHART

### FLEXI-COIL 600 CHISEL PLOW

#### RETAIL PRICE:

\$28,760.00

(July, 1988 f.o.b. Lethbridge)

36 ft (11 m) width, complete with 3-bar mounted harrows and setup.)

#### QUALITY OF WORK:

Penetration

**Very Good.**

Depth

Uniformity **Very Good**; level furrow bottom in primary and secondary conditions.

Stone

Protection **Very Good**; trip height was 13 in (330 mm)

Trash

Clearance **Very Good**; would plug in heavy, we trash.

Surface Finish

**Good**; in light to moderate trash condition harrows were effective.

Skewing and Stability

Stable.

#### EASE OF OPERATION AND ADJUSTMENT:

Maintenance

**Very Good**; convenient access.

Transporting

**Good**; lock-up pins tended to work loose during transport. Easy to manoeuvre.

Frame Levelling

**Good.**

Depth Adjustment

**Very Good**; easily changed.

Harrow Adjustment

**Very Good**; easily changed.

#### POWER REQUIREMENTS:

Secondary Tillage

154 hp (115 kW) at 3 in (75 mm) and 5 mph (8 km/h)

Primary Tillage

173 hp (129 kW) at 3 in (75 mm) and 5 mph (8 km/h)

#### OPERATOR SAFETY:

Safe if normal precautions observed.

#### OPERATOR'S MANUAL:

**Very Good**; well written and clearly illustrated.

#### MECHANICAL HISTORY:

Castor housing adjustment bolts were replaced several times during the test.



3000 College Drive South  
Lethbridge, Alberta, Canada T1K 1L6  
Telephone: (403) 329-1212  
FAX: (403) 329-5562  
<http://www.agric.gov.ab.ca/navigation/engineering/afmrc/index.html>

### Prairie Agricultural Machinery Institute

Head Office: P.O. Box 1900, Humboldt, Saskatchewan, Canada S0K 2A0

Telephone: (306) 682-2555

#### Test Stations:

P.O. Box 1060

Portage la Prairie, Manitoba, Canada R1N 3C5

Telephone: (204) 239-5445

Fax: (204) 239-7124

P.O. Box 1150

Humboldt, Saskatchewan, Canada S0K 2A0

Telephone: (306) 682-5033

Fax: (306) 682-5080