

# Evaluation Report

# 472

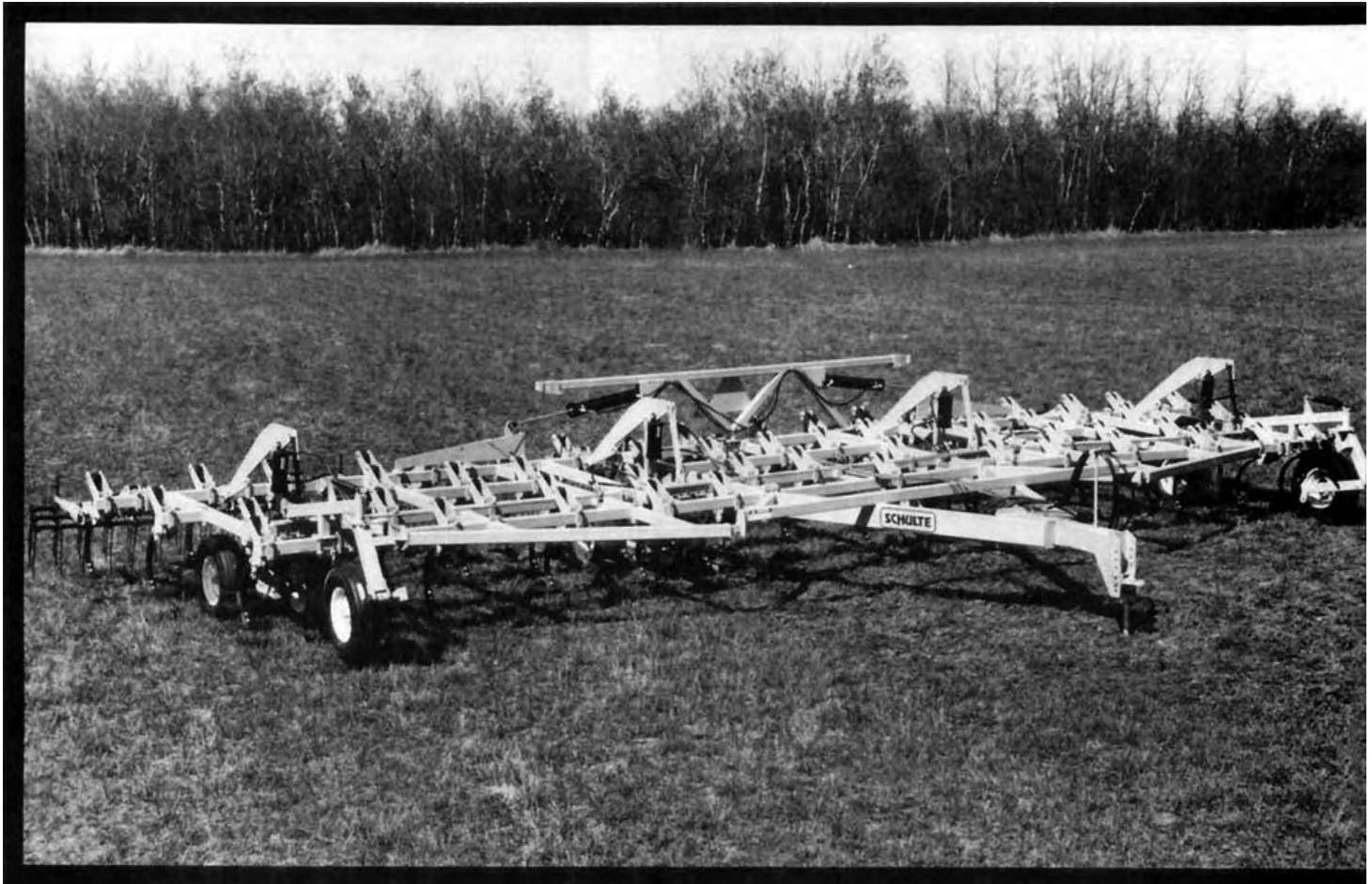

## Schulte 300 Mid-Range Heavy Duty Cultivator

A Co-operative Program Between



# SCHULTE 300 MID-RANGE HEAVY DUTY CULTIVATOR

## MANUFACTURER:

Schulte Industries Ltd.  
P.O. Box 70  
Englefeld, Saskatchewan  
S0K 1N0

## RETAIL PRICE:

\$24,800.00 [February, 1986, f.o.b. Humboldt, 42.7 ft (13.0 m) width, with optional mud scrapers, harrows, and Edwards sweeps].

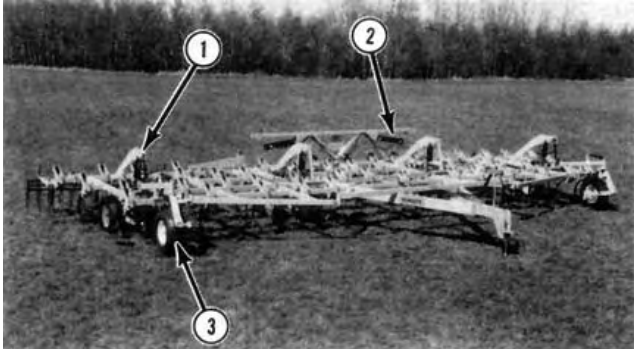

FIGURE 1. Schulte 300: (1) Depth Control Cylinders, (2) Wing Lift Cylinders, (3) Stabilizer Wheel.

## SUMMARY AND CONCLUSIONS

**Quality of Work:** The Schulte 300 was suitable for secondary and light primary tillage, and most heavy primary tillage when equipped with 12 in (305 mm) sweeps. Shank tripping occurred in very heavy primary tillage or when deep banding fertilizer with banding knives. The spring cushioned shanks could lift 11.7 in (297 mm) to clear stones. When equipped with 50 degree sweeps, sweep pitch ranged from 2 to 5 degrees over the normal range of tillage draft. Shank cushion spring preload was exceeded at drafts greater than 573 lb/ft (8.4 kN/m).

Penetration was very good in most conditions. In very heavy primary tillage, furrow bottom ridging occurred as the draft exceeded the cushion spring preload.

Trash clearance was very good. However, plugging occurred near the wheels when damp or large amounts of dry trash were encountered. The field surface left by the Schulte 300 was good provided fine harrows were used. The harrows left bunches typical of all mounted harrows on the field surface in heavy trash.

Weed kill was good except in heavy trash where the harrows were less effective.

**Ease of Operation and Adjustment:** Ease of hitching to the Schulte 300 was very good. The rigid hitch link and hitch jack made one man hitching easy. Ease of transporting the Schulte 300 was fair. It could be placed into transport in less than 5 minutes. Because of its very high transport height and wide transport width, moving on public roads required extreme caution. Bouncing of the hitch occurred at speeds over 15 mph (24 km/h). Maneuverability was very good.

Ease of levelling was good. Adjustment was provided for front-to-back levelling of the centre frame section and the wings. The wings could also be adjusted laterally. Ease of setting the tillage depth was very good. An adjustable stop collar on the main control cylinder allowed setting of the tillage depth. Ease of adjusting the optional mounted fine harrows was good. Ease of installing sweeps and shanks was very good. About 5 minutes was required to install a new shank.

**Safety:** The Schulte 300 was equipped with centre frame and wing transport locks. Transport height was high enough that over head power lines could be contacted while moving. A slow moving vehicle sign was provided. In transport the tires of the centre section were overloaded by 28%. When lifting the wings into the transport position, the lift cylinder pins bent. Personal injury and damaged cultivator parts could result if the pins failed.

**Operator's Manual:** An operator's manual was not available for the Schulte 300 cultivator during the tests.

**Mechanical History:** A diagonal twist was found in the centre frame section during testing. The pins at the cylinder end of the wing lift cylinders and eleven shanks bent during testing. Three of the shanks bent when they hit the frame. A ratchet jack handle on the front stabilizer wheel bent.

## RECOMMENDATIONS

It is recommended that the manufacturer consider:

1. Modifications to the lock on the wing levelling ratchet jacks to make adjusting the jacks more convenient.
2. Modifications to prevent the depth stop collars from seizing.
3. Modifications to prevent bending of the wing lift cylinder pins when raising the wings into transport.
4. Supplying an operator's manual for the Schulte 300 cultivator.
5. Modifications to reduce shank bending.
6. Modifications to prevent the ratchet jack handle on the stabilizer wheels from bending when hitting the stabilizer wheel frame.

Senior Engineer: G.E. Frehlich

Project Engineer: H.D. Kydd

Project Technologist: M.J. Bennett

## THE MANUFACTURER STATES THAT:

With regard to recommendation number:

1. The wing levelling ratchet jack locks will be modified, so that the operator will not be required to hold the lock device out of the way while making level adjustments to the wing frames,
2. The hydraulic cylinder depth stop collars will be fitted with grease fittings and seals in order to prevent the threads from rusting.
3. Pins will be made of a higher strength material to prevent bending.
4. An operator's manual will be made available to all owners of Schulte cultivators.
5. Frame depth will be increased to allow more clearance for shanks.
6. The castor wheel assembly used on the test machine has since been replaced by, an assembly which does not require a ratchet jack.

## GENERAL DESCRIPTION

The Schulte 300 mid-range cultivator is a trailing three section cultivator suitable for both primary and secondary tillage in most field conditions. It is available in widths from 24.7 to 42.7 ft (7.5 to 13.0 m). The test machine is 42.7 ft (13.0 m) wide with a 15.1 ft (4.6 m) centre frame and two 13.7 ft (4.2 m) wide wing sections. It has 57 spring cushioned shanks spaced 9 in (230 mm) apart, and arranged in four rows.

The centre frame is carried on two walking axle wheel sets while each wing frame is supported by one walking axle wheel set and one stabilizer wheel. Four hydraulic cylinders connected in series control tillage depth. The wings fold into transport position with two hydraulic cylinders connected in parallel. A tractor with dual remote hydraulic circuits is needed to operate the Schulte 300 mid-range cultivator. The test machine is also equipped with optional three row fine harrows and mud scrapers.

Detailed specifications are given in APPENDIX I and FIGURE 1 shows the location of major components.

## SCOPE OF TEST

The Schulte 300 was evaluated in the field conditions shown in TABLE 1 for 103 hours while cultivating 1585 ac (641 ha). It was also used for an additional 80 hours to deep band fertilizer over 1800 ac (730 ha) during evaluation of a fertilizer banding attachment. It was evaluated for quality of work, ease of operation and adjustment, power requirements, safety, and suitability of the operator's manual.

## RESULTS AND DISCUSSION

### QUALITY OF WORK

**Shank Characteristics:** Many manufacturers use different shank and sweep stem angles (FIGURE 2) when designing their

cultivators. To achieve and maintain penetration, sweeps and shanks are matched to obtain sufficient sweep pitch. Usually manufacturers recommend sweeps with a stem angle 0 to 5 degrees less than the shank stem angle to provide a slightly positive no-load sweep pitch.

TABLE 1. Operating Conditions

FIELD CONDITIONS	HOURS	FIELD AREA	
		ac	ha
Soil Type			
- sand	14	190	77
- light loam	29	350	142
- loam	31	540	218
- clay	29	505	204
TOTAL	103	1585	641
Stony Phase			
- stone free	31	555	226
- occasional stones	46	730	295
- moderately stony	11	110	44
- very stony	13	190	77
TOTAL	163	1585	641
ADDITIONAL USE FOR EVALUATING A FERTILIZER BANDING ATTACHMENT			
BANDING FERTILIZER	80	1800	730
OVERALL TOTAL	183	3385	1371

Sweep pitch increases in proportion to draft due to shank flexing. Depending on shank stiffness and cushion spring preload, sweep pitch may become excessive on some cultivators in normal tillage. A slightly positive sweep pitch results in uniform tillage depth and a smooth furrow bottom, while excessive sweep pitch causes furrow bottom ridging, rapid sweep tip wear, and increased draft. Shanks which maintain a low, relatively constant sweep pitch over the normal range of tillage forces, are desirable.

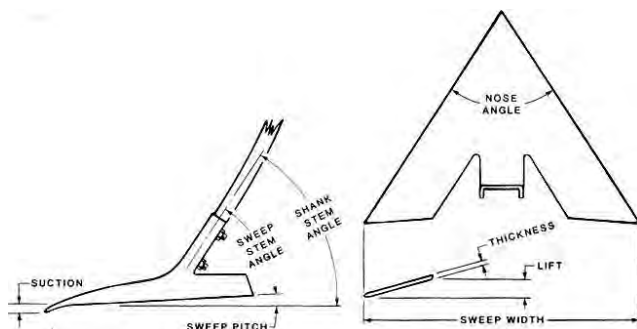

FIGURE 2. Shank and Sweep Terminology

The Schulte 300 cultivator was equipped with 57 spring cushioned shank mechanisms spaced at 9 in (230 mm). Spring tension was not adjustable. The Schulte 300 was equipped with 12 in (305 mm) Edwards sweeps having a 50 degree stem angle. This gave a no-load sweep pitch of 2 degrees.

FIGURE 3 shows the sweep pitch characteristics of the shank assemblies on the Schulte 300. The lower slope line results from shank flexing, while the steep upper line occurs when draft is large enough to overcome the cushion spring preload. Over the normal tillage draft range, sweep pitch varied 3 degrees. With the 50 degree sweeps, this represents a working sweep pitch range from 2 to 5 degrees. Cushion spring preload was exceeded at a draft of 573 lb/ft (8.4 kN/m). This occurred at the upper end of the primary tillage range. This shows that the Schulte 300 cultivator was suitable for all secondary and light primary, and most heavy primary tillage when equipped with 12 in (305 mm) sweeps.

FIGURE 4 shows the lifting pattern when shanks encountered stones or field obstructions. Maximum lift height was 11.7 in (297 mm) when equipped with Edwards 12 in (305 mm) sweeps.

**Penetration:** Penetration was very good in most field conditions. In secondary and most primary tillage, the spring cushioned shanks held the sweeps level, resulting in an even furrow bottom. In very heavy primary tillage, furrow bottom ridging occurred as the draft exceeded the cushion spring preload.

Initially, uniformity of the tillage depth across the cultivator width was poor due to a diagonal twist in the centre section frame. After the

manufacturer replaced the centre frame section, uniformity of tillage depth was very good when the cultivator was properly levelled. The front stabilizer wheels minimized twisting of the wing frames. As with most rigid hitch cultivators, large variations in tillage depth occurred in fields with abrupt contour changes.

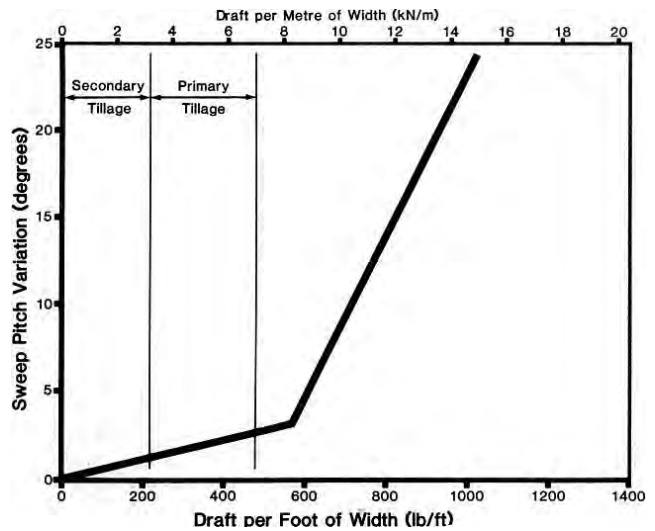

FIGURE 3. Sweep Pitch Variation Over a Normal Range of Draft [12 in (305 mm) Shank Spacing]

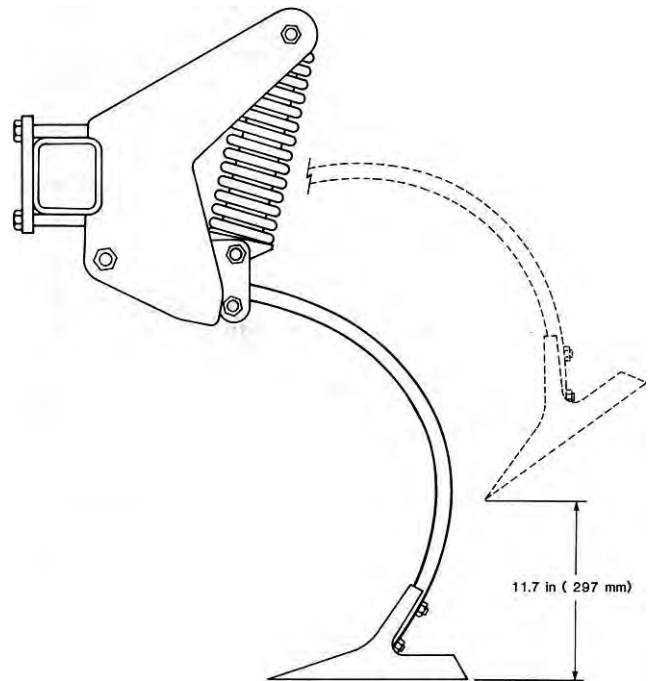

FIGURE 4. Shank Lifting Pattern

**Trash Clearance:** Trash clearance of the Schulte 300 was very good. The 9 in (230 mm) shank spacing and 26 in (660 mm) sweep to frame clearance was suitable for clearing large amounts of dry straw and weeds. Large amounts of damp trash plugged the cultivator at different locations. Plugging occurred most often near the wing wheel positions.

**Trash Burial and Field Surface:** In moderate trash conditions, the harrows were effective in distributing the trash evenly when properly adjusted. In heavy trash, the harrows left bunches on the field surface (FIGURE 5), typical of all mounted harrows. In light trash, the harrows were effective in levelling the ridges left by the cultivator to produce a uniform seedbed (FIGURE 6).

**Skewing and Stability:** The Schulte 300 was equipped with a telescopic hitch pole. With the hitch pole at its shortest position, side-to-side skewing occurred in normal field conditions. When the hitch pole was lengthened, skewing was minimal even on hillsides or where soil hardness varied across the machine width. The sweep

pattern (FIGURE 7) was symmetrical and did not impose any side forces on the cultivator during normal tillage. With 12 in (305 mm) sweeps, the cultivator had to skew more than 1.8 degrees for weed misses to occur.



FIGURE 5. Typical Field Surface in Heavy Trash Conditions



FIGURE 6. Typical Seedbed Preparation

**Weed Kill:** Weed kill was good with the 12 in (305 mm) sweeps and 9 in (230 mm) shank spacing. The finishing harrows were effective in exposing weeds in light trash conditions. The harrows were less effective in heavy trash conditions.

**EASE OF OPERATION AND ADJUSTMENT**

**Hitching:** Ease of hitching to the Schulte 399 was very good. The rigid hitch link and hitch jack made one man hitching easy. Hitch weight was positive in transport and field position with mounted harrows. The hitch jack was long and slightly unstable. Care was needed to position it properly when unhooking the cultivator.

**Transporting:** Ease of transporting the Schulte 300 was fair. It could be placed in transport position (FIGURE 8) by one person in less than 5 minutes. Locks were provided for the wings and the centre frame wheels.

The wing transport locks were easily positioned. However, it was necessary to climb onto the cultivator frame to position the centre frame transport locks.

Transport height of the test machine was 172 ft (5.2 m), while transport width was 23.9 ft (7.3 m). This was high enough to contact many of the rural electrical supply lines. Extreme caution was needed when transporting on public roads, through gates, over bridges, and beneath power lines.

The Schulte 300 towed well, without sway below 15 mph (24 km/h). At speeds over 15 mph (24 km/h), bouncing of the hitch occurred. If towed by a truck or light tractor, the bouncing could cause an unstable condition. A sweep-to-ground clearance of 8.7 in (222 mm) was sufficient, and a wheel tread of 12.9 ft (3.9 m) provided adequate stability while transporting in field or road position.

**Maneuverability:** Maneuverability of the Schulte 300 was very good. The rear wheels of the 4 wheel drive test tractor did not contact the hitch during the tests. There were a sufficient number of sweeps beyond the wing wheels to allow moderate overlap without running a wheel on the cultivated surface. Running all wheels on untilled soil helps maintain proper flotation and a uniform tillage depth.

**Frame Levelling:** Ease of frame levelling was good. No lateral levelling adjustments were provided for the centre section. Initially, the centre section could not be levelled due to a diagonal twist in the frame. Replacing the frame eliminated the twist. A ratchet jack provided adequate lateral levelling for each wing section. The lock levers on the ratchet jacks had to be held up making the adjustment inconvenient (FIGURE 9). It is recommended that the manufacturer consider modifications to prevent this.

Front-to-back levelling was accomplished by adjusting the hitch height. Hitch height could be adjusted 10 in (254 mm) in eight increments by removing two pins. This range of adjustment was not adequate for levelling the cultivator when banding fertilizer at shallow depths with the tractor used. This problem may also occur with other tractors with low drawbar heights when banding with long banding knives.

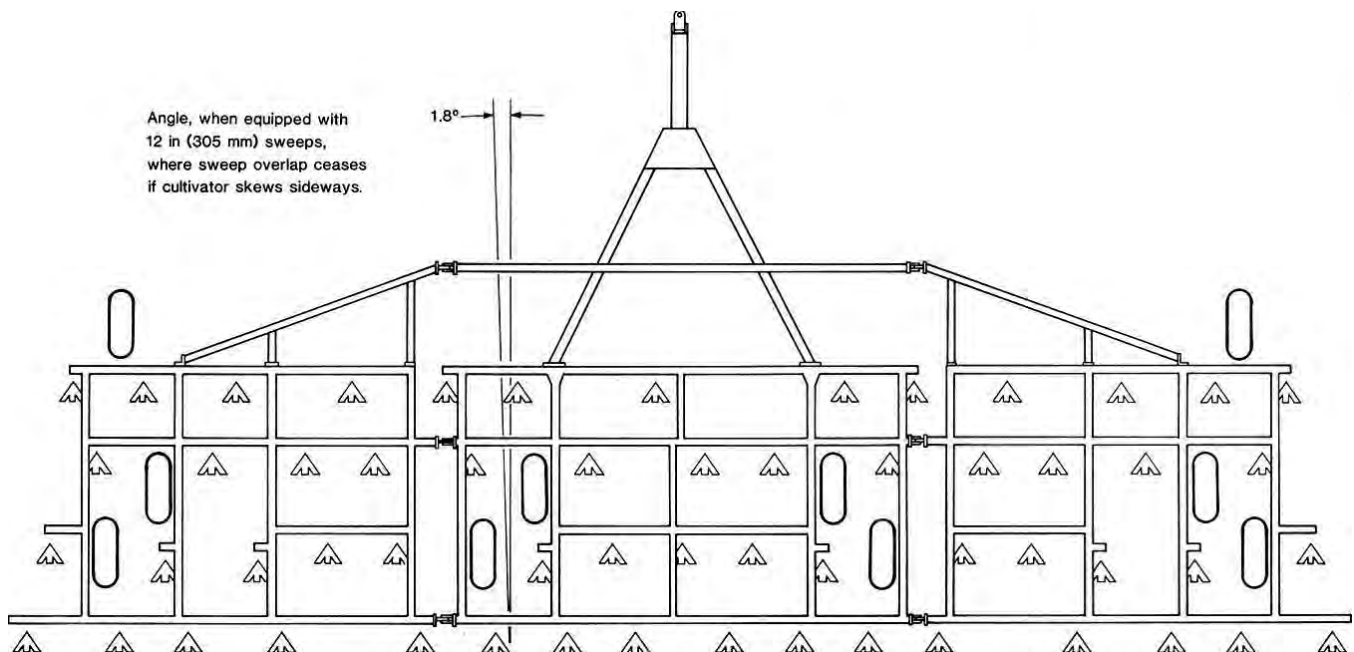

FIGURE 7. Sweep Pattern

**Depth Adjustment:** Ease of setting the tillage depth was very good. Tillage depth was controlled with four hydraulic cylinders connected in series. Each cylinder was equipped with an adjustable stop collar but only the one on the main cylinder was needed to set tillage depth. During testing, the stop collars seized due to dust and corrosion. It is recommended that the manufacturer consider modifications to prevent this problem.

In damp conditions, mud build-up on cultivator tires can cause variations in tillage depth. The optional mud scrapers prevented this. Occasionally, mud and straw lodged between the scraper and tire. To ensure uniform tillage depth, the hydraulic cylinders had to be synchronized periodically by completely extending them to a fully raised position.

**Harrow Adjustment:** Ease of adjusting the optional tine harrows was good. The harrow frame could be levelled by loosening four U-bolts. Adjustments of harrow depth, tine angles and spring pressure were sufficient for most conditions.

**Sweep and Shank Installation:** It took one person about three hours to replace the 57 sweeps on the Schulte 300. Soil abrasion damaged the bolt threads and hampered the removal of the nuts. Shank replacement was very good. It took less than 5 minutes to install a new shank.

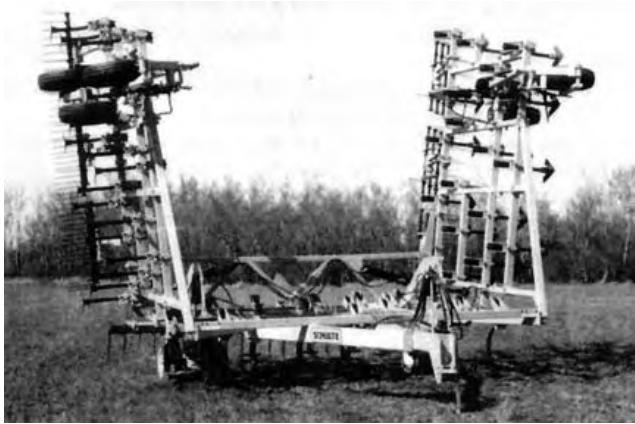

FIGURE 8. Transport Position

## POWER REQUIREMENTS

**Draft Characteristics:** FIGURE 10 shows draft requirements for cultivators in typical primary and secondary tillage at a speed of 5 mph (8 km/h). This figure gives average requirements based on tests of 27 cultivators and 53 different field conditions. Attempting to compare draft requirements of different makes of cultivators is usually unrealistic. Draft requirements for the same cultivator in the same field, may vary by as much as 30% in two different years, due to changes in soil conditions.

Usually variations in soil conditions affect draft much more than variations in machine make, making it impossible to measure any significant draft differences between makes of cultivators. However, in recent years, with the advent of air seeders, cultivators such as the Schulte 300 have been designed for heavy primary tillage, but have shank spacings less than the 12 in (305 mm) spacings normally used for heavy duty cultivators.

Tests in the past two years have shown that cultivators with the narrower shank spacings will have higher draft requirements than the same size conventional heavy duty cultivator. The draft and power requirements shown here for primary tillage are based on the conventional 12 in (305 mm) spacing. Cultivators with narrower shank spacing may have considerably higher draft when operating at the same depth and speed.

In light secondary tillage, such as seedbed preparation and herbicide incorporation, average draft at 5 mph (8 km/h) varied from 55 lb/ft (0.8 kN/m) at 1.6 in (40 mm) depth to 150 lb/ft (2.2 kN/m) at 4 in (100 mm) depth. For the 42.7 ft (13 m) wide test machine, this corresponds to a total draft ranging from 2339 to 6381 lb (10.4 to 28.4 kN).

In heavy secondary or light primary tillage, average draft varied from 90 lb/ft (1.3 kN/m) at 1.6 in (40 mm) depth to 250 lb/ft (3.7 kN/m) at 5 in (125 mm) corresponding to a total draft ranging

from 3829 to 10,635 lb (17.0 to 47.3 kN) for the 42.7 ft (13 m) wide test machine.

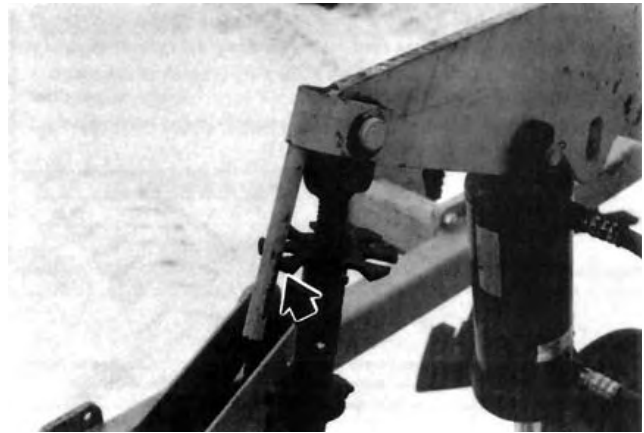

FIGURE 9. Ratchet Jack Lock While Levelling Wings

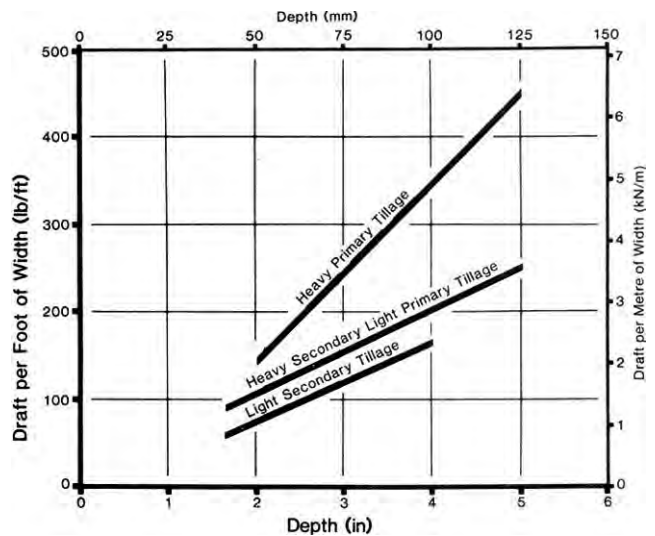

FIGURE 10. Average Draft Requirements for Intermediate Cultivators at 5 mph (8 km/h)

In heavy primary tillage, average draft at 5 mph (8 km/h) varied from 132 lb/ft (1.9 kN/m) at 2 in (50 mm) to 444 lb/ft (6.5 kN/m) at 5 in (125 mm) depth corresponding to a total draft from 5636 to 18,959 lb (24.7 to 84.5 kN) for the 42.7 ft (13 m) wide test unit.

Increasing speed by 1.0 mph increased draft by 10.5 lb/ft (95 N/m draft increase for each 1.0 km/h speed increase). This represents a total draft increase of 448 lbs for a 1.0 mph speed increase (1.1 kN for a 1.0 km/h speed increase) for the test machine in primary tillage.

**Tractor Size:** TABLES 2, 3, and 4 show tractor size required to pull the 42.7 ft (13 m) wide Schulte 300 in light secondary, in heavy secondary or light primary tillage, and in heavy primary tillage with 12 in (305 mm) sweeps.

The power requirements shown for heavy primary tillage are based on draft requirements for heavy duty cultivators with 12 in (305 mm) shank spacings. Tractor size for the Schulte 300 with a 9 in (230 mm) shank spacing may be considerably higher than shown.

Tractor sizes have been adjusted to include tractive efficiency and represent a tractor operating at 80% of maximum power on a level field. The sizes presented in the tables are the maximum power take-off rating, as determined by Nebraska tests or as presented by the tractor manufacturer.

Tractor size may be determined by selecting the desired tillage depth and speed from the appropriate table. For example, in light secondary tillage at 3 in (75 mm) depth and 6 mph (9.7 km/h) a 142 hp (106 kW) tractor is needed to operate the Schulte 300. In heavy secondary or light primary tillage at the same depth and speed, a 200 hp (149 kW) tractor is required. In heavy primary tillage at the same depth and speed, a 252 hp (189 kW) tractor is required.

**TABLE 2.** Tractor Size: Maximum Power Take Off Rating hp (kW) Required to Pull the 427 ft (13 m) Schulte 300 in Light Secondary Tillage

DEPTH in (mm)		SPEED mph (km/h)					
in	(mm)	5	(8.0)	6	(9.7)	7	(11.3)
2	(50)	66	49	93	69	106	79
3	(75)	105	78	142	106	161	121
4	(100)	145	106	191	142	214	160

**TABLE 3.** Tractor Size: Maximum Power Take Off Rating hp (kW) Required to Pull the 427 ft (13 m) Schulte 300 in H caw Secondary Tillage or Light Primary Tillage

DEPTH in (mm)		SPEED mph (km/h)					
in	(mm)	5	(8.0)	6	(9.7)	7	(11.3)
2	(50)	109	81	149	111	176	132
3	(75)	155	115	200	149	239	178
4	(100)	199	148	253	190	304	227
5	(125)	244	182	309	231	361	270

**TABLE 4.** Tractor Size: Maximum Power Take Off Rating hp (kW) Required to Pull the 427 ft (13 m) Schulte 300 in Heavy Primary Tillage

DEPTH in (mm)		SPEED mph (km/h)					
in	(mm)	4	(6.4)	5	(8.0)	6	(9.7)
2	(50)	61	60	112	83	146	109
3	(75)	149	112	198	148	252	189
4	(100)	221	155	285	213	358	268
5	(125)	290	217	371	278	463	346

## OPERATOR SAFETY

Extreme caution is needed in transporting most folding cultivators to avoid contacting power lines. Minimum power line height over farmland or secondary roads varies in the three prairie provinces. In Alberta and Manitoba, lines over roads may be as low as 16 ft (4.8 m). In Saskatchewan, they may be as low as 17 ft (5.2 m). In all three provinces, lines in farmyards may be as low as 15 ft (4.6 m).

Transport height of the 42.7 ft (13 m) three section Schulte 300 test machine was 17.2 ft (5.2 m). This did not permit safe transport under prairie power lines. The legal responsibility for safe passage under utility lines rests with the machine operator and not with the power utility or the machine manufacturer. All provinces have regulations governing maximum permissible equipment heights on various types of public roads. If height limits are exceeded, the operator must contact the power and telephone utilities before moving.

The test machine was 23.9 ft (7.3 m) wide. Caution was required when transporting. A slow moving vehicle sign was supplied. Locks for the centre frame section and the wings were provided. The rigid hitch link and hitch jack allowed safe hitching by one person.

When lifting the wings into transport, the lift cylinder pins bent (see Mechanical History). Failure of a lift cylinder pin, with the wings raised, would allow the wing to drop suddenly. Personal injury and cultivator damage could result. It is recommended that the manufacturer consider modifications to eliminate this problem.

Tires of the Schulte 300 cultivator centre section included a field and highway rating, permitting higher transport speeds. In transport position, the load on the centre section tires exceeded the maximum load ratings by 28% when equipped with fine harrows.

## OPERATOR'S MANUAL

An operator's manual was not available for the Schulte 399 cultivator during the tests. It is recommended that the manufacturer supply an operator's manual for the Schulte 399 cultivator. An operator's manual for the optional mounted harrows was supplied. It contained sufficient information for operation of the harrows.

## MECHANICAL HISTORY

TABLE 4 outlines the mechanical history of the Schulte 399 mid-range cultivator during 183 hours of field operation while tilling 1585 ac (641 ha), and deep banding fertilizer on 1800 ac (730 ha).

The intent of the test was evaluation of functional performance. The following mechanical problems occurred during functional testing. An extended durability test was not conducted.

**TABLE 4.** Mechanical History

ITEM	OPERATING HOURS	EQUIVALENT FIELD AREA	
		ac	(ha)
-Twisted frame for centre section was replaced at	76	1150	(469)
-Bent wing lift cylinder pins were replaced at	50	790	(321)
-Hydraulic leaks were repaired		Throughout the Test	
-Eleven bent shanks were replaced		Throughout the Test	
-Ratchet jack handle on stabilizer wheel was repaired at	85	1310	(530)

**Centre Section Frame:** A diagonal twist in the centre section frame was noted during the first hours of testing. This prevented uniform penetration across the entire cultivator width. The problem was eliminated when the manufacturer replaced the entire centre section frame.

**Wing Lift Cylinder Pins:** The pins at the cylinder end of the wing lift cylinders bent during testing. This occurred while raising the wings into transport position. The manufacturer replaced the pins and installed spacers. This eliminated further bending. It is recommended that the manufacturer consider modifications to prevent bending of the wing lift cylinder pins.

**Shanks:** Eleven shanks were bent during testing. Three shanks bent when they contacted the frame (FIGURE 11). It is recommended that the manufacturer consider modifications to reduce shank bending.

**Ratchet Jack:** The ratchet jack handle on a stabilizer wheel bent when it caught on the stabilizer wheel frame. It is recommended that the manufacturer consider modifications to eliminate this problem.



**FIGURE 11.** Shank Bent After Contacting the Frame.

**APPENDIX I**

**SPECIFICATIONS**

**MAKE:** Schulte  
**MODEL:** 315 42  
**SERIAL NO.:** 3158025507  
  
**MANUFACTURER:** Schulte Industries Ltd  
 P O Box 70  
 Englefeld, Saskatchewan  
 S0K 1N0

	<b>FIELD POSITION</b>	<b>TRANSPORT POSITION</b>
<b>OVERALL DIMENSIONS:</b>		
-width	42.7 ft (13 m)	23.9 ft (7.3 m)
-length (hitch pole extended)		
-with mounted harrows	20 ft (6.1 m)	20 ft (6.1 m)
-height	5.8 ft (1.8 m)	17.2 ft (5.2 m)
-maximum ground clearance	8.7 in (222 mm)	8.7 in (222 mm)
-wheel tread	37 ft (11.3 m)	129 ft (3.9 m)

**SHANKS:**

-number 57  
 -sparing 9 in (230 mm)  
 -trash clearance (frame to sweep tip) 26 in (660 mm)  
 -number of shank rows 4  
 -distance between rows  
     -first and second 27 in (686 mm)  
     -all others 34 in (864 mm)  
 -shank cross section 0.875 x 2 in (22 x 51 mm)  
 -shank stem angle 52 degrees  
 -sweep hole spacing 2.25 in (57 mm)  
 -sweep bolt size 1/2 x 15 in

**HITCH:**

-vertical adjustment range 10 in (254 mm) in 1.25 in (32 mm) increment

**DEPTH CONTROL:**

series hydraulic

**FRAME:**

-cross section 3 x 4 in (75 x 100 mm) tubing

**TIRES:**

-centre section 4, 9 x 15LT, Load range D  
 -wing sections 4, 95L x 15, 6ply  
 -stabilizer wheels 2, 95L x 15, 6ply

**NUMBER OF LUBRICATION POINTS:**

-grease fittings 75  
 -wheel bearings 10

**HYDRAULIC CYLINDERS:**

-depth control  
 1, 4.25 x 8 in (108 x 203 mm)  
 1, 4.5 x 8 in (114 x 203 mm)  
 1, 4.75 x 8 in (121 x 203 mm)  
 1, 5.0 x 8 in (127 x 203 mm)  
  
 -wing lift 2, 4.5 x 24 in (114 x 610 mm)

**WEIGHTS:**

(WITHOUT HARROWS)

	<b>FIELD POSITION</b>	<b>TRANSPORT POSITION</b>
-right wheels	2421 lb (1098 kg)	
-right centre wheels	3444 lb (1562 kg)	5720 lb (2594 kg)
-left centre wheels	3415 lb (1549 kg)	5690 lb (2581 kg)
-left wheels	2380 lb (1080 kg)	
-hitch	<u>1044 lb (473 kg)</u>	<u>1294 lb (587 kg)</u>
TOTAL	12704 lb (5762 kg)	12704 lb (5762 kg)

**WEIGHTS:**

(WITH MOUNTED HARROWS)

	<b>FIELD POSITION</b>	<b>TRANSPORT POSITION</b>
-right wheels	2727 lb (1237 kg)	
-right centre wheels	3890 lb (1764 kg)	6495 lb (2946 kg)
-left centre wheels	3870 lb (1756 kg)	6480 lb (2939 kg)
-left wheels	2710 lb (1229 kg)	
-hitch	<u>908 lb (412 kg)</u>	<u>1130 lb (513 kg)</u>
TOTAL	14105 lb (6398 kg)	14105 lb (6398 kg)

**OPTIONAL EQUIPMENT INCLUDED:**

-mounted finishing harrows (three row) mud scrapers

**OPTIONAL EQUIPMENT AVAILABLE:**

-hitch for anhydrous tank  
 -12 in (305 mm) shank spacing  
 -12 width options from 247 ft (75 m) to 427 ft (130 m)  
 -four row tine harrows

**APPENDIX II**

**MACHINE RATINGS**

The following rating scale is used in Machinery Institute Evaluation Reports:

excellent	fair
very good	poor
good	unsatisfactory

## SUMMARY CHART

### SCHULTE 300 MID-RANGE HEAVY DUTY CULTIVATOR

<b>RETAIL PRICE</b>	\$24,800.00 [February, 1986, f.o.b. Humboldt, 42.7 ft (13.0 m) width, with optional mud scrapers, harrows, and Edwards sweeps].
<b>QUALITY OF WORK</b>	
Shank Characteristics	
-trip clearance	11.7 in (297 mm)
-spring preload	Exceeded at 573 lb/ft (8.4 kN/m), tripping occurred in very heavy primary tillage
-working sweep pitch	2 to 5 degrees over normal tillage
Penetration	
-ability	<b>Very Good</b>
-uniformity	<b>Very Good</b> ; after twisted centre section frame replaced
Trash Clearance	<b>Very Good</b> ; plugging occurred in heavy damp trash
Trash Burial and Field Surface	<b>Good</b> ; harrows left bunches of straw in heavy trash
Weed Kill	<b>Good</b>
<b>EASE OF OPERATION AND ADJUSTMENT</b>	
Hitching	<b>Very Good</b>
Transporting	<b>Fair</b> ; very high transport height
Maneuverability	<b>Very Good</b> ; no interference between hitch and rear tractor tire
Frame Levelling	<b>Good</b>
Depth Adjustment	<b>Very Good</b>
Harrow Adjustment	<b>Good</b>
Sweep and Shank Installation	<b>Very Good</b>
<b>POWER REQUIREMENTS</b>	
Light Secondary Tillage	142 hp (106 kW) at 3 in (75 mm) depth and 6 mph (9.7 km/h)
Heavy Secondary or Light Primary Tillage	200 hp (149 kW) at 3 in (75 mm) depth and 6 mph (9.7 km/h)
Heavy Primary Tillage	252 hp (189 kW) at 3 in (75 mm) depth and 6 mph (9.7 km/h)
<b>OPERATOR SAFETY</b>	Wing lift cylinder pins bent, very high transport height, operator had to climb on frame to position transport locks
<b>OPERATOR'S MANUAL</b>	Not supplied
<b>MECHANICAL HISTORY</b>	Bent wing lift cylinder pins, eleven shanks bent



3000 College Drive South  
Lethbridge, Alberta, Canada T1K 1L6  
Telephone: (403) 329-1212  
FAX: (403) 329-5562  
<http://www.agric.gov.ab.ca/navigation/engineering/afmrc/index.html>

### Prairie Agricultural Machinery Institute

Head Office: P.O. Box 1900, Humboldt, Saskatchewan, Canada S0K 2A0  
Telephone: (306) 682-2555

Test Stations:  
P.O. Box 1060  
Portage la Prairie, Manitoba, Canada R1N 3C5  
Telephone: (204) 239-5445  
Fax: (204) 239-7124

P.O. Box 1150  
Humboldt, Saskatchewan, Canada S0K 2A0  
Telephone: (306) 682-5033  
Fax: (306) 682-5080