

Evaluation Report

196

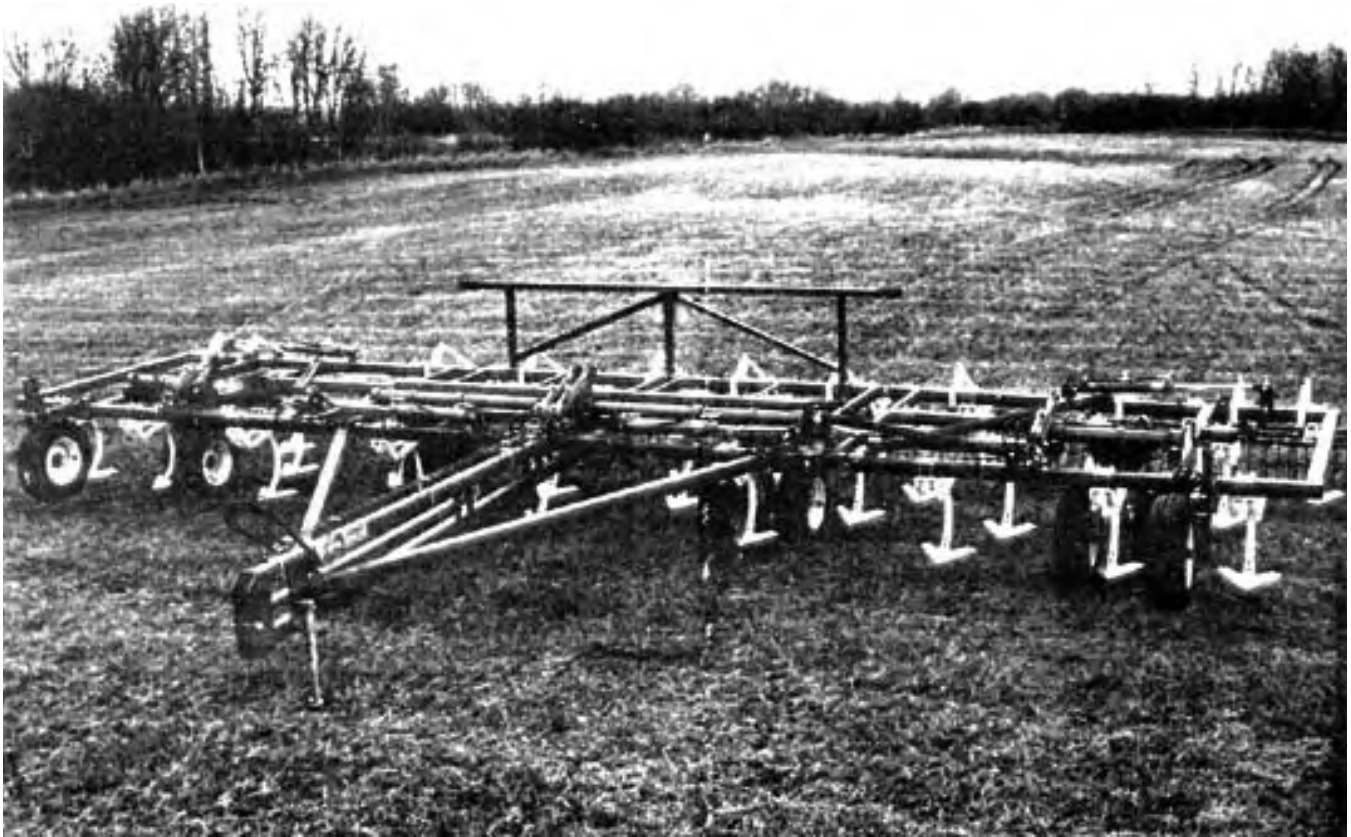

Wil-Rich 13CPW (11.3 m) Heavy Duty Cultivator

A Co-operative Program Between



WIL-RICH 13CPW CHISEL PLOW

MANUFACTURER AND DISTRIBUTOR:

Wil-Rich Inc.
Box 1013
Wahpeton, North Dakota 58075

RETAIL PRICE:

\$14,511.00 (June, 1980, f.o.b. Humboldt, 11.3 m width, with optional hitch jack, finishing harrows, sweeps and 9.5L x 15 tires).

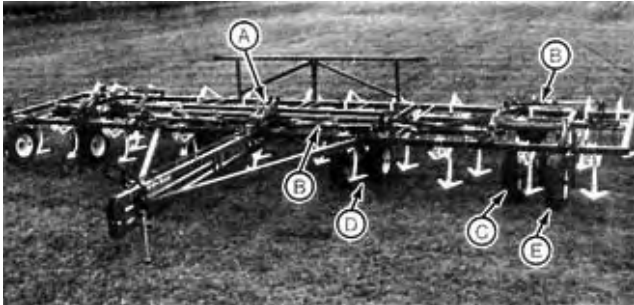

FIGURE 1. Wil-Rich 13CPW: (A) Depth Control Cylinders, (B) Wing Lift Cylinders, (C) Tandem Wing Wheels, (D) Tandem Centre Wheels, (E) Wing Stabilizer Wheels.

SUMMARY AND CONCLUSIONS

The overall functional performance of the Wil-Rich 13CPW heavy duty cultivator was good. Performance was reduced by poor weed kill in some conditions.

The spring cushioned shanks could lift 345 mm (13.6 in) to clear stones. When equipped with sweeps having a 43 degree stem angle, as supplied by the manufacturer, sweep pitch varied from 2 to 6 degrees over the full draft range normally experienced by heavy duty cultivators. With 305 mm (12 in) spacing, shank trip spring preload was exceeded at drafts greater than 7.3 kN/m (500 lb/ft). This is above the range of normal primary tillage drafts.

The Wil-Rich 13CPW had good penetration in most conditions. Depth of penetration was uniform in normal soil conditions. In heavy primary tillage, careful adjustment of depth control and stabilizer wheels was required to achieve acceptable fore-and-aft levelling of the wing tips. Weed kill was fair in normal conditions. Weed kill was reduced because of minimal overlap of four trimmed sweeps on the cultivator. The cultivator skewed significantly on normal side slopes reducing overlap causing weed misses at several locations across the machine. The Wil-Rich 13CPW followed the contour of rolling land well. Trash clearance was very good. In heavy trash, plugging occurred at shanks adjacent to depth control wheels, and at rear shanks because of straw build-up at the mounted harrows. Furrow bottom ridging was not excessive with the 43° sweeps.

The Wil-Rich 13CPW could be conveniently placed into transport position in less than five minutes. The 180 mm (7 in) sweep-to-ground clearance provided sufficient transport ground clearance. The transport wheel tread of 3.1 m (10.2 ft) allowed safe transport on most slopes and rough terrain. The Wil-Rich 13CPW towed well at normal transport speeds. The tires of the centre wheels were not adequately sized to safely support the cultivator with mounted harrows. Transport height of the 11.3 m (37 ft) test machine was 4.2 m (13.8 ft), permitting safe transport under prairie power lines. Transport heights of wider models of the Wil-Rich 13CPW are greater than minimum power line heights.

When equipped with mounted harrows, hitch weight was negative, making hitching inconvenient. The hitch link was free to swivel downward making one-man hitching very difficult. Adequate adjustment was provided for both lateral and fore-aft frame levelling.

Average draft for the 11.3 m (37 ft) wide test machine in light primary tillage at 8 km/h (5 mph) varied from 19.2 kN (4310 lb) at 50 mm (2 in) depth to 42.2 kN (9470 lb) at 125 mm (5 in) depth. In heavy primary tillage at 8 km/h (5 mph), average draft varied from 20.5 kN (4600 lb) at 50 mm (2 in) to

74.1 kN (16,630 lb) at 125 mm (5 in).

In light primary tillage, at 10 km/h (6.2 mph) and 75 mm (3 in) depth, a tractor with 137 kW (184 hp) maximum power-take-off rating will have sufficient power reserve to operate the 11.3 m (37 ft) wide Wil-Rich 13CPW. In heavy primary tillage at the same depth and speed, a 167 kW (224 hp) tractor is needed.

The Wil-Rich 13CPW was equipped with both wing and depth control cylinder transport locks for safe towing. No slow moving vehicle sign was provided. The operator's manual was clear, concise and well illustrated, giving information on operation and maintenance. However, it contained very little safety information.

Some mechanical problems occurred during the 154 hours of field operation. During testing, it was found that one wing frame was deformed, causing frame misalignment. The stabilizer wheels interfered with their mounts. The pivots of 19 shank holders cracked. Two shank holders were damaged by frame interference. One sweep and one shank were damaged by stones. The hitch pivot pin failed. Two depth control cylinder rods bent. Three hydraulic hoses failed. One wheel bearing failed. Two tires were damaged by sweeps. Eight retainer clips for hydraulic cylinder pins were damaged, allowing the pins to come out.

RECOMMENDATIONS

It is recommended that the manufacturer consider:

1. Improving quality control and set up inspection to guard against frame misalignment.
2. Eliminating interference between the stabilizer wheels and their mounts, and strengthening the mount members to maintain wheel alignment during operation.
3. Modifying the shank holders to reduce breakage.
4. Arranging shanks on the cultivator to avoid use of trimmed sweeps adjacent to wheels, and to avoid interference with frame members.
5. Protecting sweep bolts from soil abrasion to allow easy removal.
6. Modifying the hitch pivot pin to reduce breakage.
7. Improving assembly instructions and set up inspection of the wing depth control components to prevent bending of the depth control cylinder rod.
8. Modifications to reduce pin retainer clip failures on the hydraulic cylinders.
9. Supplying tires which comply with the Tire and Rim Association toad rating.
10. Supplying an alternate location for the hitch jack at the rear of the cultivator for use when equipped with mounted harrows.
11. Supplying a device to hold the hitch link in the horizontal position to facilitate one-man hitching.
12. Providing a slow moving vehicle sign as standard equipment.
13. Including adequate safety information in the operator's manual.
14. Working with the agricultural equipment industry to standardize hydraulic quick couplers and hydraulic hose fitting threads.
15. Working with the agricultural equipment industry to standardize shank and sweep stem angles and sweep fastener spacings and sizes.

Chief Engineer -- E. O. Nyborg

Senior Engineer -- J. D. MacAulay

Project Engineer -- D. E. Gullacher

THE MANUFACTURER STATES THAT

With regard to recommendation number:

1. The manufacturer was unaware of damage to the left wing frame that caused deformation of that member and a new wing would have been provided under our warranty policy had we been notified. It is suspected that this wing frame was damaged in handling or shipping prior to dealer assembly. The manufacturer practices a conscientious quality control program.
2. To accommodate several different installations and clearances, the stabilizer wheel axle assemblies are designed so that they can be mounted in six different ways. Alternate mounting

would have eliminated interference. A heavy duty castoring stabilizer wheel is also available.

3. Failures typical to those experienced by PAMI were traced to a vendor supplying inferior tubing material, which once detected, was immediately corrected. The material specifications have been upgraded and the quality control inspection practices tightened.
4. Shank interference with frame members can be avoided by moving the affected shanks laterally by as little as 6 mm (0.25 in). Shank placement practices will be considered on all future major redesigns.
5. Sweep bolts are available in three different lengths to allow customer selection to match sweep size, type and manufacturer. A check of parts currently in stock resulted in complete containment of bolt threads within the nut.
6. Modification of the hitch pivot pin to eliminate breakage is in current production.
7. Steps have been taken to prevent improper assembly of the wing depth control cylinder bracket.
8. Redesigned hydraulic cylinder yoke pins, which prevent damage to the retainer clips, are in production.
9. Various tire sizes and ratings are available from Wil-Rich. Tires and wheels are supplied according to dealer order. We find the tire and rim association ratings to be quite conservative, but refuse dealer requests when the tire overload is severe.
10. An optional rear jack stand assembly is available for use with mounted harrows. Hitching can also be done with the sweeps on the ground.
11. An optional two-bolt heavy duty hitch link is available and facilitates one-man hitching. There has not been adequate demand for a device on the one-bolt hitch link to justify the added cost.
12. Consideration will be given to providing slow moving vehicle sign brackets.
13. A new operator's manual will contain adequate operator safety information.
14. Hydraulic hoses furnished with the cultivator utilize standard J.I.C. 0.375 in ends to fit adapters for male couplers. The customer fits couplers to match tractor specifications.
15. We support updating the current ASAE 255.1 Standard, and in any future design, we would seriously consider following the standard.

NOTE: This report has been prepared using SI units of measurement. A conversion table is given in APPENDIX III.

GENERAL DESCRIPTION

The Wil-Rich 13CPW is a trailing, flexible, three section heavy duty cultivator suitable for medium and heavy primary tillage operations. It is available in 13 widths ranging from 6.4 to 13.7 m (21 to 45 ft). The test machine was an 11.3 m (37 ft) model with a 4.1 m (13.5 ft) centre frame, two 2.7 m (8.9 ft) primary wings, and two 0.9 m (36 in) fold-out extension stubs. It was equipped with 37 spring cushioned shanks, laterally spaced at 305 mm (12 in), arranged on four rows.

The centre frame is carried on two walking tandem wheel sets. Each wing is supported by a walking tandem wheel set and a stabilizer wheel mounted on the front frame member. Four interconnected hydraulic cylinders control tillage depth. The wings fold into upright position with four hydraulic cylinders, connected in parallel. A tractor with dual hydraulic controls and a minimum pressure capability of 13,300 kPa (1930 psi) was needed to operate the test machine. Detailed specifications are given in APPENDIX I while FIGURE 1 shows the location of major components.

SCOPE OF TEST

The Wil-Rich 13CPW was operated in the field conditions shown in TABLE 1, for 154 hours, while cultivating 1278 ha (3200 ac). It was evaluated for quality of work, ease of operation and adjustment, power requirements, safety, and suitability of the operator's manual.

Optional attached finishing harrows were used during the test.

RESULTS AND DISCUSSION

QUALITY OF WORK

Shank Characteristics: There is a large variation in shank and sweep stem angles (FIGURE 2) on cultivators from different manufacturers. Sweeps and shanks must be matched to obtain sufficient sweep pitch to achieve and maintain penetration. Usually manufacturers recommend sweeps with a stem angle from 0 to 5 degrees less than the shank stem angle to result in a slightly positive no load sweep pitch.

Sweep pitch increases in proportion to draft due to shank flexing, and, depending on shank stiffness and cushioning spring preload, may become excessive on some cultivators in normal tillage. A slightly positive sweep pitch results in uniform tillage depth and a smooth furrow bottom while excessive sweep pitch causes furrow bottom ridging, rapid sweep tip wear, and increased draft. Shanks which maintain a low, relatively constant sweep pitch, over the normal range of tillage forces, are desirable.

TABLE 1. Operating Conditions

FIELD CONDITIONS	HOURS	FIELD AREA (ha)
Soil Type		
- light loam	26	216
- loam	100	830
- clay	28	232
TOTAL	184	1278
Stony Phase		
- stone free	24	199
- occasional stones	53	440
- moderately stony	54	448
- very stony	23	191
TOTAL	154	1276

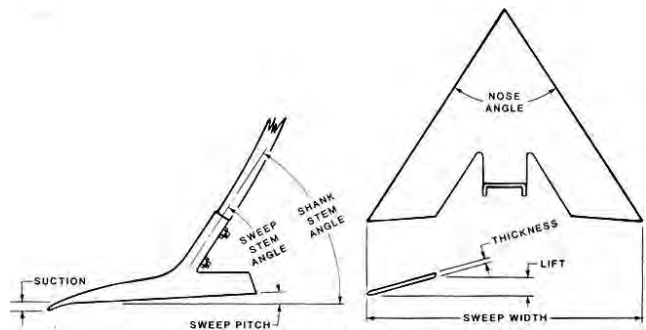

FIGURE 2. Shank and Sweep Terminology.

The Wil-Rich 13CPW was equipped with spring cushioned shank holders. The preload of the springs was adjustable. During the test, the cultivator was used with 406 mm (16 in) wide Adams and Nicols sweeps with 43 degree stem angle. This gave a no load sweep pitch of 2 degrees.

FIGURE 3 shows pitch characteristics of the Wil-Rich 13CPW shank assembly. The low end of the pitch curve results from shank flexing while the steeper part is due to cushioning spring deflection. Sweep pitch varied about 4 degrees over the full range of draft normally occurring in primary tillage. When equipped with 43 degree sweeps, as used during the test, sweep pitch varied from 2 to 6 degrees over the normal draft range. At the manufacturer's recommended setting, shank spring preload was exceeded and tripping occurred at drafts greater than 7.3 kN/m (500 lb/ft), as shown on the graph. Tripping occurred beyond the normal primary tillage draft range, indicating the Wil-Rich 13CPW spring cushioned shanks are adequate for heavy primary tillage.

FIGURE 4 shows the lifting pattern when shanks encounter stones or field obstructions. Maximum lift height was 345 mm (13.5 in). One shank bent and one sweep broke during the 154 hour test period. The spring cushioned shank holders performed well during the test and the failures that occurred do not represent a serious problem.

FIGURE 3. Sweep Pitch Variation over a Normal Range of Draft (305 mm shank spacing).

Penetration: Penetration was very good in normal primary tillage conditions. Positive sweep pitch and cultivator mass of

380 kg/m (250 lb/ft) was sufficient for proper penetration.

Penetration uniformity in normal soil conditions was good across the width of the cultivator, provided the frame was properly levelled and depth control cylinders were kept synchronized. The depth control wheels were positioned so that each centre section wheel supported about 13% of the cultivator weight while each wing supported about 12%.

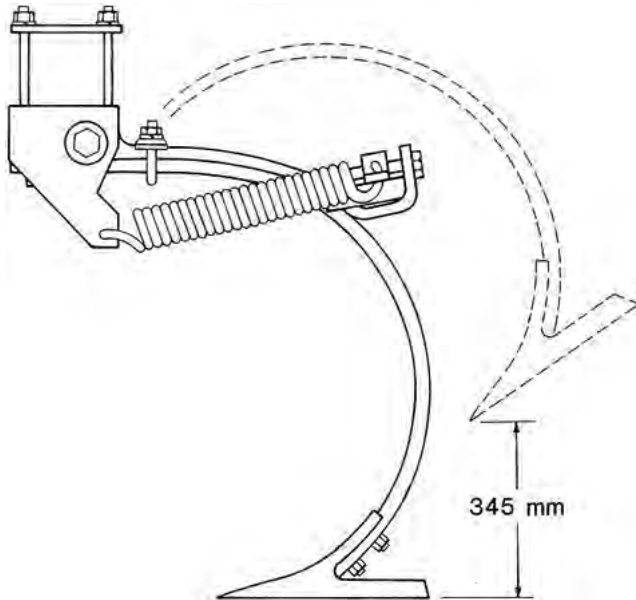

FIGURE 4. Shank Lifting Pattern.

During operation, tillage forces redistributed load on the cultivator wheels so that each centre wheel supported about 10% of total weight while each wing wheel supported about 15%. For good flotation and uniform penetration across the cultivator width, it is desirable to have wheels sized and positioned so that each supports equivalent weight.

Depth differences between the front and rear rows of shanks were slight in normal conditions, once the hitch and stabilizer wheels were properly adjusted to level the frame. The stabilizer wheels were positioned very close to the front frame member and in very heavy draft conditions, the wing frame rotated about the stabilizer wheel axis, reducing the penetration of the rear row of sweeps. Careful adjustment of the stabilizer and depth control wheels was required to bring depth differences between front and rear shank rows within acceptable limits in these conditions.

The Wil-Rich 13CPW followed gently rolling field contours fairly well. The division of the cultivator width into three roughly equal sized hinged sections resulted in fairly uniform penetration across the machine width in rolling fields. As with most wing cultivators, large variations in tillage depth could occur in fields with abrupt contour changes.

Plugging: Trash clearance was very good. In heavy or damp straw conditions, the mounted harrows accumulated straw causing eventual plugging of the rear row of shanks. As well, long damp straw occasionally collected between the depth control wheels and adjacent shanks, also causing plugging.

Trash Burial and Field Surface: When operating at a 75 mm (3 in) tillage depth and fitted with 43° sweeps, the Wil-Rich 13CPW left most stubble standing when travelling at speeds below 6 km/h (4 mph). The amount of trash buried increased appreciably with increased speed. In normal first operation summerfallow, sufficient trash was buried to allow the use of a field cultivator for subsequent tillage.

Trash burial with chisel points in heavy crop residue was good (FIGURE 5). The action of the chisel points moved enough soil for adequate trash burial while leaving some standing stubble for snow retention.

Functional performance of the optional mounted harrows was fair. The harrows were effective in smoothing out surface ridges, leaving a slightly ridged surface condition (FIGURE 6). In heavy trash conditions, the mounted harrows tended to plug easily.



FIGURE 5. Typical Trash Burial with Chisel Points.



FIGURE 6. Typical Field Surface when using Optional Mounted Harrows.

Furrow Bottom Ridging: In normal soil conditions, furrow bottom ridging was 20 mm. In harder soils, ridging increased to 25 mm (1 in) due to shank flex. Also in hard soils, excessive ridging was frequently encountered if the spring cushion setting was not adjusted to a tension above that recommended by the manufacturer.

Skewing and Stability: The Wil-Rich 13CPW skewed considerably on side slopes or in heavy draft conditions where soil varied in hardness across the width of the machine. The sweep pattern (FIGURE 7), however, was symmetrical and did not impose any resultant side forces on the cultivator during normal operation. With 406 mm (16 in) sweeps, as used on 33 of the 37 shanks, the cultivator had to skew more than 2.4° for weed misses to consistently occur across the cultivator width. Trimmed sweeps (FIGURE 8) were used on the 4 shanks adjacent to the wheels, and the cultivator had to skew only minimally for weed misses to occur at these locations. Moderately hilly ground caused sufficient sideways skewing for frequent weed misses by the trimmed sweeps.

It is recommended that shanks be arranged on the cultivator to avoid the use of trimmed sweeps adjacent to wheels.

Weed Kill: Weed kill was fair in normal soil conditions when the cultivator was equipped with 406 mm (16 in) sweeps at a lateral spacing of 305 mm (12 in). Shanks adjacent to the wheels had trimmed sweeps which gave minimal overlap and frequent weed misses occurred during sideways skewing on uneven ground. Sweeps were located behind the depth control wheels to uproot weeds in the wheel tracks.

The finishing harrows were effective in uprooting and exposing weeds loosened by the cultivator. Performance of the harrows was reduced by trash build-up in heavy trash conditions.

EASE OF OPERATION AND ADJUSTMENT

Transporting: The Wil-Rich 13CPW was easily placed into transport position (FIGURE 9) using the hydraulic wing lift system supplied as standard equipment. Transport locks were provided for the wings and the centre section depth control wheels. One man could place the Wil-Rich 13CPW in transport position in less than 5 minutes.

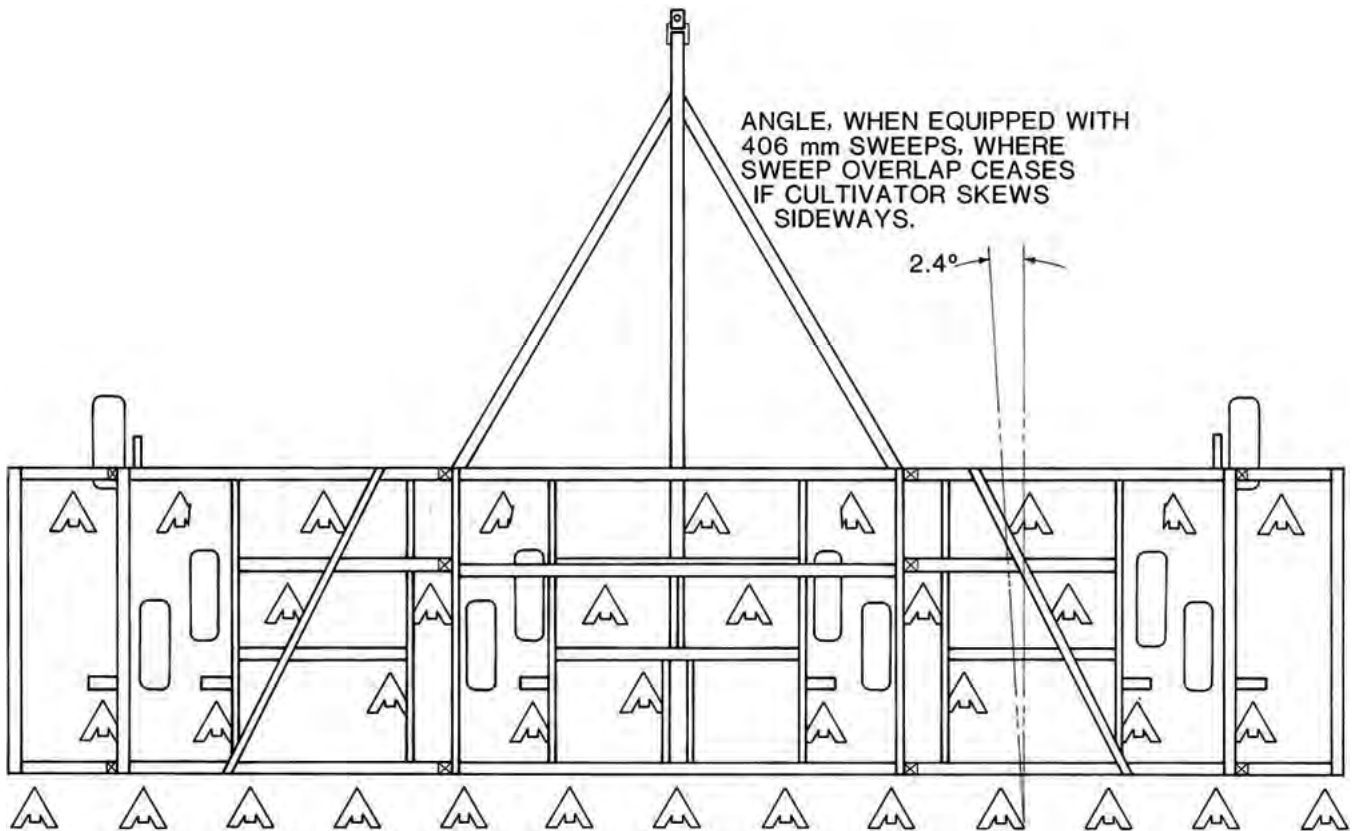

FIGURE 7. Sweep Pattern (305 mm shank spacing).

Transport width was 5.7 m (18.7 ft) while transport height was 4.2 m (13.8 ft). Care was needed when transporting on public roads, through gates, over bridges, and beneath power and telephone lines.

The Wil-Rich towed well without sway at normal transport speeds. Sweep to ground clearance of 180 mm (7 in) and wheel tread of 3.1 m (10 ft) gave good transport ground clearance.



FIGURE 8. Trimmed Sweep.

Hitching: The Wil-Rich 13CPW was equipped with an optional hitch jack, permitting easy hitching if the cultivator was not fitted with mounted harrows. With mounted harrows attached, hitch weight was negative, making it difficult for one man to hitch the cultivator without use of the tractor hydraulics. It is recommended that an alternate location for the hitch jack be provided at the rear of the cultivator to facilitate hitching when equipped with mounted harrows.

The hitch link (FIGURE 10) swivelled downward when not hitched to a tractor, making one man hitching very difficult. It is recommended that a device be provided to hold the link in horizontal position for one man hitching.

Hitch height could be adjusted 305 mm (12 in) in 12 increments by removing one bolt. This range was adequate to allow fore-and-aft

cultivator frame levelling with all tractors used during the test.

Maneuverability: The hitch pole on the Wil-Rich 13CPW was narrow, allowing normal turns without tractor wheel interference. The walking tandem wheels skidded slightly during normal turns.

The wing stabilizer wheels can be attached at any location along the front wing members. Care should be taken, however, that these wheels are not attached to the extension stubs, as lateral forces on the wheels when turning will cause the stubs to rise out of the ground.

There was sufficient overhang beyond the wing wheel set to allow moderate overlap without running these wheels on cultivated ground. This ensures proper flotation and aids in uniform penetration.

Frame Levelling: Adequate lateral levelling adjustment was provided on the cultivator. The wing sections were levelled to the centre section height by adjusting the wing depth control cylinder mounting brackets.

Depth of Tillage: Tillage depth was adjusted with four interconnected hydraulic cylinders. Two master cylinders, operated by the tractor hydraulics, controlled a common rockshaft on the centre section, and a slave cylinder on each wing. As with most master-slave combinations, periodic synchronization of the cylinders, by fully extending them, was necessary. Adjustable collars on the cylinder shafts were used to set tillage depth.

When the wing stabilizer wheels were mounted on the extension stubs, frequent lifting of the extensions occurred.

Sweep Installation: It took one man about 3 hours to replace the 37 sweeps on the Wil-Rich 13CPW. The 180 mm (7 in) sweep ground clearance was adequate for easy sweep removal. The sweep bolts protruded beyond the nuts, causing thread damage by soil abrasion. This damage made removal difficult. Four new sweeps required trimming for placement on shanks adjacent to the depth control wheels. It is recommended that the sweep bolts be protected from abrasion to allow easy removal.

Shank Installation: Individual shanks could be replaced in less than 10 minutes by removing one u-bolt and one bolt.

POWER REQUIREMENTS

Draft Characteristics: FIGURE 11 shows draft requirements for heavy duty cultivators in typical primary tillage, at a speed of

8 km/h (5 mph). This figure gives average requirements based on tests of 10 makes of heavy duty cultivators in 40 different field conditions. Attempting to compare draft requirements of different makes of heavy duty cultivators usually is unrealistic. Draft requirements for the same cultivator, in the same field, may vary by as much as 30% in two different years, due to changes in soil conditions. Variation in soil conditions affect draft much more than variation in machine make, usually making it impossible to measure any significant draft differences between different makes of heavy duty cultivators.

In light primary tillage, average draft per metre of width, at 8 km/h (5 mph), varied from 1.7 kN (11 5 lb/ft) at 50 mm (2 in) depth to 3.7 kN (250 lb/ft) at 125 mm (5 in) depth. For the 11.3 m (37 ft) wide Wil-Rich 13CPW, this corresponds to a total draft ranging from 19.2 to 42.2 kN (4310 to 9470 lbs).

In heavy primary tillage, average draft per metre of width, at 8 km/h (5 mph), varied from 1.8 kN (123 lb/ft) at 50 mm (2 in) depth to 6.5 kN (440 lb/ft) at 125 mm (5 in) depth, corresponding to a total draft from 20.5 to 74.1 kN (4600 to 16,600 lb) for the 11.3 m (37 ft) test machine.

Increasing speed by 1 km/h (0.6 mph), increased draft by about 90 N per metre of width (6 lb/ft). For the 11.3 m (37 ft) wide test machine, this represents a draft increase of 1.0 kN (225 lb) for a 1 km/h (0.6 mph) speed increase.

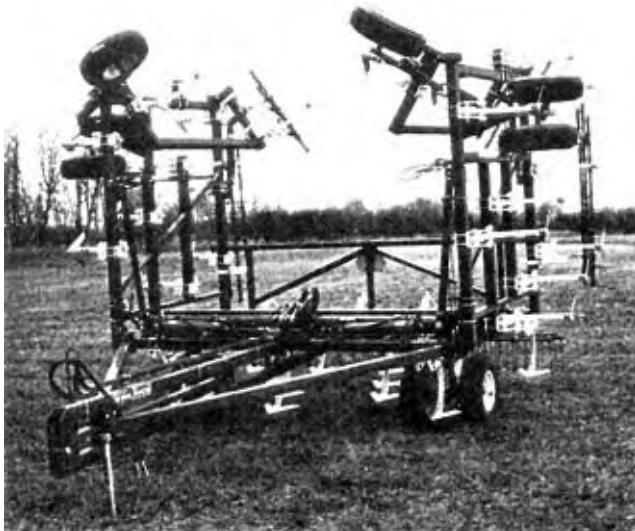

FIGURE 9. Transport Position.

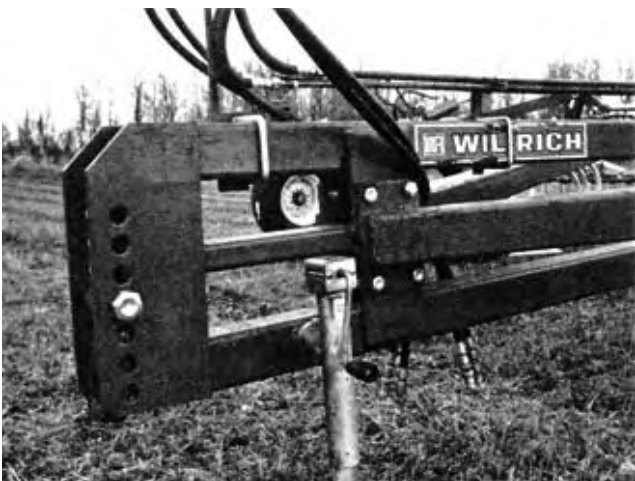

FIGURE 10. Hitch Link in Vertical Position.

Tractor Size: TABLES 2 and 3 show tractor sizes needed to operate the 11.3 m (37 ft) wide Wil-Rich 13CPW in light and heavy primary tillage. Tractor sizes have been adjusted to include tractive efficiency and represent a tractor operating at 80% of maximum power on a level field. The sizes presented in the tables are the maximum power take-off rating, as determined by Nebraska tests or

as presented by the tractor manufacturer. Selected tractor sizes will have ample power reserve to operate the Wil-Rich 13CPW in the stated conditions.

Tractor size may be determined by selecting the desired tillage depth and speed from the appropriate table. For example, in light primary tillage at 75 mm (3 in) depth and 10 km/h (6 mph), a 137 kW (184 hp) tractor is needed to operate the Wil-Rich 13CPW. In heavy primary tillage, at the same depth and speed, a 167 kW (224 hp) tractor is needed.

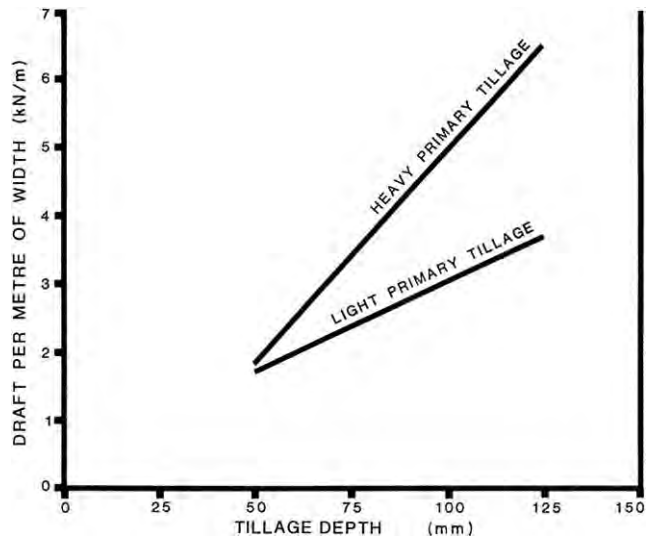

FIGURE 11. Average Draft Requirements for Heavy Duty Cultivators at 8 km/h.

TABLE 2. Tractor Size (Maximum Power Take-off Rating kW) to Operate the 11.3 m Wide Wil-Rich 13CPW in Light Primary Tillage.

DEPTH (mm)	SPEED (km/h)					
	7	8	9	10	11	12
50	59	72	86	100	116	132
75	85	101	119	137	156	177
100	111	131	152	174	197	221
125	137	160	185	211	236	265

TABLE 3. Tractor Size (Maximum Power Take-off Rating kW) to Operate the 11.3 m Wide Wil-Rich 13CPW in Heavy Primary Tillage.

DEPTH (mm)	SPEED (km/h)					
	7	8	9	10	11	12
50	55	67	80	93	108	123
75	108	127	147	162	189	212
100	160	186	213	242	271	301
125	211	245	280	315	362	390

OPERATOR SAFETY

Extreme caution is needed in transporting most folding cultivators to avoid contacting power lines. In Saskatchewan, the energized line may be as low as 5.2 m (17 ft) over farm land or over secondary roads. In Alberta and Manitoba, the neutral ground wire may be as low as 4.8 m (16 ft) over farm land. In all three provinces, lines in farmyards may be as low as 4.6 m (15 ft).

Transport height of the 11.3 m (37 ft) wide test machine was 4.2 m (13.8 ft) permitting safe transport under prairie power lines. Other Wil-Rich cultivators in the 13CPW series, with 3.7 m (12 ft) wide wings, may be high enough for contact with many prairie power lines. The legal responsibility for safe passage under utility lines rests with the machinery operator and not with the power utility or the machinery manufacturer. All provinces have regulations governing maximum permissible equipment heights on various types of public roads. If height limits are exceeded, the operator must contact power and telephone utilities before moving.

The test machine was 5.7 m (18.7 ft) wide in transport position, necessitating caution when transporting.

The hitch link of the Wil-Rich 13CPW swivelled downward when not hitched to a tractor. In the process of hitching, a safety hazard exists when a person holds the hitch link, while the operator moves the tractor into position. This hazard could be eliminated by use of a device to hold the hitch link in a horizontal position. It is

recommended that the manufacturer supply as standard equipment, a device to hold the hitch link in a horizontal position.

Wing and depth control transport locks were provided. Danger areas should be avoided when climbing onto the implement to fasten these locks.

No slow moving vehicle sign or mounting bracket was provided. It is recommended that a slow moving vehicle sign be supplied as standard equipment.

The tires of the cultivator in transport position, without mounted harrows, were adequate for speeds up to 32 km/h (20 mph). The load on these tires when the cultivator was fitted with mounted harrows exceeded the maximum load recommended by the Tire and Rim Association for the tires supplied with the machine. It is recommended that the manufacturer select tires for the centre wheels in accordance with the standards of The Tire and Rim Association Inc., for use with mounted harrows.

STANDARDIZATION

Hydraulics: During the test, considerable difficulty was encountered due to differences in hydraulic couplers on various tractors. The difficulty was in the lack of standardization both in couplers and in hose threads. More standardization is needed in this area.

Sweep Bolt Holes: The bolt hole size and spacing on cultivator sweeps and shanks, as well as stem angles, should similarly be standardized to provide some degree of interchangeability of sweeps.

OPERATOR'S MANUAL

The operator's manual supplied instructions on setup, operation, and maintenance of the cultivator. Very little safety information was included in the operator's manual. It is recommended that information regarding the safe operation of the cultivator be included in the operator's manual.

DURABILITY RESULTS

TABLE 4 outlines the mechanical history of the Wil-Rich 13CPW during 154 hours of field operation while tilling about 1278 ha (3200 ac). The intent of the test was evaluation of functional performance. The following mechanical problems represent those which occurred during functional testing. An extended durability evaluation was not conducted.

TABLE 4. Mechanical History

ITEM	OPERATING HOURS	EQUIVALENT FIELD AREA (ha)
Frame:		
-The stabilizer wheel members flexed during operation causing moderate wheel misalignment		Throughout the Test
-Eight retainer clips on the depth control cylinder pins sheared and were replaced at	40, 107	332, 888
-The hitch pivot bolt broke and was replaced at	154	1278
-One wing frame was observed to be twisted at		Near the End of Test
Shank and Holder:		
-Two shank holders interfered with frame members		Throughout the Test
-A sweep broke while clearing a stone and was replaced at	29, 60	3560, 498
-19 shank holder pivots were observed to be cracked at		End of Test
-A shank bent while clearing a stone and was replaced at	114	946
Hydraulic System:		
-Two hydraulic hoses on the depth control system burst and were replaced at	18, 51	149, 423
-Two depth control cylinder rods were observed to be slightly bent at	40	332
-A hydraulic hose on the wing lift system burst and was replaced at	40	332
Wheels:		
-Three tires were damaged at	18, 33, 98	149, 274, 813
-One wheel bearing failed at	154	1278

DISCUSSION OF MECHANICAL HISTORY

Stabilizer Wheels: The stabilizer wheel mount twisted during operation, resulting in moderate wheel misalignment (FIGURE 12). It is recommended that the stabilizer wheel mount stub be strengthened to retain proper wheel alignment during operation.

The stabilizer wheels rubbed on their mounts during operation. It is recommended that the stabilizer axles be extended to give

adequate clearance between the wheels and mounts.



FIGURE 12. Stabilizer Wheel Mount Stub.

Pin Retainer Clips: Retainer clip damage was caused by forced rotation of the cylinder pins during operation (FIGURE 13). It is recommended that the pins be firmly anchored in the cylinder yokes to prevent clip damage from rotation.



FIGURE 13. Damaged Retainer Clips on Cylinder Yokes.

Hitch Pivot Bolt: The hitch pivot bolt failed at the thread root at the base of the threaded section. It is recommended that the bolt be modified to prevent breakage.

Wing Frame: It was found near the end of the test that the left wing frame was deformed so that the rear wing frame member was about 50 mm (2 in) lower than the front. It was concluded that the misalignment occurred either in manufacturing or during transport before assembly. It is recommended that the manufacturer improve quality control and set up inspection.

SHANK AND HOLDER

Shank Interference: When positioned according to the manufacturer's recommendations, shanks on both wings, when tripped, interfered with diagonal frame members, causing shank holder damage (FIGURE 14). It is recommended that the shanks and frame members be positioned to avoid interference.

Sweep and Shank Failures: The shank and sweep failures occurred while operating in very stony conditions. The cushioning springs gave good shank and sweep protection and these failures do not represent a serious problem.

Shank Holder Pivot Failures: The pivots of 19 shank holders cracked as shown in FIGURE 15. It is recommended that the pivots be strengthened to prevent such breakage.

HYDRAULIC SYSTEM

Hose Failures: The hydraulic hose failures that occurred were due mainly to improper joints between hoses and the metal connectors. These failures do not represent a serious problem.

Hydraulic Cylinder Rods: The rods on the wing depth control cylinders were bent at the yoke end. This was caused by improper

assembly of the cylinder mounting bracket which resulted in the yoke interfering with the rock shaft crank arm when the cylinder was extended. It is recommended that steps be taken to prevent this assembly error, and that set up inspection be improved.

WHEELS

Tire Damage: One tire was damaged by striking an object during transport. The other two tires, on outer wheels of the centre section tandem sets, were punctured by sweeps during sideways movement of the sweeps when encountering stones. It is recommended that adequate clearance be given between wheels and sweeps to prevent tire damage.

Wheel Bearing: A wheel bearing in a centre section depth control wheel failed during operation. This failure does not represent a serious problem.

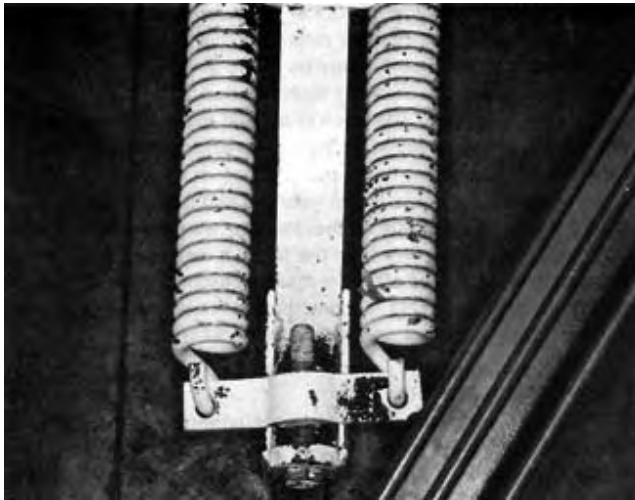

FIGURE 14. Shank Holder Interference with Frame.

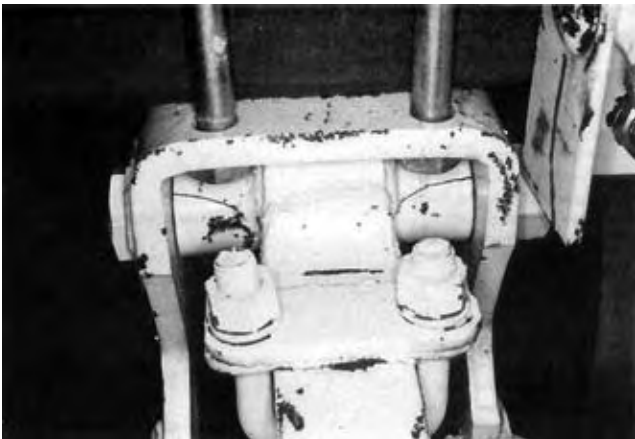

FIGURE 15. Shank Holder Pivot Failures.

APPENDIX I**SPECIFICATIONS**

MAKE: Wil-Rich Chisel Plow

MODEL: 13CPW (11,3 m size)

SERIAL NUMBER: 1715

MANUFACTURER: Wil-Rich Inc.

Box 1013

Wahpeton, North Dakota 58075

DIMENSIONS:	FIELD POSITION	TRANSPORT POSITION
-width	11,370 mm	5700 mm
-length-with harrows	7610 mm	7610 mm
-height	1870 mm	4220 mm
-maximum ground clearance	180 mm	180 mm
-wheel tread	8515 mm	3050 mm

SHANKS:

- number	37
-lateral spacing	305 mm
-trash clearance (frame to sweep tip)	660 mm
-number of shank rows	
-centre section	4
-wings	4
-distance between rows	
-first-second	760 mm
-second-third	760 mm
-third-fourth	860 mm
-shank cross section	25 x 50 mm
-shank stem angle	45
-sweep hole spacing	55 mm
-sweep bolt size	1/2" x 1-7/8"

HITCH:

-vertical adjustment range	305mm
----------------------------	-------

DEPTH CONTROL:

hydraulic

FRAME:

102 mm, 6.4 and 4.8 mm, 4 mm thick, square tubing

TIRES:

-centre section	4, 9.5L x 1.5, 6 ply
-wings	4, 9.5L x 15, 6 ply
-wing stabilizers	2, 9.5L x 15, 6 ply

NUMBER OF LUBRICATION POINTS:

10 grease fittings, daily service
 10 grease fittings, weekly service
 10 wheel bearings, yearly service
 4 hub assemblies, yearly service

HYDRAULIC CYLINDERS:

-depth control	
-centre section	2, 102 x 236 mm
-wings	2, 102 x 203 mm
-wing lift	
-primary wings	2, 102 x 610 mm
-extension stubs	2, 76 x 610 mm

WEIGHTS:

(Without Harrows)	FIELD POSITION	TRANSPORT POSITION
-right wheel	986 kg	
-right centre wheels	1093 kg	2068 kg
-left centre wheels	1072 kg	2104 kg
-left wheel	1044 kg	
-hitch	95 kg	118 kg
TOTAL	4290 kg	4290 kg

WEIGHTS:

(With Mounted Harrows)	FIELD POSITION	TRANSPORT POSITION
-right wheels	1120 kg	
-right centre wheels	14.20 kg	2457 kg
-left centre wheels	1322 kg	2457 kg
-left wheels	1112 kg	
-hitch	-303 kg	-243 kg
TOTAL	4.671 kg	4.671 kg

OPTIONAL EQUIPMENT:

-13 width options from 6 4.00 mm to 13,720 mm
 -mounted finishing harrows
 -hitch pole jack shank options
 -3 tire size options

APPENDIX II**MACHINE RATINGS**

The following rating scale is used in PAMI Evaluation Reports:

(a) excellent	(d) fair
(b) very good	(e) poor
(c) good	(f) unsatisfactory

APPENDIX III**CONVERSION TABLE**

1 hectare (ha)	= 2.5 acre (ac)
1 kilometre/hour (km/h)	= 0.6 miles/hour (mph)
1 millimetre (mm)	= 0.04 inches (in)
1 metre (m)	= 3.3 feet (ft)
1 kilowatt (kW)	= 1.3 horsepower (hp)
1 kilogram (kg)	= 2.2 pounds mass (lb)
1 kilonewton (kN)	= 220 pounds force (lb)
1 kilonewton/metre (kN/m)	= 70 pounds force/foot (lb/ft)
1 kilopascal (kPa)	= 0.2 pounds force/square inch (psi)



3000 College Drive South
 Lethbridge, Alberta, Canada T1K 1L6
 Telephone: (403) 329-1212
 FAX: (403) 329-5562
<http://www.agric.gov.ab.ca/navigation/engineering/afmrc/index.html>

Prairie Agricultural Machinery Institute

Head Office: P.O. Box 1900, Humboldt, Saskatchewan, Canada S0K 2A0

Telephone: (306) 682-2555

Test Stations:

P.O. Box 1060

Portage la Prairie, Manitoba, Canada R1N 3C5

Telephone: (204) 239-5445

Fax: (204) 239-7124

P.O. Box 1150

Humboldt, Saskatchewan, Canada S0K 2A0

Telephone: (306) 682-5033

Fax: (306) 682-5080