

Evaluation Report

153

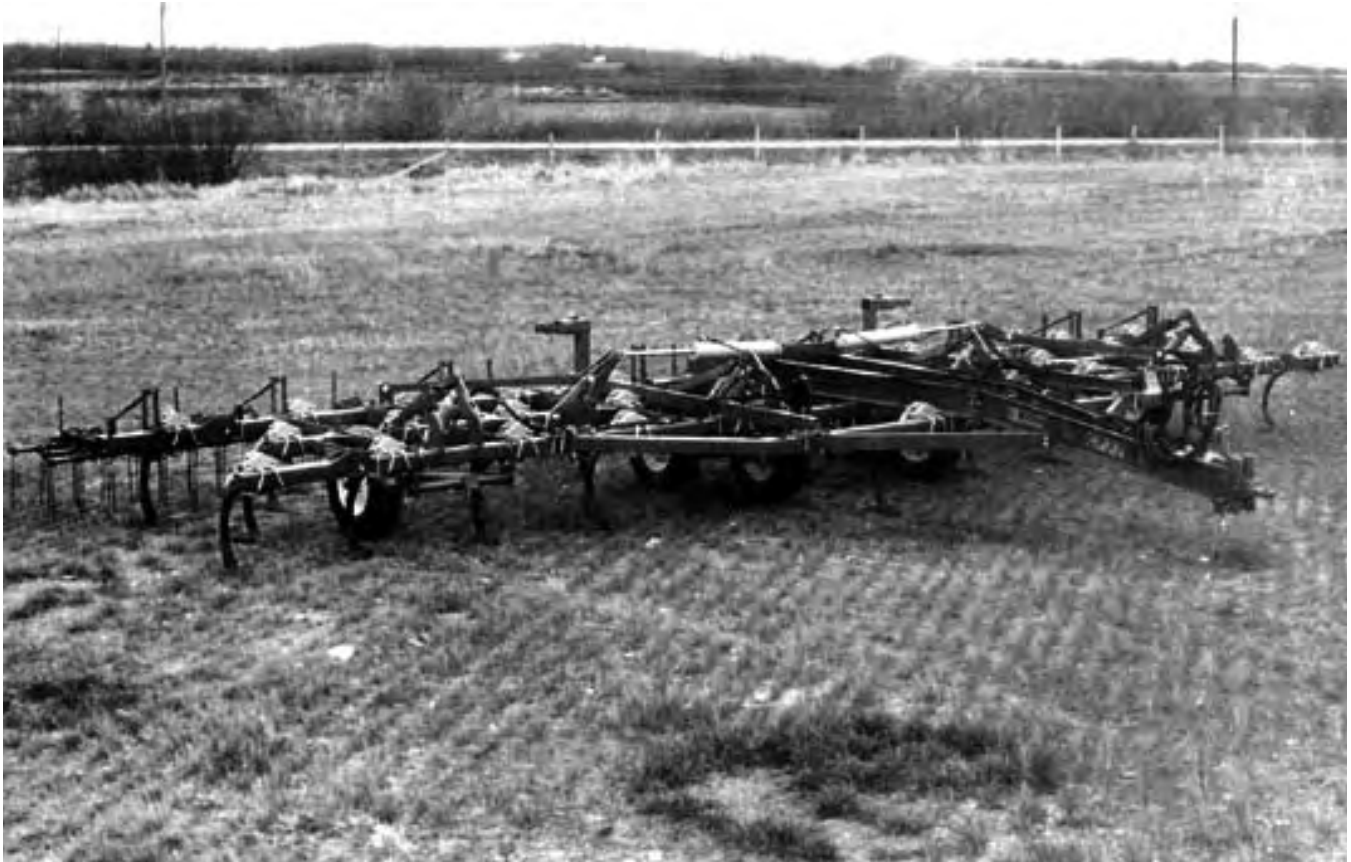

Leon CP77-334 (10.4 m) Chisel Plow

A Co-operative Program Between



LEON CP77-334 CHISEL PLOW

MANUFACTURER AND DISTRIBUTOR:

Leon's Manufacturing Co. Ltd.
135 York Road East
Yorkton, Saskatchewan
S3N 2X3

RETAIL PRICE:

\$10,478.00 (May, 1979, f.o.b. Humboldt, 10.4 m width, with optional finishing harrows).

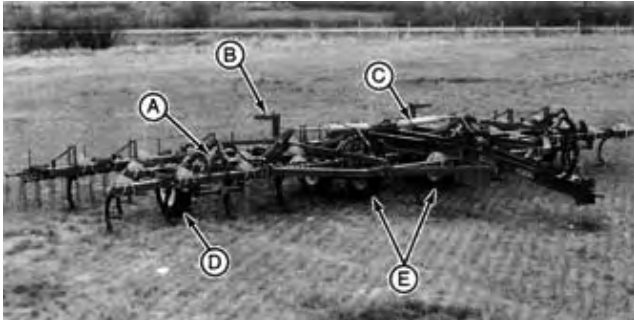

FIGURE 1. Leon CP77-334: (A) Depth Control Cylinders, (B) Wing Safety Stops, (C) Wing Lift Cylinders, (D) Wing Wheels, (E) Centre Wheels.

SUMMARY AND CONCLUSIONS

The overall functional performance of the Leon CP77-334 heavy duty cultivator was good. Performance was reduced by skewing and by uneven penetration in hard soils.

The spring trip shanks could lift 225 mm (8.9 in) to clear stones. When equipped with sweeps, having a 51 degree stem angle, as supplied by the manufacturer, sweep pitch varied from minus 5 to 0 degrees over the full draft range normally experienced by heavy duty cultivators. With 305 mm (12 in) spacing, shank trip spring preload was exceeded at drafts greater than 9.3 kN/m (651 lb/ft) occurring well beyond the range of normal primary tillage drafts.

The Leon CP77-334 penetrated readily in all conditions. Depth of penetration was uniform in normal soil conditions. In heavy primary tillage, at tillage depths greater than 100 mm, the wing tips penetrated about 90 mm deeper than the centre section due to wing wheel sinkage and tire squash, wing frame twist also caused non-uniform fore-and-aft penetration in heavy primary tillage. The Leon CP77-334 was quite unstable and skewed significantly on hillsides and in non-uniform soil conditions, resulting in some weed misses. Weed kill was good on level uniform soil. The Leon CP77-334 followed the contour of rolling land very well. The Leon CP77-334 was capable of clearing heavy trash. In extreme conditions, occasional plugging occurred at shanks adjacent to the depth control wheels. Furrow bottom ridging was only slight with 51 degree sweeps.

The Leon CP77-334 could be conveniently placed into transport position in less than five minutes. The 200 mm (8 in) sweep-to-ground clearance, gave ample transport ground clearance. The narrow 1.7 m (5.6 ft) transport wheel tread made it necessary to take care during turns, or when transporting on slopes or rough ground, to prevent possible upset. The Leon CP77-334 towed well at normal transport speeds. Tires of the optional tandem centre wheels were adequately sized to safely support transport loads. The 10.4 m (34 ft) wide test machine had a transport height of 4.4 m (14.4 ft) permitting safe transport under power lines in the three prairie provinces. Transport heights of some of the wider models of the cultivator are greater than minimum power line heights.

The hitch jack and rigid hitch link made one man hitching easy. Adequate adjustment was provided for both lateral and fore-and-aft frame levelling.

Average draft for the 10.4 m (34 ft) wide test machine, in light primary tillage, at 8 km/h (5 mph) varied from 17.7 kN (3 973 lb) at 50 mm (2 in) depth to 38.5 kN (8643 lb) at 125 mm (5 in) depth. In heavy primary tillage at 8 km/h (5 mph), average draft varied from 18.7 kN (4198 lb) at 50 mm (2 in) to 67.6 kN (15,176 lb) at 125 mm (5 in).

In light primary tillage, at 10 km/h (6.2 mph) and 75 mm (3 in) depth, a tractor with 125 kW (168 hp) maximum power take-off rating will have sufficient power reserve to operate the 10.4 m (34 ft) wide Leon CP77-334. In heavy primary tillage, at the same depth and speed, a 153 kW (205 hp) tractor is needed.

The Leon CP77-334 was equipped with both wing and depth control cylinder transport locks for safe towing. No slow moving vehicle sign was provided. The operator's manual was clear, concise, and well illustrated.

Some mechanical problems occurred during the 210 hours of field operation. The frame extension stubs deformed. One shank bent and several trip mechanisms wore, necessitating replacement of certain parts. Four shank assembly U-bolts broke.

RECOMMENDATIONS

It is recommended that the manufacturer consider:

1. Supplying tandem centre wheels as standard equipment.
2. Modifying the wheel transport lock to avoid interference with the depth control valve.
3. Using more functional wing transport pin retainer clips.
4. Providing a slow moving vehicle sign.
5. Using proper length pins and modified release shoes complete with bushings, on the shank trip assemblies.
6. Shimming all shank trip base blocks during assembly, to properly fit the cultivator frame.
7. Modifying the grease fittings to prevent field loss of fittings.
8. Working with the agricultural equipment industry to standardize hydraulic quick couplers and hydraulic hose fitting threads.
9. Working with the agricultural equipment industry to standardize shank and sweep stem angles, and sweep fastener spacings and sizes.

Chief Engineer - E. O. Nyborg

Senior Engineer - L. G. Smith

Project Engineer - D. E. Gullacher

THE MANUFACTURER STATES THAT

With regard to recommendation number:

1. Tandem centre frame wheels are now supplied as standard equipment.
2. Modifications have been made to eliminate interference of the wheel transport lock with the depth control valve.
3. Design of more functional wing transport pins and retainer clips has been done.
4. Slow moving vehicle signs will be provided on all future machines.
5. Pins of proper length are now being used on all trip assemblies. The problem with release shoes was traced to improperly cored castings. On current production, the alignment problem is corrected and closer quality control is being given to this item.
6. Trip base block castings have been modified to include positioning lugs both above and below frame tubing. Shims are no longer necessary.
7. Grease fittings will be changed to threaded type.
8. Leon's will cooperate to whatever degree is possible.
9. Leon's will cooperate to whatever degree is possible.

GENERAL DESCRIPTION

The Leon CP77-334 is a trailing, flexible, three-section heavy duty cultivator suitable for medium and heavy primary tillage operations. It is available in 15 widths ranging from 7.3 to 13.1 m. The test machine was a 10.4 m model, with a 3.4 m centre frame and two 3.5 m wings. It was equipped with 34 spring-trip shanks, laterally spaced at 305 mm, arranged in three rows on the wings, with an optional four row arrangement on the centre section.

The centre frame is carried on two optional tandem wheel sets, while each wing is supported by a single wheel. Four hydraulic cylinders, connected in series, control the tillage depth. The wings fold into upright position, with two hydraulic cylinders, connected in parallel. Detailed specifications are given in APPENDIX I while FIGURE 1 shows the location of major components.

SCOPE OF TEST

The Leon CP77-334 was operated in the field conditions shown in TABLE 1, for 210 hours, while cultivating about 1387 ha. It was

evaluated for quality of work, ease of operation and adjustment, power requirements, safety and suitability of the operator's manual.

Optional attached finishing harrows were used during most of the test.

TABLE 1. Operating Conditions

FIELD CONDITIONS	HOURS	FIELD AREA (ha)
Soil Type		
- loam	80	528
- sandy loam	2	13
- clay	128	846
TOTAL	210	1387
Stony Phase		
- stone free	106	699
- occasional stones	74	489
- moderately stony	24	159
- very stony	6	40
TOTAL	210	1387

RESULTS AND DISCUSSION

QUALITY OF WORK

Shank Characteristics: There is a large variation in shank and sweep stem angles (FIGURE 2) on cultivators from different manufacturers. Sweeps and shanks must be matched to obtain sufficient sweep pitch to achieve and maintain penetration. Usually manufacturers recommend sweeps with a stem angle from 0 to 5 degrees less than the shank stem angle to result in a slightly positive no load sweep pitch.

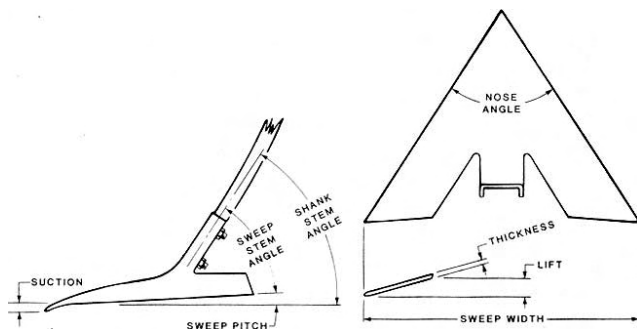

FIGURE 2. Shank and Sweep Terminology.

Sweep pitch increases in proportion to draft due to shank flexing and, depending on shank stiffness and trip spring preload, may become excessive in normal tillage, on some cultivators. A slightly positive sweep pitch results in uniform triage depth and a smooth furrow bottom while excessive sweep pitch causes furrow bottom ridging and rapid sweep tip wear. Shanks which maintain a relatively constant sweep pitch, over the normal range of tillage forces, are desirable.

The Leon CP77-334 was equipped with spring-trip shank holders. Tripping force was adjustable. During the test, the Leon CP77-334 was used with 406 mm wide Mackay sweeps with 51 degree stem angle, as supplied by the manufacturer, giving a no load sweep pitch of minus 5 degrees.

FIGURE 3 shows pitch characteristics of the Leon CP77-334 shank assembly. The low end of the pitch curve results from shank flexing. Sweep pitch varied about 5 degrees over the full range of draft normally occurring in primary tillage. When equipped with 51 degree sweeps, as used during the test, sweep pitch varied from minus 5 to 0 degrees over this draft range. At the manufacturer's setting, the shank trips began to release and shank force decreased at drafts greater than 9.3 kN/m, as shown on the graph. Tripping occurred well beyond the normal draft range, indicating that the Leon CP77-334 was well suited for heavy primary tillage.

FIGURE 4 shows the lifting pattern when shanks encounter stones or field obstructions. Maximum lift height was 225 mm. The shanks were mounted with rubber cushions to reduce recoil shock and to allow sideways sweep movement around obstructions. The shank trip assembly performed well during the test. One shank bent during the 210 hour test period.

Penetration: Penetration was very good in all conditions. In spite of negative sweep pitch, when used with the manufacturer's

recommended sweeps, the large cultivator mass of 380 kg/m was sufficient to achieve very good penetration.

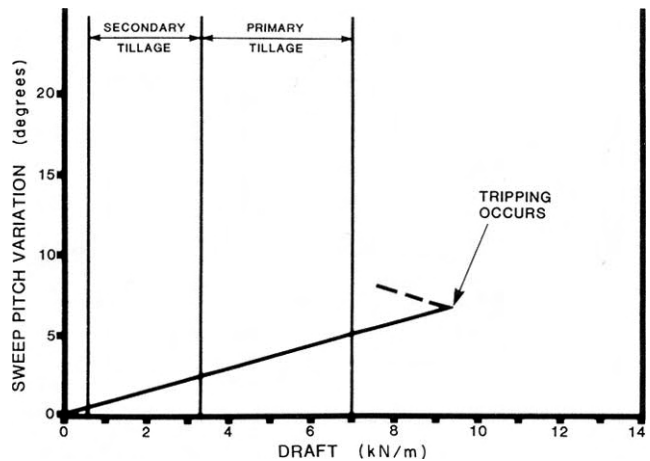

FIGURE 3. Sweep Pitch Variation over a Normal Range of Draft (305 mm shank spacing).

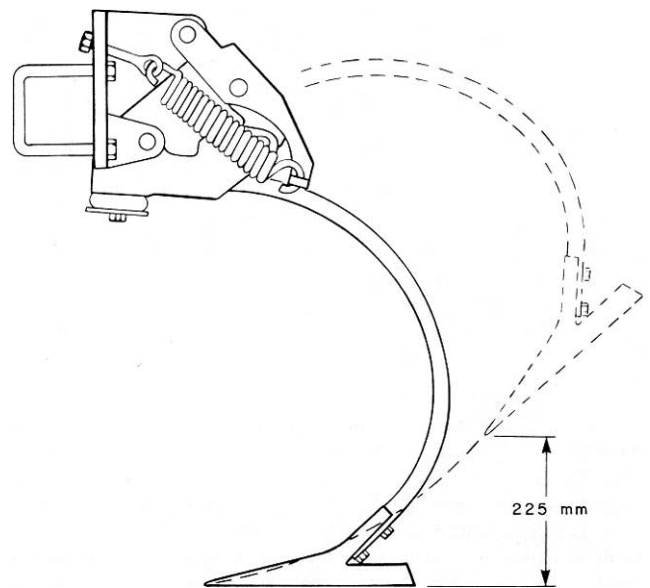

FIGURE 4. Shank Lifting Pattern.

Penetration was uniform across the cultivator width, in normal soil conditions, provided the frame was properly levelled and the depth control cylinders were kept synchronized. In heavy primary tillage, wing wheel sinkage and tire squash caused the wing tips to penetrate about 90 mm deeper than the centre section (FIGURE 5). In these conditions uniform penetration could be maintained only at tillage depth less than 100 mm. The wheels were positioned so that each centre section wheel supported about 17.5% of the cultivator weight while each wing wheel supported 15%. In addition, each centre section wheel supported about 12% of total tillage suction force while each wing wheel supported about 26%. For good flotation and uniform tillage depth across the cultivator width, it is desirable to have wheels sized and positioned so that each supports equivalent weight and similar tillage suction force. Use of the optional tandem wing wheels would probably have greatly improved penetration uniformity in heavy primary tillage by reducing the tillage suction force supported by each wing wheel.

Depth differences between the front and rear rows of shanks were slight in normal soil conditions, once the frame had been properly levelled. In heavy primary tillage, twisting of the wing frames caused the outer front sweeps to penetrate about 60 mm deeper than the outer rear sweeps.

The Leon CP77-334 followed gently rolling field contours very well. The centre section was 3.4 m wide, while each wing was 3.5 m wide resulting in fairly uniform penetration across the cultivator width, in rolling fields. As with most wing cultivators, large variations in tillage depth could occur in fields with abrupt contour changes.



FIGURE 5. Excessive Wing Penetration in Heavy Primary Tillage.

Plugging: Trash clearance was very good. The Leon CP77334 was capable of clearing large amounts of trash in most conditions. In long damp straw, occasional plugging occurred between the depth control wheels and adjacent shanks.

Trash Burial and Field Surface: With 51 degree sweeps, at 75 mm tillage depth, the Leon CP77-334 left most stubble standing upright, at speeds below 6 km/h. Trash burial increased appreciably at speeds above 8 km/h. In normal conditions, sufficient trash was usually buried in first operation summerfallow to allow the use of a field cultivator for the next operation.

Trash burial with chisel points (FIGURE 6) in heavy crop residue was good. The action of the chisel points moved enough soil for adequate trash burial while leaving some standing stubble for snow retention.

Surface ridging varied from 25 to 50 mm. The optional mounted harrows were effective in smoothing these ridges (FIGURE 7).

Furrow Bottom Ridging: In normal soil conditions, furrow bottom ridging was caused by the sweep nose curvature and was less than 15 mm (FIGURE 8). Greater furrow bottom ridging occurred in hard soils, especially at the wing ends due to wing frame twisting.

Some sweeps were not held level because of faulty shank holders. This resulted in random furrow bottom ridging (FIGURE 8). This problem was corrected after the faulty shank holders were shimmed or replaced.



FIGURE 6. Typical Trash Burial with Chisel Points.

Skewing and Stability: The Leon CP77-334 was quite unstable. It skewed significantly on side slopes and in heavy draft conditions when encountering soil that varied in hardness across the machine width, resulting in weed misses. The sweep pattern (FIGURE 10) however was symmetrical and did not pose any resultant side forces on the cultivator during normal tillage. The shanks adjacent to depth control wheels were fitted with 356 mm sweeps to prevent tire interference. The minimum skew angle for weed misses between these sweeps and the adjacent 406 mm sweeps was 2.4 degrees. At several other locations shanks could not be spaced at 305 mm, due to interference of shank holders with

the frame, resulting in weed misses at similar skew angles.



FIGURE 7. Typical Field Surface when using Optional Mounted Harrows.



FIGURE 8. Typical Furrow Bottom.



FIGURE 9. Furrow Bottom Ridging caused by Faulty Shank Holders.

Weed Kill: Weed kill was good in normal conditions. Most of the cultivator had 406 mm sweeps spaced at 305 mm which gave 101 mm of sweep overlap, which was usually sufficient for good weed kill. Overlap was reduced by use of 356 mm sweeps adjacent to the depth control wheels and by imprecise shank holder placement resulting from interference with cross members at a few locations on the frame. This reduced overlap caused weed misses whenever moderate skewing occurred (FIGURE 11). Wider sweeps could be used on adjacent shanks to obtain sufficient overlap to prevent weed misses in most problem areas of the cultivator.

EASE OF OPERATION AND ADJUSTMENT

Transporting: The Leon CP77-334 was easily placed in transport position (FIGURE 12) using the hydraulic wing lift system supplied as standard equipment. Transport locks were provided

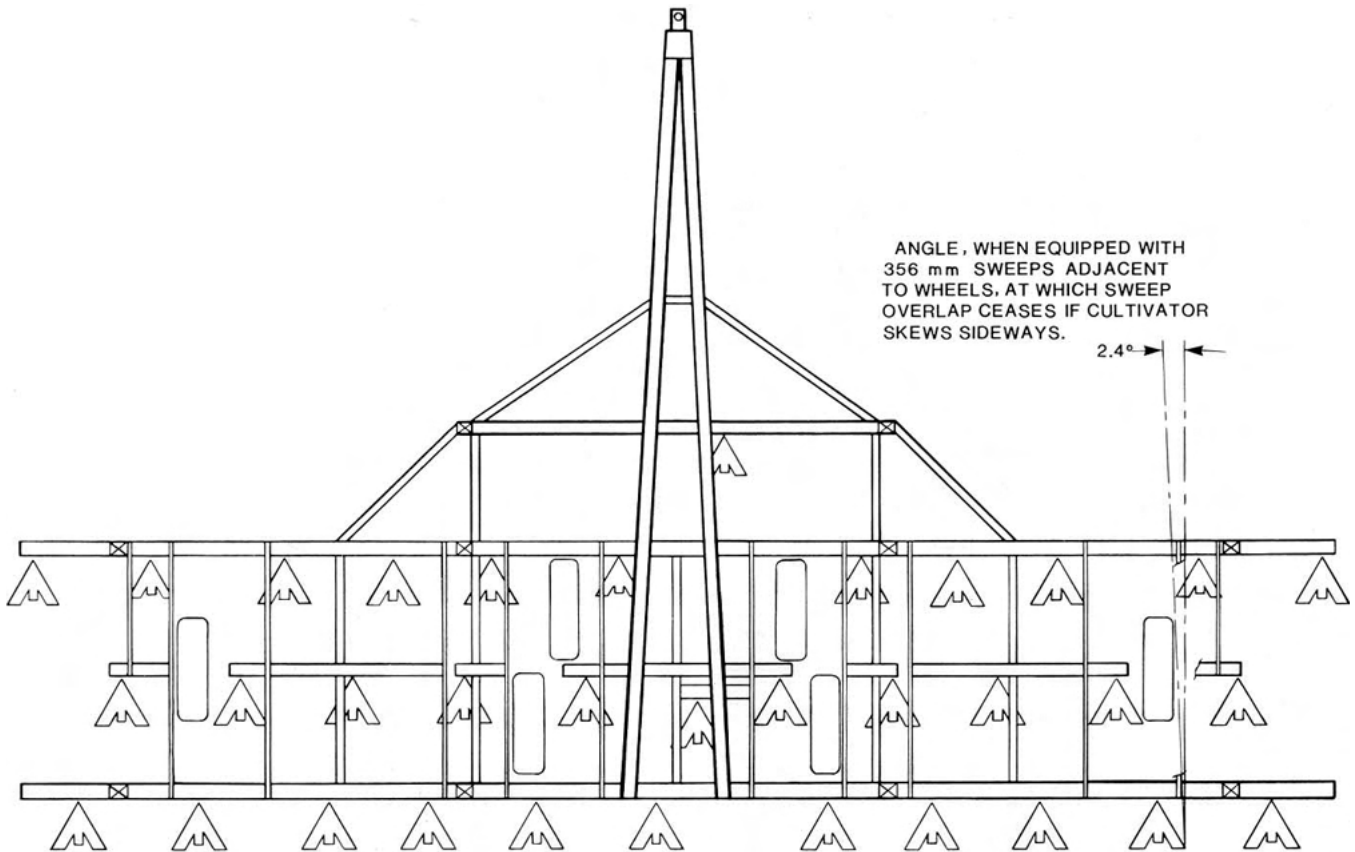

FIGURE 10. Sweep Pattern (305 mm shank spacing).

for both the wings and the centre section depth control wheels. It usually took one man less than 5 minutes to place the Leon CP77-334 in transport position. The master depth control cylinder transport lock interfered with the depth control stop (FIGURE 13). It is recommended that the safety lock be modified to eliminate this interference. The wing lock pin retainers were difficult to remove by hand. It is recommended that more functional retainers be used.



FIGURE 11. Weed Misses Caused by Skewing.

Transport width was 5.7 m while transport height was 4.4 m. Care was needed when transporting on public roads, through gates, over bridges, and beneath power or telephone lines.

The Leon CP77-334 towed well, without sway, at normal transport speeds but care had to be taken when turning corners or when transporting on rough ground because of its narrow transport wheel tread. Sweep-to-ground clearance of 200 mm and a wheel tread of 1.7 m gave good transport ground clearance.

Hitching: The hitch jack, and the rigid hitch link made one-man hitching easy. The hitch height could be adjusted 260 mm in ten increments by removing one pin. This range was adequate to allow fore-and-aft frame levelling with all tractors used during testing.

Frame Levelling: Adequate lateral levelling adjustment was provided at the depth control cylinders of both the centre and wing sections. The cylinders were adjusted at their threaded anchor ends.

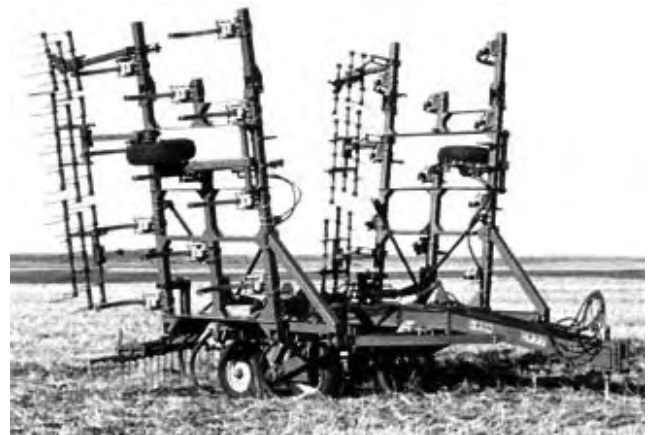

FIGURE 12. Transport Position.



FIGURE 13. Interference of Safety Lock with Depth Control Stop.

Depth of Tillage: Tillage depth was adjusted with four hydraulic, stop valve on one cylinder controlled tillage depth. Depth adjustment was easy.

Sweep Installation: It took one man about one and one-half hours to change the 34 sweeps on the Leon CP77-334. The sweep bolts were short enough to have their ends completely covered by the retaining nuts, preventing thread damage during tillage. The 200 mm sweep ground clearance was adequate for easy sweep removal.

Shank Installation: Individual shanks could be easily replaced in less than five minutes by removing one bolt.

POWER REQUIREMENTS

Draft Characteristics: FIGURE 14 shows draft requirements for heavy duty cultivators in typical primary tillage, at a speed of 8 km/h. This figure gives average requirements based on tests of 10 makes of heavy duty cultivators in 40 different field conditions.

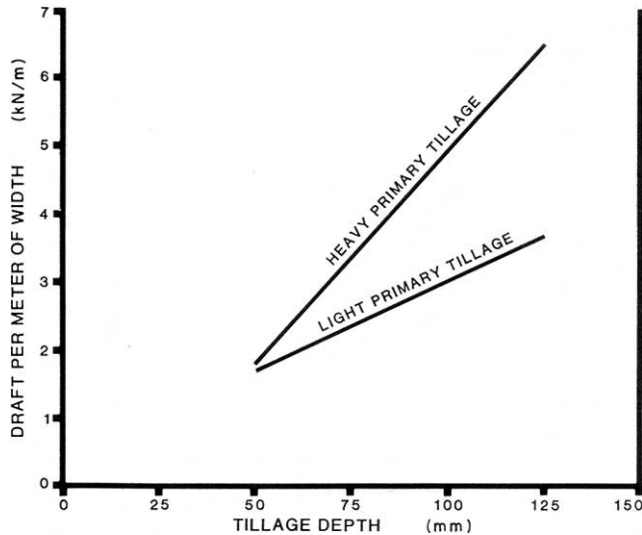

FIGURE 14. Average Draft Requirements for Heavy Duty Cultivators at 8 km/h.

Attempting to compare draft requirements of different makes of heavy duty cultivators usually is unrealistic. Draft requirements for the same cultivator, in the same field, may vary by as much as 30% in two different years, due to changes in soil conditions. Variation in soil conditions affect draft much more than variation in machine make, usually making it impossible to measure any significant draft differences between different makes of heavy duty cultivators.

In light primary tillage, average draft per metre of width, at 8 km/h, varied from 1.7 kN at 50 mm depth to 3.7 kN at 125 mm depth. For the 10.4 m wide Leon CP77-334, this corresponds to a total draft ranging from 17.7 to 38.5 kN.

In heavy primary tillage, average draft per metre of width, at 8 km/h, varied from 1.8 kN at 50 mm depth to 6.5 kN at 125 mm depth, corresponding to a total draft from 18.7 to 67.6 kN for the 10.4 m test machine.

Increasing speed by 1 km/h, increased draft by about 90 N per metre of width. For the 10.4 m wide test machine, this represents a draft increase of 0.94 kN for a 1 km/h speed increase.

Tractor Size: TABLES 2 and 3 show tractor sizes needed to operate the 10.4 m wide Leon CP77-334 in light and heavy primary tillage. Tractor sizes have been adjusted to include tractive efficiency and represent a tractor operating at 80% of maximum power on a level field. The sizes presented in the tables are the maximum power take-off rating, as determined by Nebraska tests or as presented by the tractor manufacturer. Selected tractor sizes will have ample power reserve to operate the Leon CP77-334 in the stated conditions.

Tractor size may be determined by selecting the desired tillage depth and speed from the appropriate table. For example, in light primary tillage at 75 mm depth and 10 km/h, a 125 kW tractor is needed to operate the Leon CP77-334. In heavy primary tillage, at the same depth and speed, a 153 kW tractor is needed.

TABLE 2. Tractor Size (Maximum Power Take-off Rating, kW) to operate the 10.4 m wide Leon CP77-334 in Light Primary Tillage.

DEPTH (mm)	SPEED (km/h)					
	7	8	9	10	11	12
50	54	66	78	91	106	121
75	78	93	108	125	143	161
100	101	119	138	159	180	202
125	125	146	169	192	217	242

TABLE 3. Tractor Size (Maximum Power Take-off Rating, kW) to Operate the 10.4 m wide Leon CP77-334 in Heavy Primary Tillage.

DEPTH (mm)	SPEED (km/h)					
	7	8	9	10	11	12
50	51	61	73	85	98	112
75	98	116	134	153	173	193
100	146	170	195	220	247	275
125	193	224	256	288	321	356

OPERATOR SAFETY

Extreme caution is needed in transporting most folding cultivators to avoid contacting power lines. Minimum power line heights vary in the three prairie provinces. In Saskatchewan, the energized line may be as low as 5.2 m over farm land or over secondary roads. In Alberta and Manitoba, the neutral ground wire may be as low as 4.8 m over farm land. In all three provinces, lines in farmlands may be as low as 4.6 m.

Transport height of the 10.4 m wide test machine was 4.4 m, permitting safe transport under prairie power lines. On the other hand, transport height of the 13.1 m wide model, of the Leon CP77-300 series, is 5.3 m, which is high enough for contact with many prairie power lines. The legal responsibility for safe passage under utility lines rests with the machinery operator and not with the power utility or the machinery manufacturer. All provinces have regulations governing maximum permissible equipment heights on various types of public roads. If height limits are exceeded, the operator must contact power and telephone utilities before moving.

The test machine was 5.7 m wide in transport position, necessitating caution when towing on public roads, over bridges and through gates.

Wing and depth control transport locks were provided.

No slow moving vehicle sign or mounting bracket was provided. It is recommended that a slow moving vehicle sign be supplied as standard equipment.

The Leon was stable and towed well at normal transport speeds on level ground. Because of its narrow transport wheel tread, care had to be taken during turns or when transporting on slopes or rough ground to prevent possible upset.

The tires of the optional tandem wheels on the centre frame were adequately sized to support the cultivator in transport position, even with the added weight of mounted harrows. The tires of the single centre wheels, supplied as standard equipment, would be significantly overloaded according to load limits recommended in the 1977 year book of the Tire and Rim Association Inc. It is recommended that tandem centre wheels be supplied as standard equipment to provide adequate support of the cultivator in transport position.

STANDARDIZATION

Hydraulics: During the test, considerable difficulty was encountered due to differences in hydraulic couplers on various tractors, the difficulty was in the lack of standardization both in couplers and in hose threads. More standardization is needed in this area.

Sweep Bolt Holes: The bolt hole size and spacing on cultivator sweeps and shanks, as well as stem angles, should similarly be standardized to provide some degree of interchangeability of sweeps.

OPERATOR'S MANUAL

The operator's manual supplied instructions on set-up, operation, and maintenance. It was well written and clearly illustrated.

DURABILITY RESULTS

TABLE 4 outlines the mechanical history of the Leon CP77334

during 210 hours of field operation while tilling about 1387 ha. The intent of the test was evaluation of functional performance. The following mechanical problems represent those which occurred during functional testing. An extended durability evaluation was not conducted.

TABLE 4. Mechanical History

ITEM	OPERATING HOURS	EQUIVALENT FIELD AREA (ha)
Frame		
- Several hinge pin retainer clips wore requiring replacement		During the Test
- Several press-fit grease fittings were lost		During the Test
- The frame extension stubs began deforming at	41	271
Shank And Holder		
- A shank bent when tripping over a rock and was replaced at	6	40
- Improperly sized pins allowed several bushings in the shank trips to work partially out of their holes. Proper pins were installed at	29	192
- Several faulty shank trips were noted causing shank misalignment. The faulty pieces were replaced and shims were added to all base blocks to maintain proper shank alignment	103	680
- The pivot pins on several shank trips showed excessive wear and were replaced at	103	680
- Four U-bolts broke and were replaced at	64, 207	423, 1367

DISCUSSION OF MECHANICAL PROBLEMS

FRAME

Pin Retainers: The hinge pin retainer clips wore as the pins rotated in their holes. It is recommended that one end of the hinge pins be anchored to prevent retainer clip wear action.

Grease Fittings: The press-fit grease fittings loosened during lubrication, making subsequent servicing nearly impossible. It is recommended that the grease fittings be modified to reduce field loss of fittings.

Extension Stubs: The frame extension stubs deformed during operation as shown in FIGURE 15. It is recommended that the stubs be modified to eliminate field deformation problems.

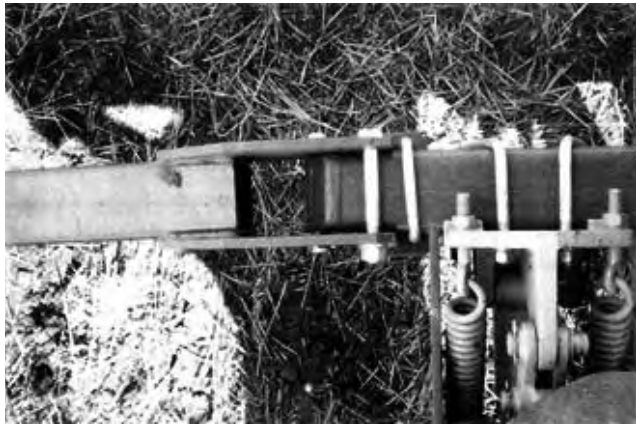

FIGURE 15. Stub Deformation.

SHANK AND HOLDER

Shanks: Only one shank bent during testing. The failure does not represent a serious problem.

Bushings: The shank trip bushings worked partially out of their holes because the pins were too long to hold them in place. The pins were replaced with shorter ones and no more problems occurred. It is recommended that proper size pins be used during trip assembly.

Shank Holders: The release shoes of the faulty trip mechanisms had improperly drilled main pivots (FIGURE 16). This resulted in misaligned shanks and excessive pivot pin wear. The faulty release shoes were replaced by the manufacturer with re-designed shoes that were properly drilled and which were bushed (FIGURE 17). The new shoes held the shanks properly, while the bushings reduced pivot pin wear. It is recommended that similar release shoes, complete with bushings be used in the trip mechanisms.

The trip-mechanism base blocks, because of oversized U-bolt fasteners, could rotate laterally causing improper shank alignment.

Shims were added to all blocks to hold them in proper position (FIGURE 18). It is recommended that all base blocks be properly shimmed during assembly to ensure proper shank alignment.

Four base block U-bolts (FIGURE 18) broke during the 210 hour test period.



FIGURE 16. Original Shank Trip Release Shoe Showing Improperly Drilled Main Pivot.



FIGURE 17. Re-designed Release Shoe Showing Properly Drilled and Bushed Main Pivot.

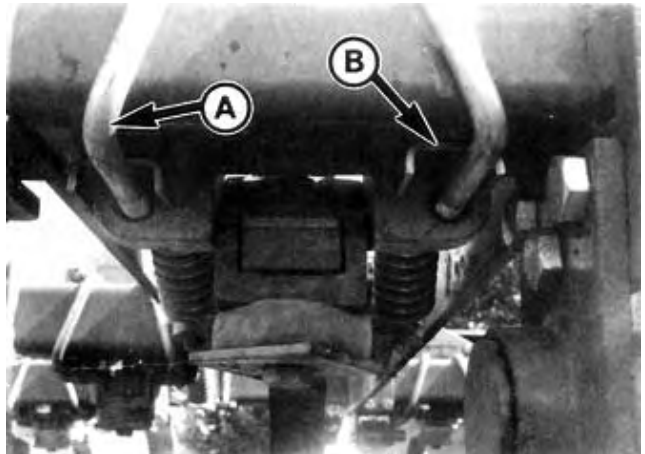

FIGURE 18. Trip Mechanism Base Block (A) U-bolt Fasteners, (B) Shims.

APPENDIX I

SPECIFICATIONS

MAKE: Leon Chisel Plow
MODEL: CP77-334 (10.4 m size)
SERIAL NUMBER: 226-803
MANUFACTURER: Leon's Manufacturing Co. Ltd.
 135 York Road East
 Yorkton, Saskatchewan
 S3N 2X3

DIMENSIONS:	FIELD POSITION	TRANSPORT POSITION
--width	10,370 mm	5710 mm
--length, w/harrows	6800 mm	6800 mm
--height	1480 mm	4360 mm
--max ground clearance	200 mm	200 mm
--wheel tread	7600 mm	1720 mm

SHANKS:		
--number	34	
--lateral spacing	305 mm	
--trash clearance (frame to sweep tip)	580 mm	
--number of shank rows		
--centre section	4	
--wings	3	
--distance between rows	910 mm	
--shank cross section	25 x 50 mm	
--shank stem angle	46°	
--sweep hole spacing	55 turn	
--sweep bolt size	7/16 x 2 in	

HITCH:		
--vertical adjustment range	260 mm	

DEPTH CONTROL:	hydraulic	
-----------------------	-----------	--

FRAME:	102 mm, 6.4 mm thick, square tubing	
---------------	-------------------------------------	--

TIRES:		
--centre section	4, 9.5L x 15, 8-ply	
--wings	2, 9.5L x 15, 8-ply	

NUMBER OF LUBRICATION POINTS:	10 grease fittings, daily service 6 wheel bearings, yearly service	
--------------------------------------	---	--

HYDRAULIC CYLINDERS:		
--depth control		
--centre section	1, 102 x 305 mm	
	1, 89 x 305 mm	
--wings	1, 102 x 254 mm	
	1, 89 x 254 mm	
--wing lift	2, 102 x 610 mm	

WEIGHTS: (Without Harrows)	FIELD POSITION	TRANSPORT POSITION
--right wheel	541 kg	
--right centre wheels	1234 kg	1860 kg
--left centre wheels	1312 kg	1823 kg
--left wheel	596 kg	
--hitch	<u>235 kg</u>	<u>235 kg</u>
TOTAL	3918 kg	3918 kg

WEIGHTS: (With Mounted Harrows)	FIELD POSITION	TRANSPORT POSITION
--right wheel	900 kg	
--right centre wheels	1247 kg	2234 kg
--left centre wheels	1330 kg	2198 kg
--left wheel	955 kg	
--hitch	<u>0 kg</u>	<u>0 kg</u>
TOTAL	4432 kg	4432 kg

OPTIONAL EQUIPMENT:
 --15 width options from 7 320 mm to 13 110 mm
 --mounted finishing harrows
 --tandem centre and wing wheels

APPENDIX II

MACHINE RATINGS

The following rating scale is used in PAMI Evaluation Reports:
 (a) excellent (d) fair
 (b) very good (e) poor
 (c) good (f) unsatisfactory

APPENDIX III

METRIC UNITS

In keeping with the Canadian Metric Conversion program, this report has been prepared in SI units. For comparative purposes, the following conversions may be used:

1 hectare (ha)	= 2.47 acres (ac)
1 kilometre/hour (km/h)	= 0.62 mile/hour (mph)
1000 millimetres (mm) = 1 metre (m)	= 39.37 inches (in)
1 kilowatt (kW)	= 1.34 horsepower (hp)
1 kilogram (kg)	= 2.20 pounds mass (lb)
1 Newton (N)	= 0.22 pounds force (lb)
1 kilonewton (kN)	= 220 pounds force (lb)
1 kilonewton/metre (kN/m)	= 70 pounds force/foot (lb/ft)



**ALBERTA
 FARM
 MACHINERY
 RESEARCH
 CENTRE**

3000 College Drive South
 Lethbridge, Alberta, Canada T1K 1L6
 Telephone: (403) 329-1212
 FAX: (403) 329-5562
<http://www.agric.gov.ab.ca/navigation/engineering/afmrc/index.html>

Prairie Agricultural Machinery Institute

Head Office: P.O. Box 1900, Humboldt, Saskatchewan, Canada S0K 2A0
 Telephone: (306) 682-2555

Test Stations:
 P.O. Box 1060
 Portage la Prairie, Manitoba, Canada R1N 3C5
 Telephone: (204) 239-5445
 Fax: (204) 239-7124

P.O. Box 1150
 Humboldt, Saskatchewan, Canada S0K 2A0
 Telephone: (306) 682-5033
 Fax: (306) 682-5080