

# Evaluation Report

141



## Melroe 505 (8.2 m) Heavy Duty Cultivator

A Co-operative Program Between



# MELROE 505 HEAVY DUTY CULTIVATOR

## MANUFACTURER AND DISTRIBUTOR:

Melroe Division, Ag Products  
Clark Equipment Company  
Bismark, North Dakota 58501  
U.S.A.

## RETAIL PRICE:

\$8287.10 (May, 1979, f.o.b. Lethbridge, 8.2 m width)

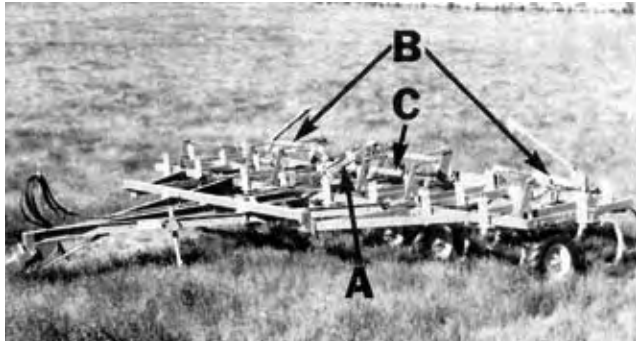

FIGURE 1. Melroe 505: (A) Master Depth Control Cylinder, (B) Wing Lift Cylinders, (C) Main Frame Rockshaft.

## SUMMARY AND CONCLUSIONS

Overall functional performance of the Melroe 505 heavy duty cultivator was good in all conditions. Its performance in heavy primary tillage was reduced by excessive sweep pitch.

The spring cushioned shank could lift only 100 mm (3.9 in) to clear stones. When equipped with sweeps having a 47 degree stem angle, the sweep pitch varied from 7 to 12 degrees over the full draft range normally encountered by heavy duty cultivators. When equipped with 50 degree sweeps the sweep pitch varied from 4 to 9 degrees. With 305 mm (12 in) shank spacings, shank cushioning spring preload was exceeded at drafts greater than 5.0 kN/m (340 lb/ft), occurring within the primary tillage draft range.

Penetration was very good in all conditions. The Melroe 505 was stable and skewed only slightly in heavy draft conditions. Skewing was never serious enough to affect weed kill. The Melroe 505 followed the contour of rolling land very well. Weed kill in all conditions was very good as long as sweeps with adequate overlap were used. Furrow bottom and surface ridging were severe when 47 degree sweeps were used but were considerably reduced when using 50 degree sweeps. The Melroe 505 was capable of clearing heavy trash and plugging seldom occurred.

The Melroe 505 could be conveniently placed in transport position in less than five minutes. The 140 mm (5.5 in) sweep-to-ground clearance in transport position was adequate. The Melroe 505 towed well at transport speeds up to 32 km/h (20 mph). Due to its large transport width, transporting on public roads had to be with extreme caution. The 8.2 m (27 ft) wide test machine had a transport height of 3.1 m (10.2 ft), permitting safe transport under power lines in the three prairie provinces. Transport heights of some of the wider models of the Melroe cultivator, are higher than minimum power line heights in all three provinces.

A hitch jack was provided for convenient hitching. Adequate adjustment was provided for both lateral and fore-and-aft levelling. Tillage depth was uniform across the width of the cultivator as long as all linkage and cable lengths were properly adjusted.

Average draft for the 8.2 m (27 ft) wide test machine, in light primary tillage, at 8 km/h (5 mph) varied from 13.9 kN (3060 lb) at 50 mm (2 in) depth to 30.3 kN (6670 lb) at 125 mm (5 in) depth. In heavy primary tillage at 8 km/h (5 mph), average draft varied from 14.8 kN (3260 lb) at 50 mm (2 in) to 53.3 kN (11,730 lb) at 125 mm (5 in) depth.

In light primary tillage, at 10 km/h (6.2 mph) and 75 mm (3 in) depth, a tractor with 98 kW (130 hp) maximum power take-off rating will have sufficient power reserve to operate the 8.2 m (27 ft) wide Melroe 505. In heavy primary tillage, at the same depth and speed a 120 kW (160 hp) tractor is needed.

The Melroe 505 was equipped with transport lock pins for safe towing. A bracket for mounting a slow moving vehicle sign was provided. The operator's manual was clear, concise, and well illustrated.

Only minor mechanical problems occurred during the 255 hours of field operation, none of which seriously affected cultivator performance.

## RECOMMENDATIONS

It is recommended that the manufacturer consider:

1. Supplying sweeps having a 50 degree stem angle rather than the recommended 47 degree stem angle.
2. Providing a slow moving vehicle sign as standard equipment.
3. Providing some means of holding the hitch link in the horizontal position to facilitate one-man hitching.
4. Working with the agricultural equipment industry to standardize hydraulic quick couplers and hydraulic hose fitting threads.
5. Working with the agricultural equipment industry to standardize shank and sweep stem angles, and sweep fastener spacings and sizes.

Chief Engineer: E. O. Nyborg

Senior Engineer: E. H. Wiens

Project Engineer: R. C. Papworth

## THE MANUFACTURER STATES THAT

With regard to recommendation number:

1. We feel, depending on conditions, either the 47° or 50° angle will do a very good job on this cultivator. The 1980 model will have a thicker shank and heavier springs for holding the shank in its correct position for deeper tillage. This should alleviate some of the problems that were experienced.
2. We provide only the mounting for the slow moving vehicle sign.
3. This hitch link must be free to move up and down in order to prevent wearing the drawbar on the tractor.
4. We are a member of the Farm and Industrial Equipment Institute (FIEI) and this has come up several times; hopefully, in the future this can be standardized.
5. This has also been and is under investigation by the agricultural committees of FIEI. We all agree this should be done, but with all the companies that manufacture these items, it is very difficult.

## GENERAL DESCRIPTION

The Melroe 505 is a trailing, flexible, three-section heavy duty cultivator suitable for medium and heavy primary tillage operations. It is available in four widths ranging from 6.7 to 9.5 m. The test machine was an 8.2 m model with a 4 m centre frame and two 2.1 m wings. It was equipped with 27 spring cushioned shanks, laterally spaced at 305 mm, arranged in three rows.

The centre frame is carried on two dual wheel sets, while each wing is supported by a single wheel. Tillage depth of the centre section is controlled by a master cylinder and rockshaft linked to each tandem wheel set. Each wing wheel is controlled with cables attached to the rockshaft. The wings fold into upright position with two hydraulic cylinders connected in parallel. A tractor with dual remote hydraulic controls is needed to operate the Melroe 505.

Detailed specifications are given in APPENDIX I while FIGURE 1 shows the location of major components.

## SCOPE OF TEST

The Melroe 505 was operated in the field conditions shown in TABLE 1, for 255 hours, while cultivating about 1352 ha. It was evaluated for quality of work, ease of operation and adjustment, power requirements, safety, and suitability of the operator's manual.

## RESULTS AND DISCUSSION QUALITY OF WORK

**Shank Characteristics:** There is a large variation in shank and sweep stem angles (FIGURE 2) on cultivators from different manufacturers. Sweeps and shanks must be matched to obtain

sufficient sweep pitch to achieve and maintain penetration. Usually manufacturers recommend sweeps with a stem angle from 0 to 5 degrees less than the shank stem angle to result in a slightly positive no-load sweep pitch. Sweep pitch increases in proportion to draft due to shank flexing and, depending on shank stiffness and cushioning spring preload, may become excessive in normal tillage, on some cultivators. A slightly positive sweep pitch results in uniform tillage depth and a smooth furrow bottom while excessive sweep pitch causes furrow bottom ridging and rapid sweep tip wear. Shanks which maintain a relatively constant sweep pitch, over the normal range of tillage forces, are desirable.

TABLE 1. Operating Conditions

| FIELD CONDITIONS    | HOURS | FIELD AREA (ha) |
|---------------------|-------|-----------------|
| Soil Type           |       |                 |
| - sand              | 78    | 413             |
| - loam              | 118   | 526             |
| - clay              | 59    | 313             |
| TOTAL               | 255   | 1352            |
| Stony Phase         |       |                 |
| - stone free        | 122   | 647             |
| - occasional stones | 92    | 488             |
| - moderately stony  | 33    | 175             |
| - very stony        | 8     | 42              |
| TOTAL               | 255   | 1352            |

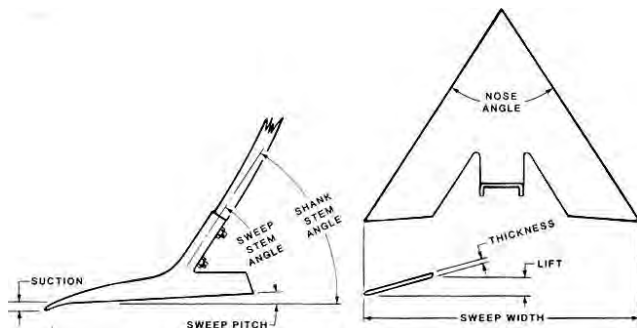

FIGURE 2. Shank and Sweep Terminology.

The Melroe 505 was equipped with spring cushioned shank holders. Cushioning spring preload was adjustable. During the test, the Melroe 505 was used with 406 mm wide Edwards sweeps with a sweep stem angle of 47 degrees, giving a no-load sweep pitch of 7 degrees and with 50 degree sweeps, giving a no-load sweep pitch of 4 degrees.

FIGURE 3 shows pitch characteristics of the Melroe 505 shank assembly. The low end of the pitch curve results from shank flexing, while the steeper upper part of the curve occurs when draft is large enough to overcome cushioning spring preload. Sweep pitch varied 5 degrees over the full range of draft normally occurring in primary tillage. When equipped with 47 degree sweeps, as recommended by the manufacturer, sweep pitch varied from 7 to 12 degrees over this draft range, while with 50 degree sweeps, sweep pitch varied from 4 to 9 degrees over this draft range. Cushioning spring preload was exceeded at drafts greater than 5.0 kN/m, occurring midway in the primary tillage draft range. This indicated the Melroe 505 was suitable for primary tillage but at higher drafts, sweep pitch could increase excessively.

FIGURE 4 shows the lifting pattern when shanks encounter stones or field obstructions. Maximum lift height was 100 mm. Although the shank cushioning assembly performed well, with no shank damage during the test, the shank lift height of only 100 mm resulted in many stones being pulled out or the frame having to lift to clear stones.

**Penetration:** Penetration was very good in all soil conditions when equipped with either the 50 degree or 47 degree sweeps. Penetration with the 47 degree sweeps, having an initial sweep pitch of 7 degrees, was not any better than with the 50 degree sweeps, having an initial pitch of 4 degrees. Therefore, to avoid excessive sweep pitch, it is recommended 50 degree sweeps be supplied as standard equipment.

Penetration was uniform across the cultivator width, provided

the wing wheel cables were properly adjusted. Tires were adequately sized to provide good flotation in most soil conditions. The wheels were positioned so that each centre section wheel supported about 19% of the cultivator weight while each wing wheel supported about 12%. In addition, each centre section wheel supported about 15% of the total tillage suction force while each wing wheel supported about 20%. For good flotation, and uniform tillage depth across the width, it is desirable to have wheels sized and positioned so that each supports equivalent weight and a similar tillage suction force. Depth differences between the front and rear rows of shanks were slight once the frame had been properly levelled. In all conditions, the frame remained relatively level with insignificant twisting of the wing frames.

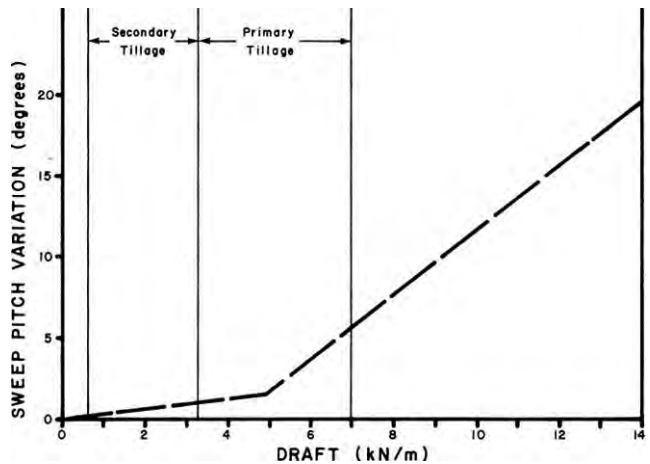

FIGURE 3. Sweep Pitch Variation over a Normal Range of Draft (305 mm shank spacing).

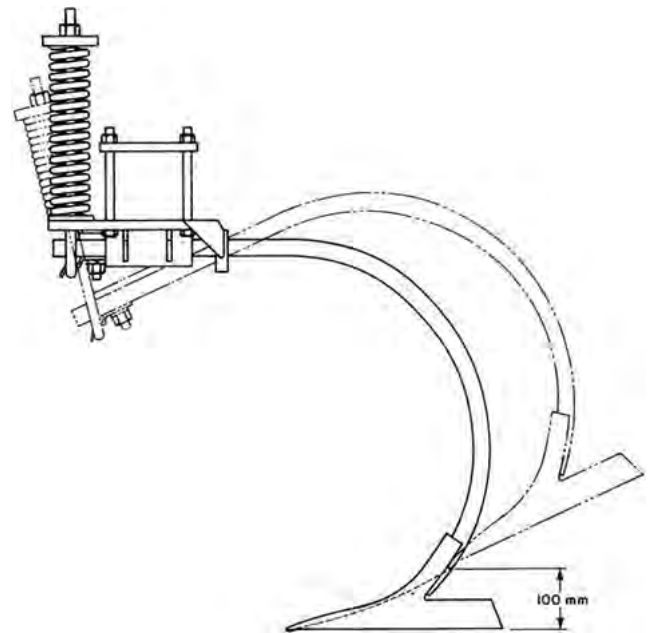

FIGURE 4. Shank Lifting Pattern.

The Melroe 505 followed gently rolling field contours very well, maintaining quite uniform depth across its width. All sections were narrow enough to result in even penetration. As with most wing cultivators, large variations in tillage depth occurred in fields with abrupt contour changes.

**Plugging:** The Melroe 505 was capable of clearing very heavy trash. Minimum plugging occurred at the shanks closest to the wheels in large dead weeds and in heavily buckwheat infested areas.

**Trash Burial and Field Surface:** With 47 degree sweeps, at 75 mm tillage depth, the Melroe left most stubble standing upright at speeds below 6 km/h. At 10 km/h, more trash was buried (FIGURE 5). More trash was also buried as tillage depth increased. Slightly less trash was buried with 50 degree sweeps.



**FIGURE 5.** Trash Burial with 47 Degree Sweeps at 75 mm Depth at 6 km/h (Left) and 10 km/h (Right).

When equipped with the recommended 47 degree sweeps, the field surface was left with severe ridges from 100 to 125 mm deep (FIGURE 6). With 50 degree sweeps, surface ridging varied from 50 to 75 mm. This further supports the recommendation to supply 50 degree sweeps as standard equipment. Ridging, with both 47 and 50 degree sweeps, was most severe in sandy soils at slower speeds.

**Furrow Bottom Ridging:** Severe furrow bottom ridging up to 50 mm resulted from the high initial pitch with 47 degree sweeps. With 50 degree sweeps, furrow bottom ridging varied from 15 to 30 mm. With both 47 and 50 degree sweeps in very hard soils, furrow bottom ridging was more severe, due to increased sweep pitch at higher drafts (FIGURE 3).

**Skewing and Stability:** The Melroe 505 was very stable and did not skew sideways in normal field conditions. Momentary skewing occurred in stony fields as the shanks sometimes would not clear large stones, causing the cultivator to skew sideways. In heavy draft conditions, at tillage depths greater than 180 mm there was slight skewing to the left. This was attributed to the shank

pattern on the centre section not being quite symmetrical. When equipped with 406 mm sweeps, the Melroe 505 had to skew more than 3.5 degrees to miss weeds (FIGURE 7). Skewing was never serious enough to cause weeds to be missed.

**Weed Kill:** Weed kill was very good when equipped with 406 mm wide sweeps. The standard sweep spacing of 305 mm resulted in 101 mm of sweep overlap. Considerable sweep wear could occur before weeds were missed. When sweeps had wore to 330 mm, larger weeds could work their way between the sweeps and be missed.

**FIGURE 6.** Surface Ridging in Loam Soil with 47 Degree Sweeps.

## EASE OF OPERATION AND ADJUSTMENT

**Transporting:** The Melroe 505 was easily placed in transport position (FIGURE 8) using the hydraulic wing lift system supplied as standard equipment. Two pins, which had to be inserted by hand, were provided to lock the wings during transport. Raising or lowering, which depended on the tractor hydraulic system, took one man less than five minutes. A mechanical lock was provided to lock up the depth control cylinder on the mainframe. Transport width was 5.6 m while transport height was 3.1 m. Extreme care was needed when transporting on public roads, through gates and over bridges. Hitch weight in transport position was 34 kg, making the Melroe stable during towing. It towed well at speeds up to 32 km/h. Sweep-to-ground clearance in transport position was 140 mm, while transport wheel tread was 3.7 m. This usually provided ample ground clearance.

**Hitching:** The Melroe 505 was equipped with a suitable hitch jack which permitted easy hitching.

The hitch link swivelled slightly downward when not hitched to a tractor (FIGURE 9). One-man hitching would have been greatly facilitated if the clevis remained horizontal.

The hitch height could be adjusted 305 mm in seven increments

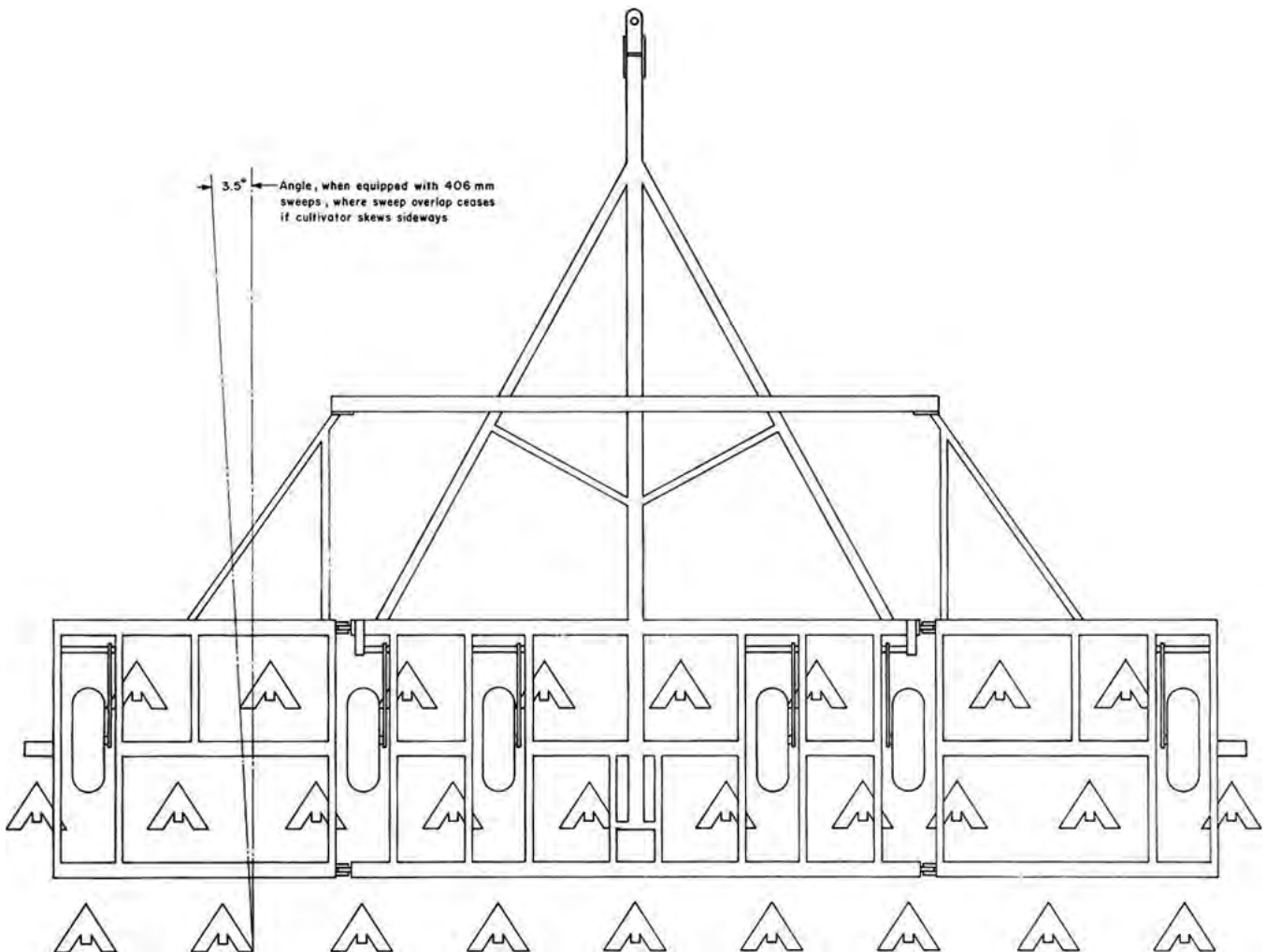

**FIGURE 7.** Sweep Pattern (305 mm spacing).

by removing one bolt. This range was adequate to allow fore-and-aft frame levelling with all tractors used during testing.

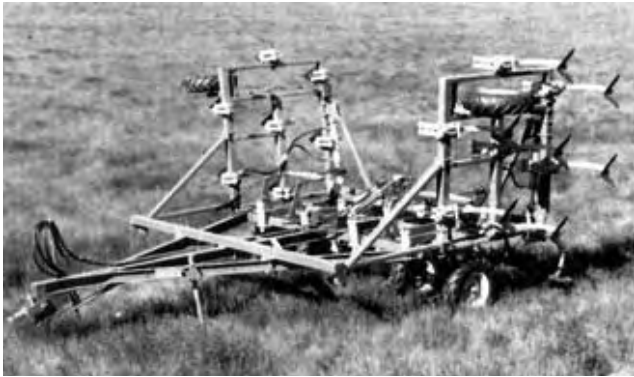

FIGURE 8. Transport Position.



FIGURE 9. Hitch Link Swivelled Downward.

**Frame Levelling:** Adequate lateral levelling adjustments were provided for both the centre and wing sections. The centre frame was levelled by adjusting a threaded link on the right dual wheels. The wing sections were levelled by means of a turnbuckle in the cables attaching the rockshaft to the wing wheels.

The cable attaching the rockshaft to the wing wheels stretched five times, necessitating frame levelling.

**Depth of Tillage:** Tillage depth is controlled by a master cylinder connected to the mainframe rockshaft (FIGURE 10). The depth of the centre section is controlled by equalizer bars connecting the rockshaft to each set of dual wheels. Wing depth is controlled by cables attached to the rockshaft.

A mechanical depth stop consisting of a block positioned in appropriate holes, between two depth control bars, provided depth adjustment (FIGURE 10). The position of the block could be conveniently adjusted without wrenches. Uniform tillage depth across the cultivator could usually be obtained with the tractor hydraulics, without using the depth control stop.

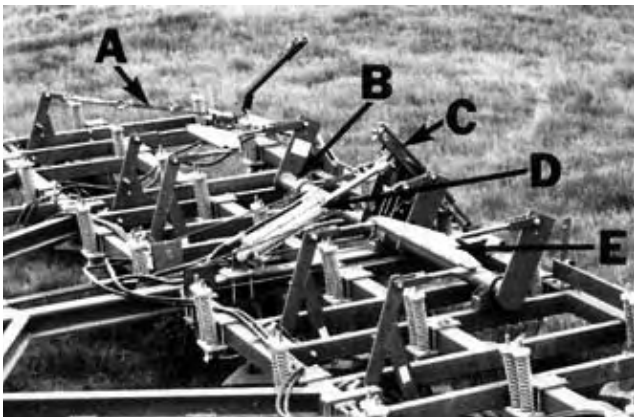

FIGURE 10. Depth Control Linkages: (A) Wing Cable, (B) Mainframe Rockshaft, (C) Depth Control Bars, (D) Master Cylinder, (E) Equalizer Bar.

**Sweep Installation:** It took one man about one hour to remove and replace the 27 sweeps on the Melroe 505. The sweep bolts were short enough to have their ends completely covered by the

nuts, preventing thread damage during tillage.

**Shank Installation:** A shank could be replaced, without removing the complete shank holder assembly from the frame, in about 15 minutes.

## POWER REQUIREMENTS

**Draft Characteristics:** FIGURE 11 shows draft requirements for heavy duty cultivators in typical primary tillage at a speed of 8 km/h. This figure gives average requirements based on tests of 10 makes of heavy duty cultivators in 40 different field conditions. Attempting to compare draft requirements of different makes of heavy duty cultivators usually is unrealistic. Draft requirements for the same cultivator, in the same field, may vary by as much as 30% in two different years, due to changes in soil conditions. Variation in soil conditions affect draft much more than variation in machine make, usually making it impossible to measure any significant draft differences between different makes of heavy duty cultivators.

In light primary tillage, average draft per metre of width at 8 km/h, varied from 1.7 kN at 50 mm depth to 3.7 kN at 125 mm depth. For the 8.2 m wide Melroe 505, this corresponds to a total draft ranging from 13.9 to 30.3 kN.

In heavy primary tillage, average draft per metre of width, at 8 km/h, varied from 1.8 kN at 50 mm depth to 6.5 kN at 125 mm depth, corresponding to a total draft from about 14.8 to 53.3 kN for the 8.2 m wide test machine.

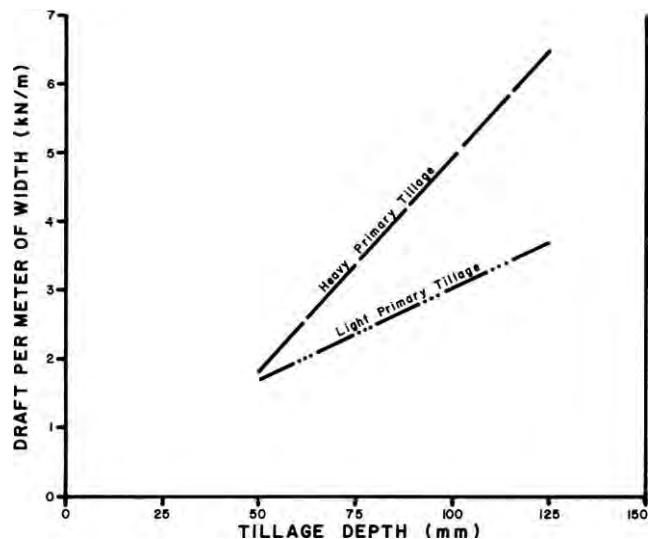

FIGURE 11. Average Draft Requirements for Heavy Duty Cultivators at 8 km/h.

Increasing speed by 1 km/h, increased draft by about 90 N per metre of width. For the 8.2 m wide test machine, this represents a draft increase of about 0.7 kN for a 1 km/h speed increase.

**Tractor Size:** TABLES 2 and 3 show tractor sizes needed to operate the 8.3 m wide Melroe 505 in light and heavy primary tillage. Tractor sizes have been adjusted to include tractive efficiency and represent a tractor operating at 80% of maximum power on a level field. The sizes presented in the tables are the maximum power take-off rating as determined by Nebraska tests or as presented by the tractor manufacturer. Selected tractor sizes will have ample power reserve to operate the Melroe 505 in the stated conditions.

Tractor size may be determined by selecting the desired tillage depth and speed from the appropriate table. For example, in light primary tillage at 75 mm depth and 10 km/h a 98 kW tractor is needed to operate the Melroe 505. In heavy primary tillage, at the same depth and speed, a 120 kW tractor is needed.

## OPERATOR SAFETY

Extreme caution is needed in transporting most folding cultivators to avoid contacting power lines. Minimum power line heights vary in the three prairie provinces. In Saskatchewan, the energized line may be as low as 5.2 m over farm land or over secondary roads. In Alberta and Manitoba, the neutral ground wire may be as low as 4.8 m over farm land. In all three provinces, lines in farmyards may be as low as 4.6 m.

Transport height of the 8.2 m wide Melroe 505 was only

3.1 m, permitting safe transport under prairie power lines. On the other hand, transport height of some of the wider models of the Melroe, is high enough for contact with many prairie power lines. The legal responsibility for safe passage under utility lines rests with the machinery operator and not with the power utility or the machinery manufacturer. All provinces have regulations governing maximum permissible equipment heights on public roads. If height limits are exceeded, the operator must contact power and telephone utilities before moving.

**TABLE 2 .** Tractor Size (Maximum Power Take-off Rating, kW) to Operate the 8.2 m Wide Melroe 505 in Light Primary Tillage.

| DEPTH (mm) | SPEED (km/h) |     |     |     |     |     |
|------------|--------------|-----|-----|-----|-----|-----|
|            | 7            | 8   | 9   | 10  | 11  | 12  |
| 50         | 43           | 52  | 62  | 72  | 83  | 95  |
| 75         | 61           | 73  | 85  | 98  | 112 | 127 |
| 100        | 80           | 94  | 109 | 125 | 142 | 159 |
| 125        | 98           | 115 | 133 | 152 | 171 | 191 |

**TABLE 3.** Tractor Size (Maximum Power Take-off Rating, kW), to Operate the 8.2 m Wide Melroe 505 in Heavy Primary Tillage.

| DEPTH (mm) | SPEED (km/h) |     |     |     |     |     |
|------------|--------------|-----|-----|-----|-----|-----|
|            | 7            | 8   | 9   | 10  | 11  | 12  |
| 50         | 40           | 48  | 57  | 67  | 77  | 88  |
| 75         | 77           | 91  | 105 | 120 | 136 | 152 |
| 100        | 115          | 134 | 153 | 175 | 195 | 216 |
| 125        | 152          | 176 | 201 | 227 | 253 | 280 |

The Melroe 505 was 5.6 m wide in transport position, necessitating caution when towing on public roads, over bridges, and through gates.

No slow moving vehicle sign was supplied, but a mounting bracket was provided. It is recommended a slow moving vehicle sign be provided as standard equipment.

Pins were provided to lock both the centre frame lift cylinder and the wings in transport position.

The Melroe 505 towed well at speeds up to 32 km/h. The four tires supporting the main frame were adequately sized for transporting the cultivator. Individual tire loads did not exceed the Tire and Rim Association's maximum rating for 7.60 x 15, 6-ply tires.

The operator's manual clearly outlined safety precautions.

## STANDARDIZATION

**Hydraulics:** During the test, considerable difficulty was encountered due to differences in hydraulic couplers on various tractors. The difficulty was in the lack of standardization both in couplers and in hose threads. More standardization is needed in this area.

**Sweep Bolt Holes:** The bolt hole size and spacing on the cultivator sweeps and shanks, as well as stem angles, should similarly be standardized to provide some degree of interchangeability of sweeps.

## OPERATOR'S MANUAL

The operator's manual was very good, containing useful information on safety, operation, maintenance, and assembly. It was clear, concise, and well illustrated.

## DURABILITY RESULTS

TABLE 4 outlines the mechanical history of the Melroe 505 during 255 hours of field operation while tilling about 1352 ha. The intent of the test was evaluation of functional performance. The following mechanical problems represent those which occurred during functional testing. An extended durability evaluation was not conducted.

## DISCUSSION OF MECHANICAL PROBLEMS

### SWEEPS AND SHANKS

**Sweep Wear:** As is common with most cultivators, rapid, non-uniform wear occurred on the sweeps which followed the cultivator and tractor wheel tracks. Complete sweep sets needed replacement twice in 255 hours. Sweep wear rate depends on the type and abrasiveness of the soil. Great variation can be expected.

**TABLE 4.** Mechanical History

| ITEM  | OPERATING HOURS        | EQUIVALENT FIELD AREA (ha) |
|---|------------------------|----------------------------|
| <b>Sweeps and Shanks</b>  |                        |                            |
| -Complete sets of worn sweeps were replaced at                              | 101, 190               | 535, 1007                  |
| <b>Hydraulics</b>   |                        |                            |
| -The depth control cylinder began to leak and was repaired at               | 59                     | 313                        |
| <b>Frame</b>  |                        |                            |
| -The depth control cables to the wing wheels stretched and were adjusted at | 16, 122, 166, 185, 236 | 85, 647, 880, 981, 1251    |
| -The centre section frame required levelling at                             | 122, 185               | 647, 981                   |
| -The right centre section tire began to show considerable lug wear at       | 25                     | 133                        |

### FRAME

**Wing Wheel Depth Control Cables:** The wing wheel depth control cables required adjustment five times during testing, due to stretching.

### TIRE WEAR

Considerable lug wear occurred to the right mainframe tire while transporting. Wear was caused by wheel misalignment and no adjustment was possible.

**APPENDIX I**

**SPECIFICATIONS**

**MAKE:** Melroe Heavy Duty Cultivator  
**MODEL:** 505 (8.2 m size)  
**SERIAL NUMBER:** 1764  
**MANUFACTURER:** Melroe Division, Ag Products  
 Clark Equipment Company  
 Bismark, North Dakota 58501

| <b>DIMENSIONS:</b>        | <b>FIELD POSITION</b> | <b>TRANSPORT POSITION</b> |
|---------------------------|-----------------------|---------------------------|
| -width                    | 8380 mm               | 6045 mm                   |
| -length                   | 6270 mm               | 6270 mm                   |
| -height                   | 1780 mm               | 3050 mm                   |
| -maximum ground clearance | 140 mm                | 140 mm                    |
| -wheel tread              | 3740 mm               | 7430 mm                   |

**SHANKS:**

|                                       |            |
|---------------------------------------|------------|
| -number                               | 27         |
| -lateral spacing                      | 305 mm     |
| -trash clearance (frame to sweep tip) | 610 mm     |
| -number of shank rows                 | 3          |
| -distance between rows                | 813 mm     |
| -shank cross section                  | 25 x 50 mm |
| -shank stem angle                     | 54°        |
| -sweep hole spacing                   | 57 mm      |
| -sweep bolt size                      | 11 mm      |

**HITCH:**

|                            |        |
|----------------------------|--------|
| -vertical adjustment range | 305 mm |
|----------------------------|--------|

**DEPTH CONTROL:**

hydraulic

**FRAME:**

102 mm square tubing

**TIRES:**

6, 7.60 x 15 in 6-ply bar lug tread

**NUMBER OF LUBRICATION POINTS:**

3 rockshaft bearings 5 hour service  
 6 pulleys - 5 hour service  
 6 wheel bearings - annual service

**HYDRAULIC CYLINDERS:**

|                                  |                 |
|----------------------------------|-----------------|
| -mainframe, depth control master | 1, 100 x 356 mm |
| -wing lift                       | 2, 89 x 457 mm  |

**WEIGHTS:**

|                            | <b>FIELD POSITION</b> | <b>TRANSPORT POSITION</b> |
|----------------------------|-----------------------|---------------------------|
| -right wing wheel          | 356 kg                |                           |
| -right centre frame wheels | 1164kg                | 1517kg                    |
| -left centre frame wheels  | 1164kg                | 1517kg                    |
| -left wing wheel           | 356 kg                |                           |
| -hitch                     | 28 kg                 | 34 kg                     |
| Total                      | 3068 kg               | 3068 kg                   |

**OPTIONAL EQUIPMENT:**

- spring cushion shanks with 711 mm clearance
- implement rib tires
- shank lowering kit (for shanks located directly behind tractor tires)
- stroke control kit for depth control cylinder

**APPENDIX II**

**MACHINE RATINGS**

The following rating scale is used in PAMI Evaluation Reports:

|               |                    |
|---------------|--------------------|
| (a) excellent | (d) fair           |
| (b) very good | (e) poor           |
| (c) good      | (f) unsatisfactory |

**APPENDIX III**

**METRIC UNITS**

In keeping with the Canadian Metric Conversion Program, this report has been prepared in SI units. For comparative purposes, the following conversions may be used:

|                                     |                                |
|-------------------------------------|--------------------------------|
| 1 hectare (ha)                      | = 2.47 acres (ac)              |
| 1 kilometre/hour (km/h)             | = 0.62 mile/hour (mph)         |
| 1000 millimetres (mm) = 1 metre (m) | = 39.37 inches (in)            |
| 1 kilowatt (kW)                     | = 1.34 horsepower (hp)         |
| 1 kilogram (kg)                     | = 2.20 pounds mass (lb)        |
| 1 newton (N)                        | = 0.22 pounds force (lb)       |
| 1 kilonewton (kN)                   | = 220 pounds force (lb)        |
| 1 kilonewton/metre (kN/m)           | = 70 pounds force/foot (lb/ft) |



3000 College Drive South  
 Lethbridge, Alberta, Canada T1K 1L6  
 Telephone: (403) 329-1212  
 FAX: (403) 329-5562  
<http://www.agric.gov.ab.ca/navigation/engineering/afmrc/index.html>

**Prairie Agricultural Machinery Institute**

Head Office: P.O. Box 1900, Humboldt, Saskatchewan, Canada S0K 2A0  
 Telephone: (306) 682-2555

Test Stations:

P.O. Box 1060  
 Portage la Prairie, Manitoba, Canada R1N 3C5  
 Telephone: (204) 239-5445  
 Fax: (204) 239-7124

P.O. Box 1150  
 Humboldt, Saskatchewan, Canada S0K 2A0  
 Telephone: (306) 682-5033  
 Fax: (306) 682-5080