

# Evaluation Report

# 488



**New Holland 849 Round Baler**

A Co-operative Program Between



# NEW HOLLAND 849 ROUND BALER

## MANUFACTURER:

New Holland  
New Holland, Pennsylvania  
17557 USA

## DISTRIBUTORS:

New Holland  
Box 1616  
Calgary, Alberta T2P 2M7

## RETAIL PRICE:

\$19,856.00 (January 1986, f.o.b. Portage la Prairie, Manitoba) with optional bale ejector, apron chain reverse drive, apron chain oiler, pickup gauge wheel, bale counter and auto wrap.

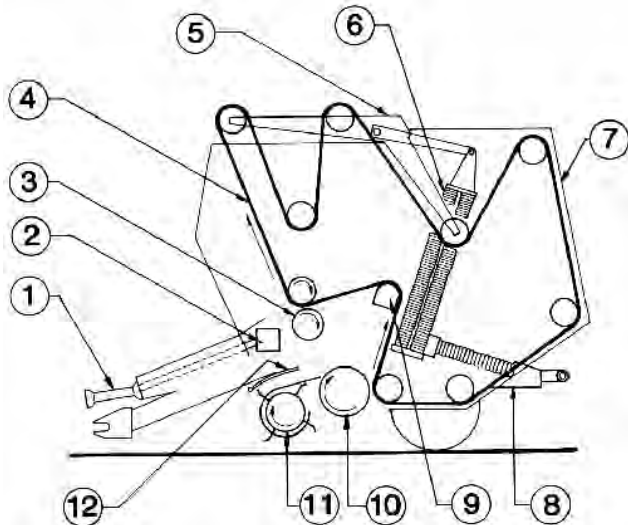

FIGURE 1. New Holland 849 Round Baler: (1) Drive Shaft, (2) Gearbox, (3) Stripper Roll, (4) Apron Chain, (5) Apron Chain Tension Pilot Arms, (6) Bale Tension Springs, (7) Tailgate, (8) Bale Ejector, (9) Core Forming-Cam Idler, (10) Floor Roll, (11) Pickup, (12) Windguard.

## SUMMARY

The functional performance of the New Holland 849 round baler was very good<sup>1</sup> in hay, high moisture green-feed (silage) and most straw crops. Baling short straw required slow power take-off speeds, and damp conditions to help form the core.

**Capacity:** The average throughput of the New Holland 849 varied from 3.5 ton/h (3.2 t/h) in alfalfa-bromegrass to 12.0 ton/h (10.9 t/h) in alfalfa. Throughput was usually limited by pickup and feeding performance rather than by bale chamber capacity.

**Bale Quality:** Bale quality was very good, with well formed and durable bales in all crops except short straw. In this case, bale quality was fair to good due to poor bale durability. Hay bales weighed from 850 to 1000 lb (385 to 454 kg) and straw bales from 570 to 650 lb (260 to 295 kg).

**Weatherability:** Resistance to bale moisture penetration and spoilage was very good after 70 days of weathering.

**Leaf Loss:** Total leaf loss varied from 1.0 to 3.3% for 16% and 11% moisture contents respectively. This was very good.

**Power Requirements:** Peak power requirements were about 22 hp (16.4 kW) in hay and straw on level fields. A 65 hp (49 kW) tractor was needed to fully utilize baler capacity on soft and hilly fields.

**Ease of Operation:** Starting and forming the bale was very easy with the New Holland 849. In short straw; reduced power take-off speed was required to start the bale.

The automatic twine wrapping device required the operator to stop, once the wrapping operation began. A bale ejector and reverse apron chain drive made backing unnecessary to clear the bale from under the gate. A bale could be wrapped and discharged in about 20 seconds.

Feeding was positive and aggressive in all crops. Overloading the pickup caused shearbolt failure or activation of the slip clutch.

The New Holland 849 was easy to maneuver and transport, Visibility to the rear was restricted.

**Ease of Adjustment:** Servicing, maintenance and routine adjustments were simple.

**Operator Safety:** The New Holland was safe to operate if personal precautions were observed.

**Operator's Manual:** The operator's manual was clearly written and useful.

**Mechanical History:** A slight bow in five of the apron bars was apparent during 191 hours of field test,

## RECOMMENDATIONS:

No recommendations were concluded during the test.

Station Manager: G. M. Ormichinski

Project Engineer: R. R. Hochstein

## THE MANUFACTURER COMMENTS:

Regarding your comments on a manual override on the bale size safeguard as discussed under "Ease of Adjustment of Bale Size and Wrap Settings", our experience shows that the twine will normally start on its own even if the pickup is not feeding material into the baler. In the unlikely event this does not happen, the PTO can be disengaged and the twine tail placed under the bale by hand and the PTO re-engaged to start the wrapping cycle. This safety feature was designed on this machine so as to not allow machine damage from overfilling. A manual override would possibly negate this safety feature.

Regarding your comments on material buildup between the pickup and floor roll, as discussed under "Ease of Adjustment of the Pickup", we have experienced this on occasion but found the number of cases to be very limited. In very extreme cases, we have modified either the roll or the pickup; but no permanent design changes will be made to the machine since it is no longer being manufactured. This concern has been addressed on our newer models.

## GENERAL DESCRIPTION

The New Holland 849 is a pull-type, power take-off driven baler with a cylindrical baling chamber and a floating drum pickup. The twine wrapping mechanism is totally automatic. Dual twine guide tubes are actuated through the baler drive system. Both bale size and number of wraps can be manually set.

Hay is fed directly into the 4.8 ft (1.45 m) wide baling chamber by the pickup. The baling chamber is an expanding chamber type with a 16.5 in (420 mm) diameter floor roll and 7.5 in (190 mm) diameter stripper roller. The bale forming device comprises of a spring loaded apron chain made up of 1.6 in (42 mm) diameter tubes spaced at 3.3 in (84 mm) and riveted to roller chains at each side of the bale chamber.

The apron chain automatically stops when unloading the bale, then reverses when the door is fully open to eject the bale. A bale ejector and the reversing apron chain drive rolls the bale out away from under the door to permit immediate closing.

Detailed Specifications are given in APPENDIX I, while FIGURE 1 shows the location of major components.

The machine supplied to PAMI was equipped with the following options: bale counter; right-hand pickup gauge wheel; apron chain oiler; bale ejector bundle; pickup limit chains; reverse apron chain drive.

## SCOPE OF TEST

The New Holland 849 baler was operated in a variety of crops (TABLE 1) for 191 hours, while producing 2812 bales. It was evaluated for rate of work, quality of work, power requirements, ease of operation, ease of adjustment, operator safety and suitability of the operator's manual.

<sup>1</sup>See rating table provided in Appendix II

**TABLE 1.** Operating Conditions

Crop	Hours	Number of Bales	Field Area	
			ac	ha
Alfalfa	58	1250	300	122
Alfalfa, Bromegrass	58	450	230	93
Alfalfa, Timothy	34	360	135	55
Grass	8	94	35	14
HighMoisture Green Feed	10	198	40	16
Flax Straw	7	130	50	20
Barley Straw	13	260	100	40
Wheat Straw	3	70	15	6
Total	191	2812	905	366

**RESULTS AND DISCUSSION**

**RATE OF WORK**

Average throughput depended on windrow size, uniformity of crop conditions, field surface, available tractor speeds and operator skill. Average throughput for the New Holland 849 (TABLE 2) varied from 3.5 ton/h (3.2 t/h) in alfalfa-bromegrass to 12.0 ton/h (10.9 t/h) in alfalfa. The values in Table 2 are all based on average workrates for daily field operation. Peak workrates during any one day were generally 10 to 20% higher.

**TABLE 2.** Typical Average Throughputs

Crop	Crop Yield		Daily Average Throughput	
	ton/ac	t/ha	ton/h	t/h
Alfalfa: Field A	2.0	4.5	8.2	7.5
Field B	2.0	4.5	12.0	10.9
Alfalfa, Bromegrass	0.9	2.0	3.5	3.2
Alfalfa, Timothy	1.6	3.5	6.2	5.6
Green Feed Oats (57% MC)	3.7	8.4	15.0	13.6
Flax Straw	0.9	2.0	6.0	5.4
Barley Straw	0.8	1.8	6.7	6.1

In most crops, the feedrate was primarily limited by windrow size and pickup/feeding performance. In lighter crops, the ground speed was normally limited to about 9 mph (14 km/h) due to rough ground and pickup performance

Three options included on the New Holland 849 allowed a relatively short bale formation cycle. These were the fully automatic, dual tube, twine wrap, the bale ejector bundle, and the apron chain reversing drive.

**QUALITY OF WORK**

**Bale Quality:** The New Holland 849 produced firm, durable bales with flat ends and uniform diameter in all hay crops (FIGURE 2). Short straw generally resulted in a less durable bale for handling, however setting the twine wrap for maximum number of wraps (23) made a satisfactory bale. The overall bale quality depended greatly on the operator experience. Failure of the operator to evenly feed both sides of the baler in light windrows resulted in barrel or cone-shaped bales.



**FIGURE 2.** Typical Hay Bale.

A typical hay or straw bale averaged 4.8 ft (1.45 m) in width and 5 ft (1.52 m) in diameter. Bales usually settled to about 93% of their original height after 100 days. Average hay bales weighed from 850 to 1000 lb (385 to 454 kg) with average densities ranging from 9.1 to 10.7 lb/ft<sup>3</sup> (146 to 172 kg/m<sup>3</sup>). Average straw bales weighed from 570 to 650 lb (260 to 295 kg) with average densities ranging

from 6.1 to 7.0 lb/ft<sup>3</sup> (98 to 111 kg/m<sup>3</sup>). Green oats and barley baled at 57% and 50% moisture content respectively produced a high density bale weighing from 1100 to 1200 lb (500 to 545 kg). The NH 849 was capable of producing a heavier bale in this case, however, the bale size was set to produce a 4.1 ft (1.25 m) diameter bale in order not to exceed the machine's maximum recommended bale weight of 1200 lb (545 kg).

The density of the high moisture greenfeed ranged from 17.3 to 18.9 lb/ft<sup>3</sup> (281 to 306 kg/m<sup>3</sup>).

**Bale Weathering:** During a period of 70 days, over which a total rainfall was measured at 4.4 in (11 cm). Moisture had penetrated to a maximum of 2 in (50 mm) on the windward side in the area where another bale had been touching. Spoilage occurred to a depth of 1.0 in (25 mm) in the ground contact area.

**Leaf Loss:** The New Holland was tested for leaf loss in an average crop of alfalfa, which had been cut with a 10 ft (3 m) mower conditioner and in which two swaths were raked together to form a single windrow. Average crop yield was about 2.4 ton/ac (2.2 t/ha). Total leaf loss ranged from 1.0% at 16% M.C. to 3.3% at 11%, M.C. which was considered very good.

The importance of baling at a high moisture content on losses can be noted in FIGURE 3. This figure represents an accumulation of previous data for several round balers showing the total measured leaf loss over a range of moisture contents, in fields of mixed alfalfa-crested wheatgrass and bromegrass. Although the New Holland 849 was tested in a different crop, its performance was above that presented in the figure.

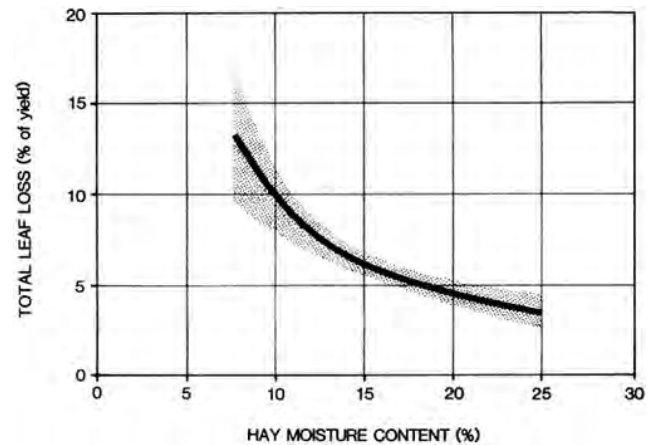

**FIGURE 3.** Leaf Loss in Mixed Alfalfa, Crested Wheatgrass and Bromegrass.

FIGURE 3 does not include relative effects of baling unconditioned or light windrows. Heavy, conditioned windrows are important to minimizing losses. Lower power take-off speed is also effective in reducing the number of times the bale turned in the chamber, and consequently reducing leaf loss.

The twine wrapping mechanism used double feeding tubes, one at each side of the bale. This, as well as the automatic engagement, minimized the time required to tie a bale. This relatively short tying time contributed significantly to the low losses measured for the NH 849.

**POWER CONSUMPTION**

**Power Requirements:** FIGURE 4 shows the power takeoff and drawbar power requirements for the New Holland 849. The power input is plotted against bale weight to show the power requirements while a bale is formed. Power take-off input varied from 4 hp (3 kW) at no load to a maximum of 18 hp (13.4 kW) in alfalfa and barley straw. Drawbar requirements at 6.6 mph (10.6 km/h) on flat firm fields were about 3.0 hp (2.2 kW) when the bale reached maximum size. Although maximum horsepower requirements did not exceed 22 hp (16.4 kW), additional power was needed to suit field conditions. In soft, hilly fields, a 65 hp (49 kW) tractor would be needed to fully utilize baler capacity.

**Specific Capacity:** Specific capacity is a measure of how efficiently a machine performs a task. A large specific capacity indicates efficient energy use. The specific capacity of the New Holland 849 was about 0.91 ton/hp-h (1.11 t/kW-h) in alfalfa at a work rate of 13 ton/h (11.8 t/h). This specific capacity was greatly

influenced by the workrate. This compares to an average specific capacity of 0.6 to 1.2 ton/hp-h (0.7 to 1.4 t/kW-h) for small square balers in alfalfa.

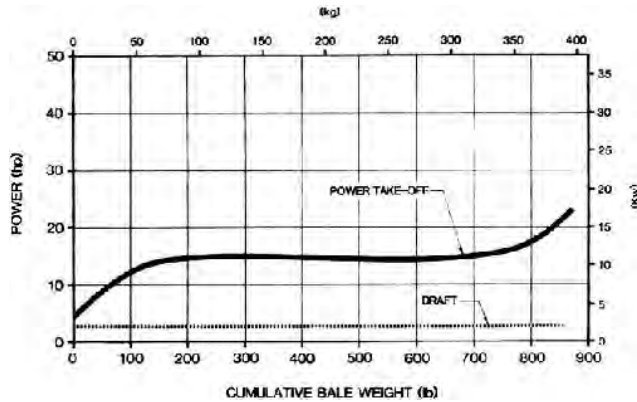

FIGURE 4. Power Consumption During Bale Formation in Alfalfa-Bromegrass.

### EASE OF OPERATION

**Forming a Bale:** It was easy to form a neat, durable bale in most crops. Feeding hay across the width of the bale chamber by weaving was essential to form a uniform core. Alternate side to side feeding, to a count of at least ten at each side, was required during the later stages of bale formation to produce bales of uniform diameter. FIGURE 5 shows stages of the bale formation in the New Holland 849.



FIGURE 5. Stages of Bale Formation: (Left) Starting Bale, (Centre) Partially Completed Bale, (Right) Completed Bale.

In very dry and short straw, especially straw from a rotary combine, the baler occasionally had difficulty forming the core. It was found that decreasing the power take-off speed and baling during late evening or morning when the straw was slightly damp, improved the performance considerably.

**Wrapping the Twine:** The twine wrapping on the New Holland 849 was totally automatic. A bale size indicator on the right upper front of the baler cued the operator to watch for a stop warning just below. At this prescribed bale size setting, dual twine tubes dropped to the centre of the pickup.

The tubes, which were controlled by a cam and linkage from the main drive, then moved along the width of the bale according to the prescribed number of wraps preset by the operator. The cam held the twine tubes within 6 in (150 mm) of the ends of the bale for about 3 to 4 wraps. The cutting mechanism used knives at each end to cut the twine. The twine cutter performed very well.

The number of wraps was adjustable for settings of 10, 14, 18 and 23 wraps, simply by relocating the twine wrapping mechanism drive belt to one of two drive or driven pulleys to attain the desired setting. This adjustment, including the tension setting for the belt, was very convenient. The maximum wrap setting of 23 was generally used for baling short straw or alfalfa bales that required a lot of handling. The 10 and 14 wrap settings were generally satisfactory for a good durable bale. For shorter hay, the 18 wrap setting was used.

Twine requirements varied with the type of crop conditions, type of twine and the desired bale durability. Twine consumption for the New Holland 849 was 315 ft/ton (105 m/t) at the 10 wrap setting and 722 ft/ton (242 m/t) at the 23 wrap setting. The fully automatic twine tubes tended to conserve twine as the tubes moved uniformly across the bale width, thus utilizing the twine to its greatest effectiveness. No operator skill was really required for this operation.

Twine wrapping performance was occasionally affected by build-up of loose material in and around the mechanism. Periodic clearing away of the build-up was required. Twine tension adjustment was required only during initial set-up.

Upon delivery of the machine, paint and a lack of lubrication

in key areas of the wrapping mechanism caused minor problems in this mechanism. These diminished once the baler was initially broken in. The twine tubes were protected with a break-away latch. The breakaway force was easily adjusted.

**Discharging a Bale:** Once the twine was cut, the bale was ready for ejecting by simply opening the gate with the remote hydraulics.

A bale ejector at the rear of the baler and reverse-apron chain drive facilitated rolling of the bale, as it ejected, out away from under the gate. This required the power take-off to remain running. The pickup and apron chain drive both automatically disengaged upon opening of the gate. The bale could be wrapped and discharged in 20 to 30 seconds. There was no requirement to back up prior to discharging the bale.

**Transporting:** The New Holland 849 was easy to manoeuvre and transport. Ground clearance was adequate and there was ample hitch clearance for turning sharp corners. Care was necessary when backing up or transporting on roadways due to obstructed visibility to the rear. The baler could be easily towed behind a tractor or a suitably sized truck. Dismounting was required to lift the pickup, however, the lever was convenient to operate.

**Hitching:** The New Holland 849 was easy to hitch to a tractor. The hitch height was adjustable by relocating the clevis up or down on the hitch. The hitchjack was convenient for raising and lowering the hitch tongue. The hitch jack could be pivoted into its stored position as soon as the base was clear of the ground. Full retraction of the jack was not required.

**Feeding:** Feeding was positive and aggressive in all crops with only infrequent plugging. Overloading of the windrow pickup and improper bale size setting caused the pickup shearbolt to break. The latter was a fail safe device to protect the apron chain bars from excessive stress. The operator was required to reset the safety lever when replacing the shear bolt.

A stripper roll at the top of the feeding area and good clearance between the hitch and pickup were factors which contributed to trouble free loading.

**Twine Threading:** Twine threading was convenient. Twine could be threaded without the use of wire or additional aids.

The twine cutter performed well, leaving a good length for starting the twine feed on the next bale. The knives held the twine in place during bale formation.

### EASE OF ADJUSTMENT

**Apron Chains:** Apron chain tension was provided by a set of adjustable springs on each side of the baler. Chain tension during bale core formation was maintained with a core cam idler. No adjustment to the apron tension springs was needed during the test, however, the chain tension on the core-forming cams required adjustment three times during the 191 hour test duration. The operator was required to stand up on the implement tire to make this adjustment, otherwise it was convenient.

**Pickup:** Pickup floatation was provided by pickup gauge wheels, which were assisted by an adjustable floatation spring. The gauge wheels were adjusted to give about 1 in (25 mm) clearance between the ground and the pickup teeth while the floatation spring was adjusted to carry as much weight as possible without excessive pickup bounce. The maximum pickup drop was also adjusted by a limit chain for use in rough field conditions where gauge wheels may cause excessive pickup bounce. Once proper settings were determined, no further adjustments were required during the test.

When baling high moisture greenfeed, the floor roll carried material around underneath to the front of the roll where it built up at the back of the pickup drum. The rubbing of the floor roll against this buildup tended to raise the pickup drum off the ground. It was necessary to detach the pickup drum to clear the build up. It took about two man hours to perform this operation. A floor roll scraper attached beneath the floor roll would be useful to clear this buildup during operation in high moisture crops such as this. Dry crops (20% M.C.) did not present any problem here.

**Bale Size and Wrap Settings:** The safety equipment and optional automatic tying device used additional moving parts and linkages. A trained dealer representative was required to assist in initial set-up and adjustment.

The bale size required adjusting at the start of the test. The bale size was initially set beyond the setting on the apron chain

safeguards. This caused the pickup shearbolt to break. When this occurred, it was impossible to tie the bale, since the material feed could not be used to start the wrap. A manual override on the bale size safeguard, in this instance, would greatly facilitate tying the bale, and thus dissuade the operator from attempting to manually feed the twine.

The number of wraps around the bale was convenient to set as was the belt tension. The step pulleys required only shifting the belt to an alternate pulley combination out of four that were provided. A decal on the inside of the door gave the necessary information for this procedure.

**Servicing:** The New Holland 849 used an automatic oil dispensing system for lubricating the apron chain. Oil was applied to the chains upon each opening of the gate. This system used about one gallon (4.5 L) per 100 bales. There were three other chains which required oiling every 8 to 10 hours. There was a total of 22 grease fittings and one gear box. The operator manual also recommended lubrication of most grease fittings every 8 to 10 hours and checking gear box oil and repacking the wheel bearings every season. Complete daily servicing took about 15 minutes.

### OPERATOR SAFETY

The operator is cautioned that a round baler is potentially very dangerous. The operator must disengage the power take-off and stop the tractor engine to clear blockages or to make adjustments. Many serious and fatal accidents have occurred with round balers. Most of these are caused by operators dismounting from the tractor while leaving the baler running.

The New Holland 849 was safe to operate and service as long as common sense was used and the manufacturer's safety recommendations were followed. Rotating parts were well shielded. The pickup and feeding area were well shielded to discourage operators from attempting to clear blockages with the baler in operation. The safety shields were hinged so they could not be completely removed.

The New Holland 849 had rear gate cylinder locks to permit safe servicing with the rear gate open. A slow moving vehicle sign was permanently fastened at the rear of the baler.

### OPERATOR'S MANUAL

The operator's manual was well written and contained much useful information on operation, servicing, adjustments and safety procedures.

### MECHANICAL HISTORY

The New Holland 849 was operated for 191 hours while baling 2812 bales. The intent of the test was an evaluation of functional performance and an extended durability evaluation was not conducted.

There were five apron bars that were slightly bent, about 0.4 in (10 mm) over the length of the bar. This was not considered serious and replacement of the bars was not required for continued operation.

### APPENDIX I SPECIFICATIONS

<b>MAKE:</b>	Sperry New Holland
<b>MODEL:</b>	849
<b>SERIAL NUMBER:</b>	696002
<b>MANUFACTURER:</b>	Sperry New Holland New Holland, PA
<b>DIMENSIONS:</b>	
-- width	7.5 ft (2.3 m)
-- height	8.4 ft (2.6 m)
-- length	13.5 ft (4.1 m)
-- ground clearance	12 in (305 mm)
<b>TIRES:</b>	
-- undercarriage	two, 31 x 13.50-15
-- pickup	two, 4.00 x 8
<b>WEIGHT:</b>	
-- left wheel	1764 lb (800 kg)
-- right wheel	1777 lb (806 kg)
-- hitch point	<u>1045 lb (474 kg)</u>
Total:	4586 lb (2080 kg)
<b>BALE CHAMBER:</b>	
-- width	4.8 ft (1.45 m)
-- maximum diameter	5.0 ft (1.50 m)
-- bale density control	4 tension springs on each side
-- bale peripheral speed (at 540 rpm)	4.4 mph (7.1 km/h)
<b>ROLLERS:</b>	
-- type	neoprene rubber surface
-- floor roll	
-length	4.8 ft (1.45 m)
-diameter	16.5 in (410 mm)
-speed	90 rpm
-peripheral speed	4.4 mph (7.1 km/h)
-- stripper roll	
-length	57 in (1450 mm)
-diameter	7.5 in (190 mm)
-speed	200 rpm
-peripheral speed	4.4 mph (7.1 km/h)
<b>APRON CHAIN:</b>	
-- type	replaceable steel tubes bolted to roller chains at ends
<b>DRIVES:</b>	
-- number of belt drives	three
-- number of chain drives	three
-- number of gear drives	one
-- number of universal joints	two
<b>SAFETY DEVICES:</b>	
-- main drive	shearbolt
-- pickup drive	shearbolt and slip clutch
-- rear gate	cylinder locks
-- hinged	safety shields
-- bale chamber	overload, pickup drive shear bolt breaks
-- tailgate	latch indicator
<b>SERVICING:</b>	
-- grease fittings	one, every 4 hours ten every 8 hours nine every 50 hours two yearly
-- chains	three, oil every 8 hours
-- pivot points	several, every 8 hours
<b>TRACTOR HOOK-UP:</b>	
-- connections	double action hydraulic hose
-- hitch height	13 to 17 in (330 to 430 mm)

### APPENDIX II MACHINE RATINGS

The following rating scale is used in PAMI Evaluation Reports:

Excellent	Fair
Very Good	Poor
Good	Unsatisfactory

# SUMMARY CHART

## SPERRY NEW HOLLAND 849 ROUND BALER

<b>RETAIL PRICE</b>	\$19,856.00 (January 1986, f.o.b. Portage la Prairie, MB)
<b>CAPACITY</b>	3.5 to 12.0 ton/h (3.2 to 10.9 t/h)
<b>QUALITY OF WORK:</b>	
Bale Quality	<b>Very Good</b> , dense core
Weatherability	<b>Very Good</b> , about 1 in (25 mm) spoilage Leaf Loss 1.0 to 3.3% in alfalfa hay
<b>POWER REQUIREMENTS:</b>	
Tractor size	65 hp (49 kW) tractor has sufficient reserve for most field conditions
Specific Capacity	0.91 ton/hp-h (1.11 t/kW-h)
<b>EASE OF OPERATION:</b>	
Forming a bale	<b>Very Good</b> , side to side feeding required
Wrapping the twine	<b>Excellent</b> , no experience required
Discharging the bale	<b>Excellent</b> , 20 to 30 seconds
Transporting	<b>Very Good</b> , easy to manoeuvre
Hitching	<b>Very Good</b> , jack was convenient
Feeding	<b>Very Good</b> , aggressive in all crops
<b>EASE OF ADJUSTMENT:</b>	
Apron chains	<b>Very Good</b>
Pickup	<b>Good</b> , adjusted only once
Bale Size & Wrap Settings	<b>Very Good</b> , for an experienced operator
Servicing	<b>Good</b> , about 15 min. for daily service
<b>OPERATOR SAFETY</b>	Well shielded and accessible
<b>OPERATOR'S MANUAL</b>	<b>Very Good</b> , well written
<b>MECHANICAL HISTORY</b>	Five bars on apron chain were slightly bowed.



3000 College Drive South  
Lethbridge, Alberta, Canada T1K 1L6  
Telephone: (403) 329-1212  
FAX: (403) 329-5562  
<http://www.agric.gov.ab.ca/navigation/engineering/afmrc/index.html>

### Prairie Agricultural Machinery Institute

Head Office: P.O. Box 1900, Humboldt, Saskatchewan, Canada S0K 2A0  
Telephone: (306) 682-2555

Test Stations:  
P.O. Box 1060  
Portage la Prairie, Manitoba, Canada R1N 3C5  
Telephone: (204) 239-5445  
Fax: (204) 239-7124

P.O. Box 1150  
Humboldt, Saskatchewan, Canada S0K 2A0  
Telephone: (306) 682-5033  
Fax: (306) 682-5080