

# Evaluation Report

72



## Vac-U-Fil Fuel Transfer Pump

A Co-operative Program Between



## VAC-U-FIL FUEL TRANSFER PUMP

### MANUFACTURER AND DISTRIBUTOR:

Midway Industries  
Box 17  
Florence, South Dakota 57235  
U.S.A.

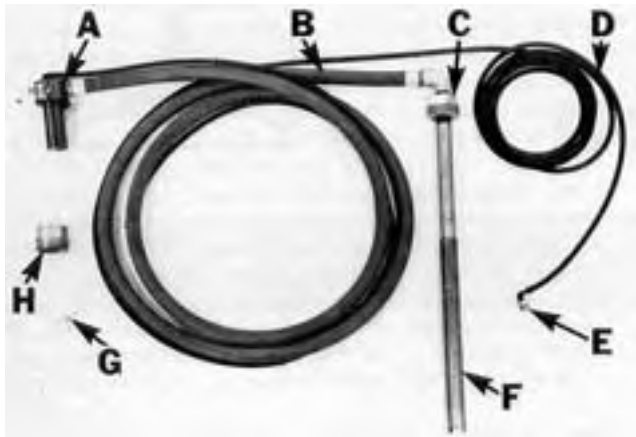

FIGURE 1. Vac-U-Fil Fuel Transfer Pump: (A) Pump Body, (B) Fuel Transfer Hose, (C) Bung Adaptor, (D) Vacuum Hose, (E) Manifold Adaptor, (F) Telescoping Suction Pipe, (G) 3 Way Barbed Tee, (H) Storage Adaptor.

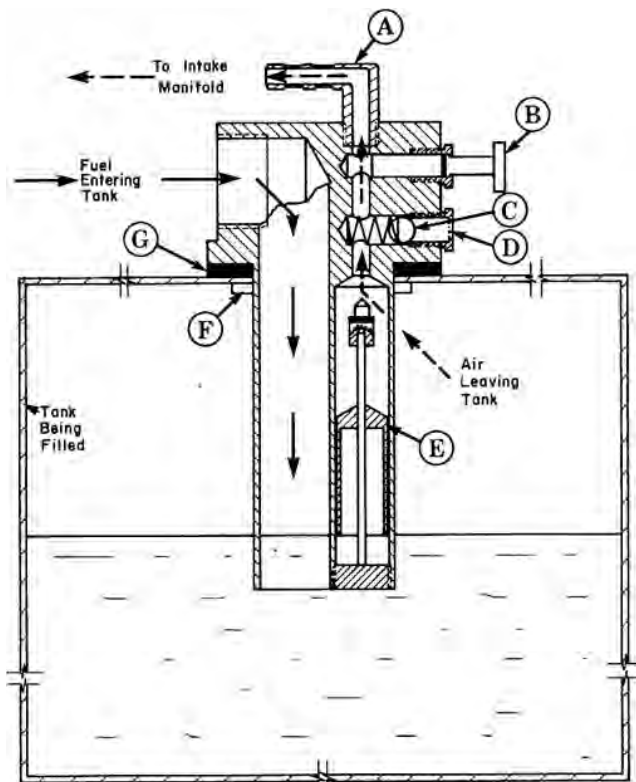

FIGURE 2. Schematic View of Vac-U-Fil Fuel Transfer Pump: (A) 90° Elbow, (B) Control Valve, (C) Relief Valve, (D) Screen, (E) Float Valve, (F) Locking Pins, (G) Gasket

### SUMMARY AND CONCLUSIONS

Maximum flowrate for the Vac-U-Fil fuel transfer pump, operating from an engine intake manifold vacuum of 64 kPa (9.3 psi), when pumping diesel fuel at zero suction head, was 38 L/min (8.4 gal/min). Increasing the suction head to 2.7 m (9 ft) resulted in a 47% reduction in flowrate. Maximum measured flowrate was 27% greater than the manufacturer's stated capacity. Maximum flowrate occurred after normal operating vacuum was reached in the tank being filled. The time required for fuel to start flowing and reach the maximum flowrate varied with tank size and suction head. It took about 8 minutes, after the pump was turned on, to fill a 225 L (50 gal) tractor fuel tank with filler opening located

0.9 m (3 ft) higher than the supply tank fuel level. At maximum flowrate, 6.9 minutes were required to fill the same tank.

The Vac-U-Fil can be operated from any engine intake manifold. Flowrate changed very little over the normal range of intake manifold vacuums created by an idling farm truck.

The Vac-U-Fil was very portable and, when not in use, stored on the fuel supply tank. The pump shut-off automatically when the fuel tank was full.

A continuously running engine to provide intake manifold vacuum for pump operation is a potential fire hazard. The Vac-U-Fil was safer than some fuel pumps since all vapours, from the fuel tank being filled, were drawn directly into the truck engine intake manifold. The fasteners, attaching the vacuum hose to the fuel transfer hose, were sharp and could cut the hands when the handling the pump.

Operating instructions and a parts list were supplied with the pump.

A few mechanical problems occurred during the test: The control valve knob broke off and the storage adaptor neck became burred, damaging the pump body gasket, all as a result of normal handling practice.

### RECOMMENDATIONS

It is recommended that the manufacturer consider:

1. Supplying a 65 mm (nominal 2.5 inch NPT) suction pipe bung adaptor as standard equipment.
2. Modifications to reduce the possibility of control valve damage during handling.
3. Supplying a more durable pump storage adaptor.
4. Modifying the vacuum hose fasteners on the fuel transfer hose to eliminate possible hand cuts when handling the pump.

Chief Engineer: E. O. Nyborg

Senior Engineer: E. H. Wiens

Project Technologist: L. B. Storzynsky

### THE MANUFACTURER STATES THAT

With regard to recommendation number:

#### PAMI COMMENTS

In spite of repeated attempts to obtain replies from the manufacturer, none were received. Also, no current Canadian retail price was available.

### GENERAL DESCRIPTION

The Vac-U-Fil is a vacuum operated fuel transfer pump. It has no moving parts. Fuel is directly transferred by intake manifold vacuum created by a gasoline truck engine. The pump consists of a telescoping suction pipe, a vacuum hose, a fuel transfer hose and a pump body (FIGURE 1). The pump body, which serves as the outlet nozzle, is screwed into the tractor fuel tank filler opening. Truck manifold vacuum draws air from the tractor fuel tank (FIGURE 2) through the vacuum hose causing fuel to flow from the supply tank, through the fuel transfer hose. The pump body can be equipped with various adaptors to fit most common filler neck openings.

Detailed specifications are given in APPENDIX I.

### SCOPE OF TEST

The Vac-U-Fil was evaluated for ease of operation, vacuum requirements and safety. Pump performance characteristics for various suction heads, engine manifold vacuum levels and tractor fuel tank sizes, were determined with diesel fuel.

### RESULTS AND DISCUSSION

#### PUMP PERFORMANCE

**Flowrates:** Pump performance characteristics with diesel fuel over a typical range of suction heads are given in FIGURE 3.

Suction head is the distance the pump body is held above supply tank fuel level. FIGURE 3 shows maximum flowrates at a typical truck engine intake manifold vacuum of 64 kPa (9.3 psi). The Vac-U-Fil must evacuate the fuel tank being filled before steady flow occurs. FIGURE 3 shows flowrates after full operating vacuum was reached.

Maximum flowrate of 38 L/min (8.4 gal/min) was obtained at zero, suction head. Increased suction head reduced the flowrate significantly. For example, increasing the suction head to 2.7 m (9 ft) resulted in a flowrate of 20 L/min (4.4 gal/min), representing a 47% decrease.

In filling a typical farm tractor, with filler opening about 1 m (3.3 ft) above the supply tank fuel level, a maximum flowrate of 33 L/min (7.3 gal/min) occurred. The maximum flowrate of 38 L/min (8.4 gal/min) was 27% greater than the manufacturer's stated flowrate of 30 L/min (6.7 gal/min).

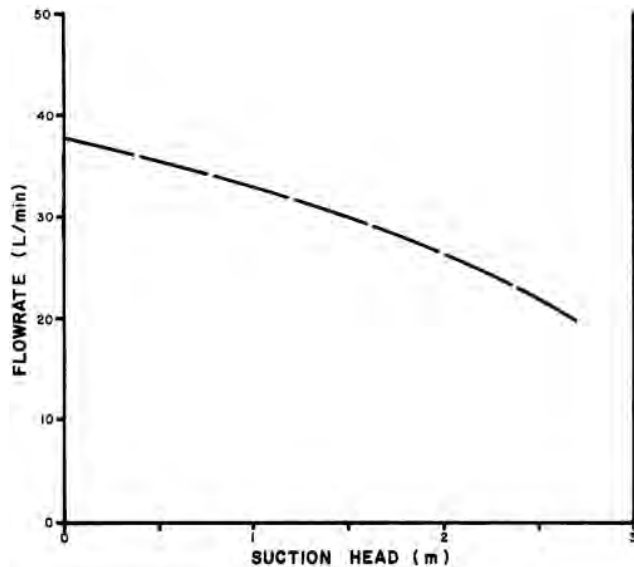

FIGURE 3. Pump Performance Characteristics with Diesel Fuel at Various Suction Heads at an Engine Intake Manifold Vacuum of 64 kPa.

**Suction Head and Tank Size:** Before fuel started flowing, the tank being filled had to be sufficiently evacuated. After opening the control valve (FIGURE 2) the vacuum increased steadily until fuel started flowing. Pump-down time depended on both suction head and tank size. At zero suction head the fuel started flowing almost immediately the control valve was opened, regardless of tank size. At a suction head of 2.7 m (9 ft), fuel began flowing after a tank vacuum of 22 kPa (3.2 psi) was reached. This took about one minute when filling a 114 L (25 gal) tank and 2.5 minutes when filling a 340 L (75 gal) tank.

Maximum flowrate was not obtained until the normal tank operating vacuum was reached. Normal operating vacuum was dependent on suction head and varied between 25 and 29 kPa (3.6 and 4.2 psi). The time required to reach the normal operating level and maximum flowrate was dependent on both suction head and tank size. FIGURE 4 shows the time required to fill various sized tanks at various suction heads when taking pump-down time into consideration. For example, considering pump-down time, it took about 8 minutes to fill a 225 L (50 gal) tank with 0.9 m (3 ft) suction head, instead of 6.9 minutes as calculated from the maximum flowrates given in FIGURE 3.

**Siphoning:** If the tank being filled was lower than the supply tank, siphoning occurred when the pump body was removed from the filled tank. A transfer line valve is available as optional equipment to prevent siphoning.

#### VACUUM REQUIREMENTS

The Vac-U-Fil pump can be operated from any engine intake manifold. Normal intake manifold vacuum at idle, for most farm trucks, ranges from 50 to 75 kPa (7.3 to 10.9 psi) with an average of about 64 kPa (9.3 psi). FIGURE 5 shows the effect of engine intake manifold vacuum on maximum flowrate at zero suction head. Flowrate decreased only slightly when the pump was operated with low intake manifold vacuums. For example, the flowrate decreased from 38 L/min (8.4 gal/min) at a typical manifold vacuum of 64 kPa (9.3 psi) to 35 L/min (7.7 gal/min) at 51 kPa (7.4 psi).

#### EASE OF OPERATION

**Fuel Tank Connection:** The Vac-U-Fil was portable and

could be quickly connected to standard tractor fuel tank openings. Optional adaptors were available for fuel tanks not having standard filler necks. The pump body was light and easy to maneuver.

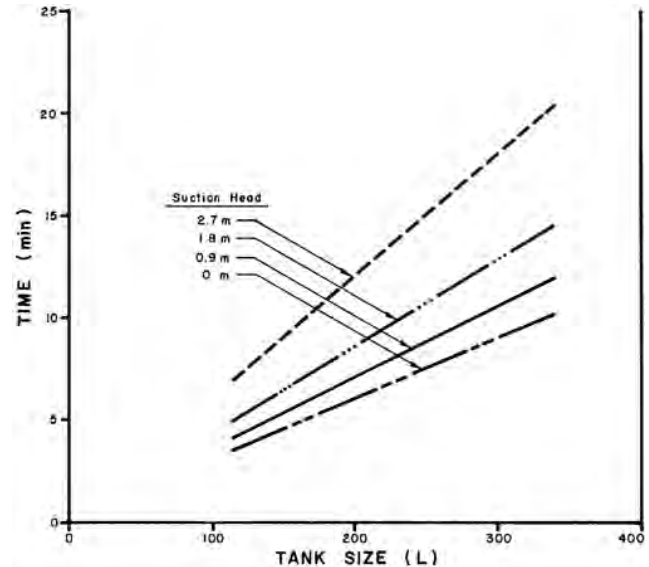

FIGURE 4. Time Required to Fill Different Sized Tanks at Various Suction Heads with Pump Operating at an Engine Intake Manifold Vacuum of 64 kPa.

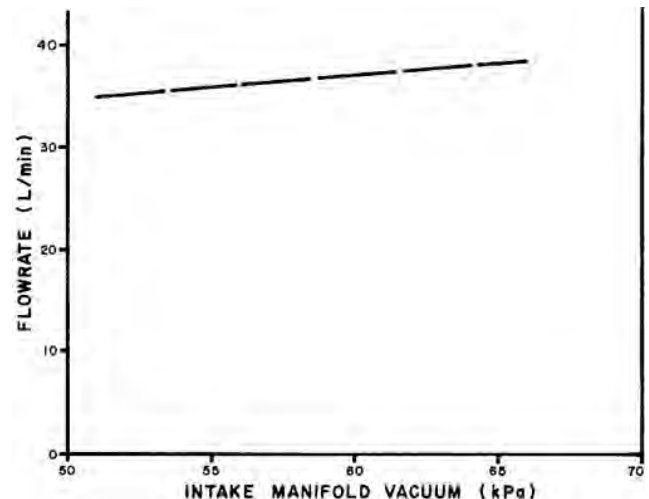

FIGURE 5. Maximum Flowrates for a Pump Operating with Different Intake Manifold Vacuums at Zero Suction Head.

The telescoping suction pipe was equipped with a 50 mm (nominal 2 inch NPT) bung adaptor to fit typical farm truck fuel supply tanks.

**Storage Adaptor:** The Vac-U-Fil pump was equipped with a storage adaptor (FIGURE 1) threaded for 50 mm (nominal 2 inch NPT) standard fuel tank openings. The pump body, when not in use, could be conveniently stored in this adaptor. Most fuel supply tanks are equipped with two openings. The suction pipe is screwed into one opening while the storage adaptor is screwed into the other. Since most supply tanks have two opening sizes, both 50 and 65 mm (nominal 2 and 2.5 inch NPT), a 65 mm (nominal 2.5 inch NPT) adaptor was usually needed before both the suction pipe and storage adaptor could be attached. It is recommended that the manufacturer supply a 65 mm (nominal 2.5 inch NPT) suction pipe bung adaptor, as standard equipment, to eliminate this problem.

**Manifold Vacuum Adaptor:** The manifold vacuum adaptor consisted of a 90° plastic elbow and a galvanized steel reducer bushing which fit most engine intake manifolds. Most new truck engines are now equipped with multiple outlets from the intake manifold. The vacuum hose supplied with the Vac-U-Fil could be connected directly to one of these outlets.

**Filling A Tank:** Once the pump body was connected to the tractor fuel tank and the truck engine started, fuel flow could be conveniently controlled with the control valve (FIGURE 2). The tank

being filled had to be air-tight and the pump body gasket properly sealed to the filler neck, before lank vacuum could be developed. Vents on vented fuel tanks had to be plugged while pumping.

The pump shut off automatically when the fuel tank was full which was convenient since it freed the operator to do other servicing while refueling. The pump body was equipped with a small window, enabling the operator to see if fuel was flowing.

**Automatic Shut-off:** The Vac-U-Fil pump was equipped with a float valve (FIGURE 2) to prevent fuel tank over filling. When the tank was full, the float valve blocked the engine manifold vacuum. The partial vacuum in the tank rapidly depleted, stopping the fuel flow. The operator was warned that the tank was full by the sound of the relief valve. At the beginning of the test, the float valve sometimes did not completely close, causing some fuel to be drawn into the engine intake manifold. This problem corrected itself after the pump was worn in.

**Servicing:** The only maintenance required was to clean the relief valve screen (FIGURE 2). A clogged screen could result in excessive vacuum levels in the tractor fuel tank, leading to tank collapse. The screen could be serviced by unscrewing the relief valve.

## SAFETY

As cautioned by the manufacturer, the Vac-U-Fil should not be used for filling fibreglass or plastic tanks due to possible tank collapse.

Since it is necessary to run the truck engine while refueling, extreme caution should be observed to prevent possible fuel vapour ignition from engine exhaust. The Vac-U-Fil was safer than some other pumps, since vapours from the tractor fuel tank were drawn directly into the truck engine intake manifold. The vacuum hose was attached to the fuel transfer hose with a number of wire fasteners (FIGURE 6). The wire ends were very sharp and could cut the hands when handling the pump. It is recommended that the manufacturer modify the vacuum hose fasteners to eliminate possible hand cuts.

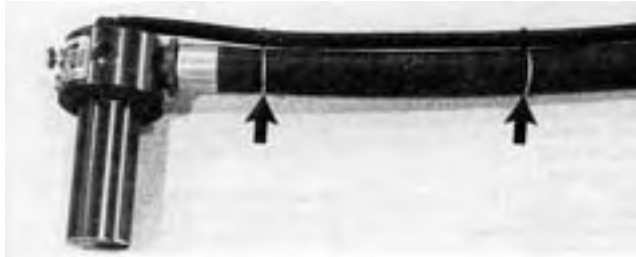

FIGURE 6. Vacuum Hose Fasteners.

## OPERATOR'S MANUAL

The instructions provided with the pump contained information on assembly, operation, servicing, solutions to possible problems and a parts list.

## MECHANICAL PROBLEMS

The Vac-U-Fil pump was operated for about 8 hours. The intent of the test was an evaluation of functional performance and an extended durability evaluation was not conducted.

A few problems occurred during the functional evaluation. The control valve knob broke (FIGURE 7) during handling. Since the pump body is constantly handled during refueling it is more prone to damage than other pumps that are permanently mounted on a fuel supply tank. It is recommended that the manufacturer consider modifications to reduce the possibility of control valve damage during handling.

The storage adaptor was fabricated from soft metal and was easily damaged when storing the pump. A burred storage adaptor caused pump gasket damage (FIGURE 8). It is recommended that the manufacturer supply a more durable storage adaptor.



FIGURE 7. Broken Control Valve Knob.



FIGURE 8. Torn Gasket.

**APPENDIX I  
SPECIFICATIONS**

<b>MAKE:</b>	Vac-U-Fil Fuel Transfer Pump
<b>POWER SOURCE:</b>	Engine Intake Manifold Vacuum
<b>DUTY CYCLE:</b>	Continuous Duty
<b>OVERALL DIMENSIONS:</b>	
-- height	128 mm (5 in)
-- body diameter	67 mm (2.6 in)
<b>TOTAL WEIGHT:</b>	5.5 kg (12 lb)
<b>SUCTION PIPE:</b>	
-- size	20 mm (nominal 0.75 inch NPT)
-- telescoping length	432 to 737 mm (17 to 29 in)
-- storage tank bung adaptor	50 mm (nominal 2 inch NPT)
<b>DISCHARGE HOSE:</b>	
-- size	20 mm (0.75 in)
-- length	5.8 m (12.3 ft)
<b>VACUUM HOSE:</b>	
-- size	6.4 mm (0.25 in)
-- length	8.1 m (26.6 ft)
<b>STORAGE ADAPTOR:</b>	
-- threaded size	50 mm (nominal 2 inch NPT)
-- standard filler neck opening	39 mm (1.5 in)
<b>MANIFOLD ADAPTOR:</b>	
-- reducer bushing	9.5 to 3.2 mm (nominal 0.375 to 0.125 inch NPT)
-- 90° outlet elbow	3.2 to 6.4 mm (nominal 0.125 to 0.25 inch NPT hose barb)

**APPENDIX II  
METRIC UNITS**

In keeping with the Canadian metric conversion program, this report has been prepared in SI units. For comparative purposes, the following conversions may be used:

1 litre per minute (L/min)	= 0.22 Imperial gallons per minute (gal/min)
1 metre (m) = 1000 millimetres (mm)	= 39.37 inches (in)
1 kilogram (kg)	= 2.20 pounds mass (lb)
1 kilopascal (kPa)	= 0.145 pounds per square inch (psi)



3000 College Drive South  
Lethbridge, Alberta, Canada T1K 1L6  
Telephone: (403) 329-1212  
FAX: (403) 329-5562  
<http://www.agric.gov.ab.ca/navigation/engineering/afmrc/index.html>

**Prairie Agricultural Machinery Institute**

Head Office: P.O. Box 1900, Humboldt, Saskatchewan, Canada S0K 2A0  
Telephone: (306) 682-2555

Test Stations:  
P.O. Box 1060  
Portage la Prairie, Manitoba, Canada R1N 3C5  
Telephone: (204) 239-5445  
Fax: (204) 239-7124

P.O. Box 1150  
Humboldt, Saskatchewan, Canada S0K 2A0  
Telephone: (306) 682-5033  
Fax: (306) 682-5080